



CITY OF CHICAGO
Department of Transportation

Field Manual for Sign Installation

OCTOBER 2021



FOREWORD

This “Field Manual” will be used by Field Service Specialists and sign hangers. It contains recommendations for the sign styles and the physical installation of signs. Consultants should refer to the “Sign Guidelines” section for sign codes and details. The intent is to institutionalize the guiding principles of the “Chicago Style” sign installation. It must be pointed out that not every scenario and problem can be anticipated; therefore, this document will be reviewed and, if necessary, revised as needed.

This manual is not meant to be all-encompassing and instead is meant to be used in conjunction with the Federal Highway Administration’s [*Manual on Uniform Traffic Control Devices*](#) (MUTCD) and other Chicago Department of Transportation (CDOT) standards found in the following documents:

- CDOT Traffic Tools and Policy
- CDOT Rules and Regulations for Construction in the Public Way

Please contact the CDOT Sign Shop or CDOT Project Development for the latest standards.

SCOPE

The list of signs (in the “Sign Guidelines” section) is to be used as a guide in selecting and ordering signs. CDOT Sign Shop will maintain an inventory of these signs in stock at all times. It is not the intent of this list to cover all signs used by the Sign Shop; it only lists those signs used in sufficient quantity to necessitate standardization and stockpiling. In cases where the list does not show an appropriate sign for a special sign project (primarily information signs), the requestor may order a special sign subject to the review and approval of the City Traffic Engineer.

MUTCD FOOTNOTE: These guidelines are not intended to conflict in any way with either the USDOT Manual of Uniform Traffic Control Devices (MUTCD) or the IDOT Standard Highway Manual. In the event of any present or future conflict, the information provided in the MUTCD or IDOT Signs Manual takes precedence.



CONTENTS

FOREWORD i

SCOPE i

CONTENTS..... ii

INTRODUCTION 1

BASIC TRAFFIC CONTROL CONCEPTS 2

REGULATORY AUTHORITIES 3

FIELD SERVICE SPECIALISTS 4

SIGN HANGERS 5

SIGN GUIDELINES SAMPLE PAGE 6

1 SIGN CLASSIFICATION 6

1.1 Sign Series 6

1.1.1 Additional signs in the series (Regulatory Number) 6

1 REGULATORY TRAFFIC CONTROL SIGNS 7

 1.1 Right of Way Series 7

 1.1.1 Stop (R1-1)..... 7

 1.1.2 Yield (R1-2) 9

 1.2 Speed Series (R2) 11

 1.3 Movement Series 13

 1.3.1 Turning (R3) 13

 1.3.2 Alignment (R4) 16

 1.3.3 Exclusion (R5, R11)..... 17

 1.3.4 One Way (R6) 19

 1.3.5 Pedestrian Series (R9) 21

 1.3.6 Traffic Signal Control Series (R10) 22

2 REGULATORY PARKING SIGNS 24

 2.1 No Parking Series 24

 2.1.1 No Parking (At All Times) and No Stopping/No Standing (R7)..... 24

 2.1.2 Specified Hours (R7) 26

 2.1.3 Specified Events (R7) 28

 2.2 Time Limit Parking Series (R7) 30

 2.3 Permit Parking Series (R7) 32

 2.4 Loading Zone Series (R7) 34

MUTCD FOOTNOTE: These guidelines are not intended to conflict in any way with either the USDOT Manual of Uniform Traffic Control Devices (MUTCD) or the IDOT Standard Highway Manual. In the event of any present or future conflict, the information provided in the MUTCD or IDOT Signs Manual takes precedence.



2.5 Bus & Taxi Zone Series (R7)..... 37

2.6 Accessible Parking Series (R7)..... 40

2.7 Angled Parking Control Series (R7) 42

2.8 School Zones Series (R7)..... 44

2.9 Snow Route Series (R7)..... 46

2.10 Street Cleaning Series (R7)..... 48

3 WARNING SIGNS 50

3.1 School Zones Series (S1) 50

3.2 Horizontal Alignment Series (W1) 52

3.3 Advance Warning Series (W3) 54

3.4 Converging Traffic Series (W4,W6)..... 56

3.5 Road Conditions Series (W8)..... 57

3.6 Crossing And Entry Signs Series (W10, W11) 58

3.7 Entrances Series (W11)..... 60

3.8 Vertical Clearance (W12)..... 61

3.9 Supplemental Speed Series (W13)..... 63

3.10 Road Cross-Section Series (W14)..... 64

3.11 Traffic Calming Series 65

4 GUIDE SIGNS 67

4.1 Street Name Signs Series (D3)..... 67

4.2 Parking Series (D4) 69

4.3 General Service Series (D9)..... 70

4.4 Bicycling Series..... 72

4.5 Transportation Series..... 75

4.6 Non-traffic Sign Series..... 76

5 Pay to Park (LAZ) signs 78

6 Commonly Used Signs: Fabrication Details 79

SUMMARY OF SIGN CLASSIFICATION 80

SIGN GUIDELINES GLOSSARY 84

List of Exhibits

- Sign Post Mounting and Installation Details
- Dig – Sign Post Mounting and Installation Details
- Drill – Sign Post Mounting and Installation Details

MUTCD FOOTNOTE: These guidelines are not intended to conflict in any way with either the USDOT Manual of Uniform Traffic Control Devices (MUTCD) or the IDOT Standard Highway Manual. In the event of any present or future conflict, the information provided in the MUTCD or IDOT Signs Manual takes precedence.



Sign Layout Installation

D3-1 Street Name Sign Installation

Regulatory Sign Installation on Traffic Signals

D3-1 Sign and Bracket Specs

CDOT Street Name Sign Standard – 7/16/2019

CDOT Corner Clearance Detail

Commonly Used Sign Blank Details

- 30” Octagon Stop Sign
- 36” Octagon Oversized Stop Sign
- 30x30” Do Not Enter Sign
- 18”X24” One Way Arrow R6-2L
- 18”X24” One Way Arrow R6-2R
- 30” Pentagon School Advance Sign
- 18”x18” No Parking Tow Zone Sign
- 18”x18” Bus Stop with Arrow Sign
- 36” Pentagon School Advance Sign
- 24”x30” One Way Arrow Sign



INTRODUCTION

The *Field Manual for Sign Installation* (also referred to as the “Manual”) was developed by the Chicago Department of Transportation (CDOT), to be used when ordering and hanging signs. Signs provide essential information for vehicles and pedestrians; therefore, a consistent, uniform message in public signing is necessary to ensure safe and orderly movement of all traffic. Excessive signage in one location creates visual clutter, and vital traffic information can be lost. This Manual addresses those concerns, it contains practical, easy to understand guidelines for ordering and hanging signs.

Purpose and Goals

- Develop the “Chicago Style” sign system (see below).
- Achieve consistency in sign installation.
- Develop signage standards that communicate information clearly to all vehicles and pedestrians.
- Eliminate obsolete, excessive, confusing, and/or redundant signs.

Chicago Style

The “Chicago Style” of sign installation is currently used primarily for parking signs. New materials and mounting methods produce a design that meets federal, state, and local requirements and functions without being visually obtrusive. The guiding principles include:

- Standardization of most parking signs to 18-inch-by-18-inch size.
- Black painted poles and bases.
- Two signs per pole.
- Use of symbols instead of actual verbiage on signs (when possible).
- Two signs per block face (parking signs).
- Installation of signs on light poles and sign posts between 10’-7” and 7’-0” from top of sidewalk to the bottom of the sign (when possible).
- Due to the importance of traffic signs at intersections, a limited number of traffic-related and guide signs are allowed on traffic signals and light poles (at intersections).

Document Features

This document contains the following features:

- Guidelines for consistent sign ordering and installation.
- Practical, easy to understand information.
- Description of the “Chicago Style” sign system.

This document is a 2021 update to the original Sign Guidelines.



BASIC TRAFFIC CONTROL CONCEPTS

Purpose of Traffic Control Devices

Traffic control devices are all signs, signals, markings, and devices placed on, over, or adjacent to the public way; they facilitate traffic movement and ensure a safe roadway. According to the MUTCD, their purpose is the following:

“Traffic control devices, as well as the principles for their use, is to promote highway safety and efficiency by providing for the orderly movement of all road users on streets, highways, bikeways, and private roads open to public travel throughout the Nation.” (1A-1)

Function of Signs

This Manual is designed to address the effective placement of signs; when not properly installed, their value and function is significantly diminished. The MUTCD states that to be effective, traffic control devices should meet the following five basic requirements:

- *Fulfill a need*
- *Command attention*
- *Convey a clear, simple meaning*
- *Command respect of road users*
- *Give adequate time for proper response (1A-2)*

Excessive Use of Signs

Excessive signage in one location creates visual clutter, and vital traffic information can be lost. The MUTCD states the following:

“Regulatory and warning signs should be used conservatively because these signs, if used to excess, tend to lose their effectiveness. If used, route signs and directional guide signs should be used frequently because their use promotes efficient operations by keeping road users informed of their location.” (2A-4)

Engineering Judgment

Sign placement is based on standard statements within the MUTCD; however, Guidance statements allow for deviations if engineering judgment or engineering study indicates appropriate. According to the MUTCD:

“Standard statements shall not be modified or compromised based on engineering judgment or engineering study.” (1A-13)

“Guidance – a statement of recommended, but not mandatory, practice in typical situations, with deviations allowed if engineering judgment or engineering study indicates the deviation to be appropriate.” (1A-13)

Warranted Conditions

In determining the need for a sign, it is useful to examine the MUTCD’s description of the function of a sign:

“This Manual contains Standards, Guidance, and Options for the signing of all types of highways, and private roads open to public travel. The functions of signs are to provide regulations, warnings, and guidance information for road users. Words, symbols, and arrows are used to convey the messages. Signs are not typically used to confirm rules of the road.” (2A-1)

MUTCD FOOTNOTE: These guidelines are not intended to conflict in any way with either the USDOT Manual of Uniform Traffic Control Devices (MUTCD) or the IDOT Standard Highway Manual. In the event of any present or future conflict, the information provided in the MUTCD or IDOT Signs Manual takes precedence.



REGULATORY AUTHORITIES

“Traffic control devices, advertisements, announcements, and other signs or messages within the highway right-of-way shall be placed only as authorized by a public authority or the official having jurisdiction, or, in the case of private roads open to public travel, by the private owner or private official having jurisdiction, for the purpose of regulating, warning, or guiding traffic.” (MUTCD 1A-8)

In the City of Chicago, the City Council (the public body) and the Department of Transportation (the City agency) are responsible for ensuring the safe movement for all traffic on the public way. In addition, there are state and federal underlying authorities that mandate standards for sign installation. The following subsections briefly description each.

Manual on Uniform Traffic Control Devices (MUTCD)

The MUTCD provides national uniform standards for the design and placement of all traffic control devices, including, but not limited to, signs and pavement markings. It provides required, recommended, and permitted conditions to be used in the design and installation of signs. The MUTCD has been adopted by the Illinois Department of Transportation as the standard to be used when providing signs within the City. This manual is not meant to be all-encompassing of the MUTCD but rather lists commonly used signs and “Chicago Style” signs.

State Authority (Illinois Compiled Statutes)

Section 5/11 of the Illinois Vehicle Code generally empowers local authorities to regulate traffic within their jurisdictions. However, such powers are limited by the Vehicle Code provision, which restricts home rule authority to the extent that municipalities may not adopt provisions inconsistent with the State requirements. Furthermore, with respect to signage, traffic signs must conform to the standards invoked by the MUTCD.

Illinois Supplement to the Manual on Uniform Traffic Control Devices

The Federal manual is adopted as the official manual for a uniform system of traffic control devices for the State of Illinois subject to the amendments as set forth in the Illinois Supplement to the National Manual on Uniform Traffic Control Devices to address unique state laws and policies. All Illinois Standard signs which differ from those in the MUTCD will have a letter and number designation beginning with the letter “I”. Please refer to the Illinois Supplement to the MUTCD for additional information.

Municipal Code of Chicago

City Council Authority – Many traffic control proposals are initiated by aldermanic request and are evaluated and implemented by CDOT’s technical staff. Traffic control initiatives that require City Council approval are referred to the Committee on Pedestrian & Traffic Safety. The committee shall have jurisdiction over ordinances and matters relating to vehicular and pedestrian traffic. The necessity of City Council approval is one of the informational items described in the Manual. The Department maintains a close working relationship with the Chairman and staff of the Committee on Pedestrian & Traffic Safety on both technical and legislative levels. In addition, CDOT recognizes the benefit of these aldermanic proposals for traffic control improvements and values aldermanic contributions and insights into specific ward traffic conditions.

Commissioner Powers under the Municipal Code of Chicago – Title 9 of the Municipal Code of Chicago invests the Commissioner of Transportation with broad traffic management powers. Under the provisions of Section 9-8-010 of the Municipal Code, the Commissioner of Transportation is authorized to cause the placement, erection, and maintenance of traffic control devices. As a result, a wide variety of traffic control improvement activities of the Department of Transportation are initiated and implemented by the Department’s technical staff.

MUTCD FOOTNOTE: These guidelines are not intended to conflict in any way with either the USDOT Manual of Uniform Traffic Control Devices (MUTCD) or the IDOT Standard Highway Manual. In the event of any present or future conflict, the information provided in the MUTCD or IDOT Signs Manual takes precedence.



FIELD SERVICE SPECIALISTS

Field Service Specialists (II, III, and Supervisors) and Engineering Technicians (III, IV, V, and VI) must follow this Manual when writing work orders. The “General Guidelines” and “Standard Applications” sections contain valuable information on the correct placement and the proper relationships between signs. Sign clutter occurs when too many signs are installed in one area; it is confusing and not aesthetically pleasing. Sign clutter can be prevented by ordering the correct type, number, and placement of signs. Listed below are some general rules to follow when ordering signs.

RULES FOR FIELD SERVICE SPECIALISTS

1. Order signs for light poles first, before ordering a new sign pole (when exact location is not critical).
2. Never order signs for ornamental poles.
3. Never order more than two signs for drill and dig poles.
4. Do not order traffic, warning, and parking signs for the same pole.
5. Order the repair of crooked or dangling signs and replacement of damaged, faded, or old signs in the block or the area where you are working.
6. Do not order Chicago style signs (18” x 18”) on the same pole with old sign type (12” x 18”). (Replace old sign type (12” x 18”) when ordering new signs).
7. Keep similar signs of same type at consistent height.
8. Review and remove contradictory messages, especially parking signs. Avoid unnecessary redundancy.
9. Order signs to be installed from top down within installation-zone specifications of 10’-7” and 7’ 0” from top of sidewalk to the bottom of the sign (when possible).
10. Due to the importance of traffic signs at intersections, a limited number of traffic-related and guide signs are allowed on traffic signals and light poles (at intersections).

Note: For Dig installations, the contractor needs to follow CDOT’s excavation policy and procedures as noted in the [2019 CDOT Rules and Regulation for Construction in the Public Way](#).



SIGN HANGERS

Before installing a sign, the sign hanger must determine if the work order follows basic sign guidelines. If there are any questions about placement, they can quickly reference this Manual to avoid mistakes; it contains detailed instructions for sign installation. Note that occasionally there may be exceptions to these guidelines. This manual is a convenient reference for proper installation of signs and should not be used to second guess every work order. If a problem exists, a supervisor must be called. Listed below are general rules when hanging signs.

RULES FOR SIGN HANGERS

1. Hang signs on light poles first, before installing a new pole (when exact location is not critical).
2. Never hang signs on ornamental poles.
3. Never hang more than two signs on drill and dig poles.
4. Hang traffic, warning, and parking signs on separate poles.
5. Fix crooked or dangling signs immediately (in the block or area where you are working), and report damaged and missing signs to your supervisor.
6. Do not hang Chicago style signs (18" x 18") on the same pole with old sign type (12" x 18").
7. When installing signs, keep multiple signs of the same type at consistent height.
8. You must call your supervisor before installing signage if your current work order creates a contradictory message and/or unnecessary redundancy.
9. Install signs from top down within installation-zone specifications of 10'-7" at top and 7'-0" from top of sidewalk to the bottom of the sign (when possible).
10. Due to the importance of traffic signs at intersections, a limited number of traffic-related and guide signs are allowed on traffic signals and light poles (at intersections).
11. Drill and dig poles must be vertical (use level to check at shim bases and sloped locations), and signs must be installed straight on pole.
12. Use two bands for a typical flag-mounted sign.
13. Do not overlap signs; use two bolts.
14. Remove and recycle all old and unused bands on pole.
15. Always wear your safety vest.
16. When in doubt, call your supervisor

Note: For Dig installations, the contractor needs to follow CDOT's excavation policy and procedures as noted in the [2019 CDOT Rules and Regulation for Construction in the Public Way](#).

MUTCD FOOTNOTE: These guidelines are not intended to conflict in any way with either the USDOT Manual of Uniform Traffic Control Devices (MUTCD) or the IDOT Standard Highway Manual. In the event of any present or future conflict, the information provided in the MUTCD or IDOT Signs Manual takes precedence.



SIGN GUIDELINES SAMPLE PAGE

The guideline section of this manual is broken down by sign classification, series, and group. Each page contains the following information: sign specification, general guidelines, standard applications, and applicable references to various regulating authorities. Below is a sample page of the guidelines section. Please refer to *Summary of Sign Classification* and *Sign Guidelines Glossary* for additional details.

1 SIGN CLASSIFICATION

1.1 Sign Series

1.1.1 Additional signs in the series (Regulatory Number)

Signs	Code	Size	Shape	Colors
<i>Text or symbols on sign</i>	<i>Sign code</i>	<i>Sign Size</i>	<i>Shape of sign</i>	<i>Colors on sign</i>

Sign images are only provided for CDOT-style signs. Please refer to the MUTCD for other sign images.

GENERAL GUIDELINES

This section includes guidelines for sign ordering and installation.

STANDARD APPLICATIONS

Location:	<i>Location for a sign (within the block).</i>
Distance from property line (0+00):	<i>Measurement for recommended location of a sign.</i>
Number of Signs per Block:	<i>Maximum number of an individual sign per block.</i>
Types of poles:	<i>The type of pole on which a sign is installed.</i>
Mounting height:	<i>The height that a sign must be mounted.</i>
Mounting:	<i>Methods used to mount a sign to a pole.</i>
Angle:	<i>The angle (between a sign and the curb line) in which a sign is mounted.</i>
Sign Blank:	<i>Indicates if the message is printed on one or both sides of a sign.</i>
Co-Mounting:	<i>Identifies signs that can be installed on the same pole.</i>
Exception:	<i>Lists any exception for a sign.</i>
Notes:	<i>Provides additional information.</i>

MUTCD

Applicable sections are referenced.

ILLINOIS COMPLIED STATUTES

Applicable sections are referenced, also states if an ordinance is required or not.

MUNICIPAL CODE OF CHICAGO

Applicable sections are referenced.

MUTCD FOOTNOTE:

This MUTCD footnote is included on every page.

ORDINANCE REQUIREMENTS

This indicates whether an ordinance is required for certain signs.

MUTCD FOOTNOTE: These guidelines are not intended to conflict in any way with either the USDOT Manual of Uniform Traffic Control Devices (MUTCD) or the IDOT Standard Highway Manual. In the event of any present or future conflict, the information provided in the MUTCD or IDOT Signs Manual takes precedence.



1 REGULATORY TRAFFIC CONTROL SIGNS

1.1 Right of Way Series

1.1.1 Stop (R1-1)

Signs	Code	Size	Shape	Colors
1. Stop	R1-1	30 x 30	Octagon	W/R
2. Stop (oversized)	R1-1-2	36 x 36	Octagon	W/R
3. All Way	R1-3P	6 x 18	Rectangle	W/R
4. Cross Traffic Does Not Stop	W4-4P	24 x 12	Rectangle	B/Y
5. Traffic from Left Does Not Stop	W4-4APL	24 x 12	Rectangle	B/Y
6. Traffic from Right Does Not Stop	W4-4APR	24 x 12	Rectangle	B/Y
7. Oncoming Traffic Does Not Stop	W4-4BP	24 x 12	Rectangle	B/Y

GENERAL GUIDELINES

1. Signs should always be installed on near right approach.
2. On two way arterial streets, near right and far left signs mounted back to back are used on the arterial approach.
3. Install signs near-right and near-left on one way streets over thirty feet wide.
4. No signs other than One Way, Do Not Enter or Street Name Signs should be installed on same pole as Stop signs.
5. 36"x36" signs are only used on high-volume arterial streets.
6. Do not install within 4 feet of a fire hydrant.
7. Refer to Commonly Used Signs: Fabrication Detail for R1-1 and R1-1-2.

STANDARD APPLICATIONS

Location:	intersection at stop bar or at least 4 ft. before crosswalk
Distance from Property Line (0+00):	4 ft. upstream of property line typical
Number of signs per Block Face:	1. One Way Street - 1 sign 2. Two Way Street - 2 signs
Types of Poles:	light pole, drill, dig
Mounting Height:	7'-0" clearance to bottom of sign
Mounting:	center, back-to-back
Angle:	90 degrees (where two roads intersect at an acute angle, the Stop or Yield signs should be positioned at an angle or shielded so that the legend is out of view of traffic to which it does not apply. MUTCD 2B-06)

MUTCD FOOTNOTE: These guidelines are not intended to conflict in any way with either the USDOT Manual of Uniform Traffic Control Devices (MUTCD) or the IDOT Standard Highway Manual. In the event of any present or future conflict, the information provided in the MUTCD or IDOT Signs Manual takes precedence.



STANDARD APPLICATIONS

Sign Blank:	single-sided
Co-Mounting:	Do Not Enter signs may be installed back to back with Stop signs. Center mounted One Way or Street Name
Exception:	Stop signs may be installed mid-block at crosswalk
Note:	Does not apply

MUTCD

Part 2B: Regulatory Signs, Barricades, and Gates
Section 2B-05: Stop Sign and All Way Plaque
Part 2C: Warning Signs and Object Markers
Section 2C-59: Cross Traffic Does Not Stop Plaque

ILLINOIS COMPILED STATUTES

Illinois Vehicle Code: (625 ILCS 5)
Section: 11-208 (a) 2, 6: Powers of Local Authorities

MUNICIPAL CODE OF CHICAGO

Chapter 9-24: Right of Way
Section 9-24-010: Stop signs

ORDINANCE REQUIREMENTS

Yes. Department policy requires that an ordinance be passed by City Council for installation of Stop signs on through streets. New installation should be based on work order with ordinance date and page.

MUTCD FOOTNOTE: These guidelines are not intended to conflict in any way with either the USDOT Manual of Uniform Traffic Control Devices (MUTCD) or the IDOT Standard Highway Manual. In the event of any present or future conflict, the information provided in the MUTCD or IDOT Signs Manual takes precedence.



1.1.2 Yield (R1-2)

Signs	Code	Size	Shape	Colors
1. Yield (Symbol)	R1-2-1	30 x 30 x 30	Triangle	R/W
2. Turning Traffic Must Yield to Pedestrians	R10-15 Special	24 x 30	Rectangle	B/W
3. Turning Vehicles Yield to Pedestrians (Symb)	R10-15 (L/R)	30 x 30	Rectangle	B/W/Y, R/W
4. Turning Vehicles Yield to Bikes (Symb)	R10-15 (L/R) Special	30 x 30	Rectangle	B/W/Y, R/W
5. Turning Vehicles Yield to Bike/Pedestrians (Symb)	R10-15 (L/R) Special	30 x 30	Rectangle	B/W/Y, R/W
6. Turning Vehicles Stop for Pedestrians (Symb)	R10-15A (L/R)	30 x 30	Rectangle	B/W/Y, R/W
7. Turning Vehicles Stop for Bikes/Pedestrians (Symb)	R10-15A (L/R) Special	30 x 30	Rectangle	B/W/Y, R/W



R10-15 Special



R10-15



R10-15R Special



R10-15L Special



R10-15AR



R10-15AR Special

GENERAL GUIDELINES

1. Installation and location of signs should be based on engineering and traffic studies by the Department of Transportation. A City Traffic Engineer must provide authorization prior to installation of new signs.

STANDARD APPLICATIONS

Location:	as specified by CDOT engineering study
Distance from Property Line (0+00):	as specified in CDOT engineering study
Number of signs per Block Face:	1
Types of Poles:	light pole, drill, dig
Mounting Height:	7'-0" clearance to bottom of sign

MUTCD FOOTNOTE: These guidelines are not intended to conflict in any way with either the USDOT Manual of Uniform Traffic Control Devices (MUTCD) or the IDOT Standard Highway Manual. In the event of any present or future conflict, the information provided in the MUTCD or IDOT Signs Manual takes precedence.



Mounting:	center
Angle:	90 degrees
Sign Blank:	single-sided
Co-Mounting:	Do Not Enter sign may be installed back-to-back with Yield sign.
Exception:	Does not apply
Note:	N/A

MUTCD

Part 2B: Regulatory Signs, Barricades, and Gates

Section 2B-08: Yield Sign

Section 2B-53: Traffic Signal Signs

ILLINOIS COMPILED STATUTES

Illinois Vehicle Code: (625 ILCS 5)

Section: 11-208 (a) 6,8: Powers of Local Authorities

MUNICIPAL CODE OF CHICAGO

Chapter 9-24: Right of Way

Section 9-24-070: Yield Right of Way signs

ORDINANCE REQUIREMENTS

No. Ordinance not required.

MUTCD FOOTNOTE: These guidelines are not intended to conflict in any way with either the USDOT Manual of Uniform Traffic Control Devices (MUTCD) or the IDOT Standard Highway Manual. In the event of any present or future conflict, the information provided in the MUTCD or IDOT Signs Manual takes precedence.



1.2 Speed Series (R2)

Signs	Code	Size	Shape	Colors
1. Speed Limit 20	R2-1-0A	24 x 30	Rectangle	B/W
2. Speed Limit 25	R2-1-1	24 x 30	Rectangle	B/W
3. Speed Limit 30	R2-1-2	24 x 30	Rectangle	B/W
4. Speed Limit 35	R2-1-3	24 x 30	Rectangle	B/W
5. Speed Limit 40	R2-1-4	36 x 48	Rectangle	B/W
6. Speed Limit 45	R2-1-5	36 x 48	Rectangle	B/W

GENERAL GUIDELINES:

1. Citywide speed limit is: 30 mph on streets unless modified by ordinance and determined based on an engineering or traffic study.
2. Citywide speed limit is: 15 mph in alleys. However, alley speed limits are not to be posted.
3. Install signs at beginning of first block approximately 100' on the far side of the intersection, or mid-block, where there is a speed limit change.
4. When installing 30 mph speed signs, provide minimum of one-mile intervals between signs.
5. When installing speed limit signs other than 30 mph, provide minimum of 1/4 mile between signs.
6. State Law and City Code prohibit establishment of Speed Limits below 20 mph on streets.

STANDARD APPLICATIONS:

Location:	mid-block
Distance from Property Line (0+00):	100 ft.
Number of signs per Block Face:	1
Types of Poles:	light pole, dig, drill
Mounting Height:	7'-0" clearance to bottom of sign
Mounting:	center
Angle:	90 degrees
Sign Blank:	single-sided
Co-Mounting:	May be mounted with Regulatory Traffic signs
Exception:	Does not apply
Note:	For school Speed Limit signs, see Section 3.1. School Zone Series. Distance of Speed Limit sign from property line may be adjusted to allow installation of sign on light pole.

MUTCD

Part 2B: Regulatory Signs, Barricades, and Gates
 Section 2B-13: Speed Limit Sign

MUTCD FOOTNOTE: These guidelines are not intended to conflict in any way with either the USDOT Manual of Uniform Traffic Control Devices (MUTCD) or the IDOT Standard Highway Manual. In the event of any present or future conflict, the information provided in the MUTCD or IDOT Signs Manual takes precedence.



ILLINOIS COMPILED STATUTES

Illinois Vehicle Code: (625 ILCS 5)

Section 11-208(a) 10: Powers of Local Authority

Section 11-601: Speed restrictions

Section 11-604: Alteration of Limits by Local Authorities

MUNICIPAL CODE OF CHICAGO:

Chapter 9-12: Traffic and Speed Restrictions

Section 9-12-070: Speed Limits

Chapter 9-8: Traffic Control Devices and Signals

Section 9-8-010: Authorized – Compliance required.

ORDINANCE REQUIREMENTS

Yes. Ordinance is required through city council to alter speed limits.

MUTCD FOOTNOTE: These guidelines are not intended to conflict in any way with either the USDOT Manual of Uniform Traffic Control Devices (MUTCD) or the IDOT Standard Highway Manual. In the event of any present or future conflict, the information provided in the MUTCD or IDOT Signs Manual takes precedence.



1.3 Movement Series

1.3.1 Turning (R3)

Signs	Code	Size	Shape	Colors
1. No Right Turn (Symbol)	R3-1-1	24 x 24	Rectangle	R-B/W
2. No Right Turn (Symbol)(Time)-Day	R3-1G	24 x 36	Rectangle	R-B/W
3. No Right Turn (Symbol)(Time)(Time)-(Day)	R3-1H	24 x 42	Rectangle	R-B/W
4. No Right Turn (Symbol) Except Buses	R3-1E	24x 36	Rectangle	R-B/W
5. No Left Turn (Symbol)	R3-2-1	24 x 24	Rectangle	R-B/W
6. No Left Turn (Symbol)(Time)-(Day)	R3-2G	24 x 36	Rectangle	R-B/W
7. No Left Turn (Symbol)(Time)-(Time)-(Day)	R3-2H	24 x 42	Rectangle	R-B/W
8. No Turns	R3-3-1	24 x 24	Rectangle	B/W
9. No U Turn (Symbol)	R3-4-1	24 x 24	Rectangle	R-B/W
10. U Turn Permitted	R3-4-2	18 x 24	Rectangle	B/W
11. Left Turn Only (Symbol)	R3-5L	30 x 36	Rectangle	B/W
12. Right Turn Only (Symbol)	R3-5R	30 x 36	Rectangle	B/W
13. Right (Left) Lane Must Turn Right (Left)	R3-7R/L	30 x 30	Rectangle	B/W
14. Double Arrow Left and Straight (Symbol)	R3-6L	30 x 30	Rectangle	B/W
15. Double Arrow Right and Straight (Symbol)	R3-6R	30 x 30	Rectangle	B/W
16. Left Arrow Only; Double Arrow Left & Straight (Symbol)	R3-8L	30 x 30	Rectangle	B/W
17. Right Arrow Only; Double Arrow Right & Straight (Symbol)	R3-8R	30 x 30	Rectangle	B/W
18. Left Arrow Only, Straight Arrow Only, Right Arrow Only	R3-8B	Variable x 30	Rectangle	B/W

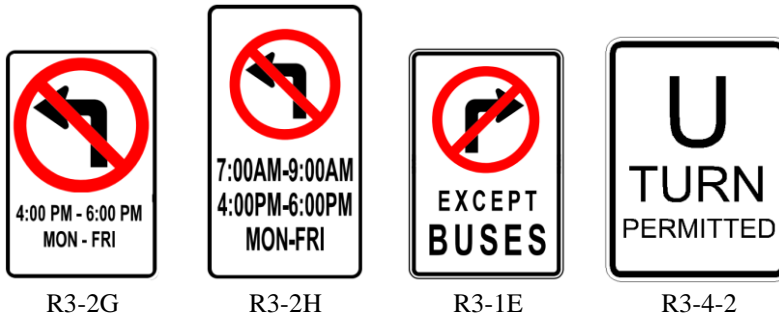

GENERAL GUIDELINES

1. Installation and location of signs should be based on CDOT engineering and traffic study. Authorization by a Field
2. Service Supervisor required prior to installation of new signs.

MUTCD FOOTNOTE: These guidelines are not intended to conflict in any way with either the USDOT Manual of Uniform Traffic Control Devices (MUTCD) or the IDOT Standard Highway Manual. In the event of any present or future conflict, the information provided in the MUTCD or IDOT Signs Manual takes precedence.



3. Location of signs on signal mast arm should be based on typical layout shown in exhibit *Regulatory Sign Installation on Traffic Signals*. Turn prohibition signs (#1 & #5) may should be used to supplement One Way signs at signalized intersections, high speed intersections, and intersection of two arterials.
4. At one-way alleys and commercial/industrial parking lot exits, signs may be posted mid-block.
5. See Section 4.4, Bicycling, for special versions of Intersection Lane Control Signs with exceptions for bicycles and buses.

STANDARD APPLICATIONS

Location:	intersection, mid-block (No U Turn sign)
Distance from Property Line (0+00):	based on CDOT engineering study
Number of signs per Block Face:	varies
Types of Poles:	dig, drill, light pole, traffic signal pole, mast arm
Mounting Height:	7'-0" clearance to bottom of sign for dig, drill, light pole mounts; 6 inches above signal head on traffic signal pole; center on
Mounting:	center
Angle:	90 degrees
Sign Blank:	single-sided
Co-Mounting:	May be mounted with other Regulatory Traffic signs.
Exception:	At One Way alleys and commercial/industrial parking lot exits, signs may be posted mid-block.
Note:	<ul style="list-style-type: none"> • Left Turn Only and Right Turn Only signs (#11 & #12) are intended for overhead use. • No Turning signs are sometimes posted at the street before a signalized intersection to prevent cut through traffic. • For R3 series Bicycle signs, (see 4.4 Bicycling Series). through traffic.

MUTCD

- Part 2B: Regulatory Signs, Barricades, and Gates
- Section 2B-18: Movement Prohibition Signs
- Section 2B-19: Intersection Lane Control Signs
- Section 2B-20: Mandatory Movement Lane Control Signs
- Section 2B-21: Optional Movement Lane Control Sign
- Section 2B-22: Advance Intersection Lane Control Signs

ILLINOIS COMPILED STATUTES

- Illinois Vehicle Code: (625 ILCS 5)
- Section 11-208(a) 9, 11: Powers of Local Authorities

MUNICIPAL CODE OF CHICAGO

- Chapter 9-16: Turning Movements
- Section 9-16-050: Turns Restricted

MUTCD FOOTNOTE: These guidelines are not intended to conflict in any way with either the USDOT Manual of Uniform Traffic Control Devices (MUTCD) or the IDOT Standard Highway Manual. In the event of any present or future conflict, the information provided in the MUTCD or IDOT Signs Manual takes precedence.



ORDINANCE REQUIREMENTS

Yes. Ordinance required for Turning Restrictions during specific times and days.

MUTCD FOOTNOTE: These guidelines are not intended to conflict in any way with either the USDOT Manual of Uniform Traffic Control Devices (MUTCD) or the IDOT Standard Highway Manual. In the event of any present or future conflict, the information provided in the MUTCD or IDOT Signs Manual takes precedence.



1.3.2 Alignment (R4)

Signs	Code	Size	Shape	Colors
1. Keep Right (Symbol)	R4-7	24 x 30	Rectangle	B/W
2. Keep [Horizontal Right Arrow] Right	R4-7A	24 x 30	Rectangle	B/W
3. Keep Left (Symbol)	R4-8	24 x 30	Rectangle	B/W
4. Keep [Horizontal Left Arrow] Left	R4-8A	24 x 30	Rectangle	B/W

GENERAL GUIDELINES

1. Installation and location of signs should be based on CDOT engineering and traffic study. Authorization by a Field Service Supervisor required prior to installation of new signs.
2. Keep Right signs (#1 and #2) and Keep Left signs (#3 and #4) are interchangeable.

STANDARD APPLICATIONS

Location:	intersection, mid-block, special zone
Distance from Property Line (0+00):	As specified in CDOT engineering study.
Number of signs per Block Face:	1
Types of Poles:	light pole, dig, drill, other structures
Mounting Height:	7'-0" clearance to bottom of sign
Mounting:	center
Angle:	90 degrees
Sign Blank:	single-sided
Co-Mounting:	Signs can be mounted with other Regulatory Traffic or Warning signs
Exception:	Keep Right signs (#1, #2) and Keep Left signs (#3, #4) may be mounted on face of obstruction such as bridge of viaduct pier.
Note:	For R4 Series Bicycle signs (see 4.4 Bicycling Series).

MUTCD

Part 2B: Regulatory Signs, Barricades, and Gates
Section 2B-32: Keep Right and Keep Left Signs

ILLINOIS COMPILED STATUTES

Illinois Vehicle Code: (625 ILCS 5)
Section 11-208(a) 2: Powers of Local Authorities

MUNICIPAL CODE OF CHICAGO

Chapter 9-16: Turning Movements
Section 9-16-010: Markings and Indicating Devices

ORDINANCE REQUIREMENTS

No. Ordinance not required.

MUTCD FOOTNOTE: These guidelines are not intended to conflict in any way with either the USDOT Manual of Uniform Traffic Control Devices (MUTCD) or the IDOT Standard Highway Manual. In the event of any present or future conflict, the information provided in the MUTCD or IDOT Signs Manual takes precedence.



1.3.3 Exclusion (R5, R11)

Signs	Code	Size	Shape	Colors
1. Do Not Enter	R5-1	30 x 30	Rectangle	W/R
2. Wrong Way	R5-1A	36 x 24	Rectangle	W/R
3. No Trucks (Symbol)	R5-2-1	24 x 24	Rectangle	R-B/W
4. No Trucks (Symbol) Over 5 Tons Gross Weight	R5-2-2	24 x 24	Rectangle	R-B/W
5. Thru Traffic Prohibited	R5-2-6	18 x 24	Rectangle	B/W
6. No Bicycles (Symbol)	R5-6-1	24 x 24	Rectangle	R-B/W
7. No Bicycles (Symbol) on Sidewalk	R5-6-2	18 x 18	Rectangle	R-B/W
8. No Bicycles (Symbol) on Sidewalk W/(Age),(Fine)	R5-6-2A	18 x 24	Rectangle	R-B/W
9. Street Closed	R11-2-1	48 x 30	Rectangle	B/W
10. Street Closed Local Traffic Only	R11-3-1	60 x 30	Rectangle	B/W



GENERAL GUIDELINES

1. Do Not Enter should be used at locations where there is traffic approaching a street or alley segment which is one-way in the opposing direction or locations (e.g. exit ramps) where wrong way traffic may pose a greater potential for severe accidents.
2. Wrong Way signs are only installed on exit ramps in combination with Do Not Enter signs.
3. No Truck signs should be installed on boulevards or other streets where trucks are prohibited by ordinance. Sign should be installed far right, Station 0+00.
4. No Trucks Over 5 Tons signs are installed on local streets adjacent to arterials. Signs should be installed far right at station 0+00.
5. Refer to Commonly Used Signs: Fabrication Detail for R5-1.

STANDARD APPLICATIONS

Location:	intersections, mid-block at alleys
Distance from Property Line (0+00):	0 to 15 ft.
Number of signs per Block Face:	1; 2 (Do Not Enter)
Types of Poles:	light pole, signal pole, dig, drill
Mounting Height:	7'-0" clearance to bottom of sign
Mounting:	center

MUTCD FOOTNOTE: These guidelines are not intended to conflict in any way with either the USDOT Manual of Uniform Traffic Control Devices (MUTCD) or the IDOT Standard Highway Manual. In the event of any present or future conflict, the information provided in the MUTCD or IDOT Signs Manual takes precedence.

**STANDARD APPLICATIONS**

Angle:	90 degrees
Sign Blank:	single-sided
Co-Mounting:	Do Not Enter can be mounted with Stop, Yield, or Street Name signs.
Exception:	Street Closed Local Traffic Only signs and Street Closed signs may be mounted on barricades.
Note:	For other bicycling signs, refer to section 4.4 (Bicycling Series).

MUTCD

Part 2B: Regulatory Signs, Barricades, and Gates

Section 2B-37: Do Not Enter Sign

Section 2B-38: Wrong Way Sign

Section 2B-39: Selective Exclusion Signs

ILLINOIS COMPILED STATUTES

Illinois Vehicle Code: (625 ILCS 5)

Section 11-208(a) 2,4,8,9: Powers of Local Authorities

MUNICIPAL CODE OF CHICAGO

Chapter 9-72-030: Designation of streets with size and weight limitations

Chapter 9-8: Traffic Control Devices and Signals

Section 9-8-010: Authorized – Compliance required.

ORDINANCE REQUIREMENTS

Yes. Ordinance is required through city council for vehicle weight limitations and truck restrictions (9-72-030).

MUTCD FOOTNOTE: These guidelines are not intended to conflict in any way with either the USDOT Manual of Uniform Traffic Control Devices (MUTCD) or the IDOT Standard Highway Manual. In the event of any present or future conflict, the information provided in the MUTCD or IDOT Signs Manual takes precedence.



1.3.4 One Way (R6)

Signs	Code	Size	Shape	Colors
1. One Way Left Arrow (Symbol)	R6-2L	18 x 24	Rectangle	B/W
2. One Way Right Arrow (Symbol)	R6-2R	18 x 24	Rectangle	B/W
3. One Way Left Arrow (Symbol) Except Bikes	R6-2L Special	18 x 24	Rectangle	B/W
4. One Way Right Arrow (Symbol) Except Bikes	R6-2R Special	18 x 24	Rectangle	B/W
5. Begin One Way	R6-6	18 x 24	Rectangle	B/W



R6-2L Special

GENERAL GUIDELINES

1. New signs should be installed based on ordinance designating one-way street.
2. Signs should be installed on near and far side of intersection facing both directions of traffic.
3. One Way signs may be installed center mounted on top of Stop signs.
4. Turn Restriction signs (e.g. No Right Turn) may be used to supplement One Way sign at signalized intersections or intersection of two arterials.
5. Refer to Commonly Used Signs: Fabrication Detail for R6-2L/R.
6. R6-2L/R Special Except Bikes (#3 and #4) must be coordinated with CDOT's Bike Coordinator.

STANDARD APPLICATIONS

Location:	intersection (near right far left for intersections), alley
Distance from Property Line (0+00):	0'-5"
Number of signs per Block Face:	varies
Types of Poles:	dig, drill, light pole, traffic signal pole
Mounting Height:	7'-0" clearance to bottom of sign
Mounting:	center
Angle:	90 degrees
Sign Blank:	single-sided
Co-Mounting:	May be installed with Stop signs, street name signs, Yield signs and Do Not Enter signs

MUTCD FOOTNOTE: These guidelines are not intended to conflict in any way with either the USDOT Manual of Uniform Traffic Control Devices (MUTCD) or the IDOT Standard Highway Manual. In the event of any present or future conflict, the information provided in the MUTCD or IDOT Signs Manual takes precedence.



Exception:

1. One Way signs should be installed at alleys and commercial/industrial parking lots generating large amounts of traffic.
2. One Way signs mounted over Stop or Yield signs will exceed 10'-7" mounting height.

Note:

For Turn restriction signs, see Section 1.3.1, Turning.

MUTCD:

Part 2B: Regulatory Signs, Barricades, and Gates
Section 2B-40: One Way Signs

ILLINOIS COMPILED STATUTES

Illinois Vehicle Code: (625 ILCS 5)
Section 11-208(a) 4: Powers of Local Authorities

MUNICIPAL CODE OF CHICAGO

Chapter 9-20: Movement of Traffic
Section 9-20-010: One-Way Streets

ORDINANCE REQUIREMENTS

Yes. Ordinance is required through city council for street direction changes (9-20-010).



1.3.5 Pedestrian Series (R9)

Signs	Code	Size	Shape	Colors
1. No Pedestrian Crossing (Symbol)	R9-3	18 x 18	Rectangle	R-B/W
2. Use Crosswalk with arrow	R9-3bP	18 x 12	Rectangle	B/W

GENERAL GUIDELINES

1. Installation and location of signs should be based on engineering and traffic study by CDOT. Authorization by a City Traffic Engineer for installation of new signs.
2. All signs should face sidewalks.

STANDARD APPLICATIONS

Location:	intersection
Distance from Property Line (0+00):	0
Number of signs per Block Face:	1
Types of Poles:	Dig, drill, signal pole, light pole
Mounting Height:	7'-0" clearance to bottom of sign
Mounting:	center
Angle:	90 degrees
Sign Blank:	single-sided
Co-Mounting:	Can be mounted with other intersection Regulatory Traffic or Warning signs.
Exception:	Does not apply
Note:	No Pedestrian Crossing signs should be installed with R9-3bP sign to show direction to nearest cross walk.

MUTCD

Part 2B: Regulatory Signs, Barricades, and Gates
Section 2B-51: Pedestrian Crossing signs

ILLINOIS COMPILED STATUTES

Illinois Vehicle Code: (625 ILCS 5)
Section 11-208(a) 12: Powers of Local Authorities

MUNICIPAL CODE OF CHICAGO

Chapter 9-60: Pedestrians' Right and Duties
Section 9-60-010: Crosswalks Authorized

ORDINANCE REQUIREMENTS

No. Ordinance not required.



1.3.6 Traffic Signal Control Series (R10)

Signs	Code	Size	Shape	Colors
1. Push Button for (Symbol) Walk Signal	R10-3	9 x 12	Rectangle	B/W
2. Left on Green Arrow Only	R10-5	24 x 30	Rectangle	B/W
3. Stop Here Left Arrow on Red	R10-6L	24 x 30	Rectangle	B/W
4. Stop Here Right Arrow on Red	R10-6R	24 x 30	Rectangle	B/W
5. Do Not Block Intersection	R10-7	24 x 30	Rectangle	B/W
6. Left Turn Signal	R10-10	24 x 30	Rectangle	B/W
7. No Turn on Red	R10-11B	24 x 24	Rectangle	B/W
8. No Turn on Red 7am-7pm	R10-11C	24 x 24	Rectangle	B/W
9. Oncoming Traffic Has Extended Green	W25-1	24 x 30	Rectangle	B/Y
10. Oncoming Traffic May Have Extended Green	W25-2	24 x 30	Rectangle	B/Y



R10-11C

GENERAL GUIDELINES

1. Installation of signs should be based on traffic and engineer study performed by CDOT. Authorization by a Traffic Engineer is required for installation of new signs.
2. Location of signs on traffic signal and mast arm shall be based on sketch of typical layout included in exhibit *Regulatory Sign Installation on Traffic Signals*.
3. Pedestrian activated signal sign (R10-3) shall be placed immediately above push button.
4. “Left on Green Arrow Only” (#2) is the only sign allowed by MUTCD for protected-only movements.

STANDARD APPLICATIONS

Location:	intersection
Distance from Property Line (0+00):	0
Number of signs per Block Face:	1
Types of Poles:	traffic signal, mast arm
Mounting Height:	7'-0" to bottom of sign. (traffic signal); center on mast arm
Mounting:	center (traffic signal); mast arm mount (mast arm)
Angle:	90 degrees
Sign Blank:	single-sided

MUTCD FOOTNOTE: These guidelines are not intended to conflict in any way with either the USDOT Manual of Uniform Traffic Control Devices (MUTCD) or the IDOT Standard Highway Manual. In the event of any present or future conflict, the information provided in the MUTCD or IDOT Signs Manual takes precedence.



Co-Mounting:	can be installed with other intersection Regulatory Traffic signs
Exception:	signs may be installed outside 7' to 10'-7" when required to clear signal heads
Note:	Does not apply

MUTCD

- Part 2B: Regulatory Signs, Barricades, and Gates
- Section 2B-52: Traffic Signal Pedestrian and Bicycle Actuation
- Section 2B-53: Traffic Signal Signs
- Part 2C: Warning Signs and Object Markers
- Section 2C-48: Traffic Signal Signs

ILLINOIS COMPILED STATUTES

- Illinois Vehicle Code: (625 ILCS 5)
- Section 11-208(a) 2,9: Powers of Local Authorities.

MUNICIPAL CODE OF CHICAGO

- Chapter 9-16: Turning Movements
- Section 9-16-030: Turns on Red Signals

ORDINANCE REQUIREMENTS

No. Ordinance not required.

MUTCD FOOTNOTE: These guidelines are not intended to conflict in any way with either the USDOT Manual of Uniform Traffic Control Devices (MUTCD) or the IDOT Standard Highway Manual. In the event of any present or future conflict, the information provided in the MUTCD or IDOT Signs Manual takes precedence.



2 REGULATORY PARKING SIGNS

2.1 No Parking Series

2.1.1 No Parking (At All Times) and No Stopping/No Standing (R7)

Signs	Code	Size	Shape	Colors
1. No Parking (Symbol) RA Tow Zone	R7-1-1	18 x 18	Rectangle	B-R/W, W/R
2. No Parking (Symbol) LA Tow Zone	R7-1-3	18 x 18	Rectangle	B-R/W, W/R
3. No Parking (Symbol) Tow Zone	R7-1-4	18 x 18	Rectangle	B-R/W, W/R
4. No Truck Parking (Symbol) Tow Zone	R7-1-70	18 x 18	Rectangle	B-R/W, W/R
5. No Parking (Symbol) No Stopping No Standing Tow Zone RA	R7-401-1	18 x 18	Rectangle	B-R/W, W/R
6. No Parking (Symbol) No Stopping No Standing Tow Zone LA	R7-401-3	18 x 18	Rectangle	B-R/W, W/R
7. No Parking (Symbol) No Stopping No Standing Tow Zone	R7-401-4	18 x 18	Rectangle	B-R/W, W/R
8. No Parking (Symbol) No Stopping No Standing Tow Zone RA (Day)-(Hour)	R7-402-1	18 x 24	Rectangle	B-R/W, W/R
9. No Parking (Symbol) No Stopping No Standing Tow Zone LA (Day)-(Hour)	R7-402-3	18 x 24	Rectangle	B-R/W, W/R
10. No Parking (Symbol) No Stopping No Standing Tow Zone (Day)-(Hour)	R7-402-4	18 x 24	Rectangle	B-R/W, W/R



R7-1-1



R7-1-70



R7-401-3



R7-402-1

GENERAL GUIDELINES

1. Install on light poles whenever possible.
2. No Parking/Tow Zone signs shall be installed under following circumstances: corner clearances, driveways, fire lanes, handicapped spaces, theater parking and loading zones.
3. Signs with arrows are installed at beginning and end of restricted parking zone. Provide intermediate sign if zone is longer than 300ft.
4. Signs without arrows should be placed above signs with arrows.
5. Signs should be placed above signs without tow zone restrictions.

MUTCD FOOTNOTE: These guidelines are not intended to conflict in any way with either the USDOT Manual of Uniform Traffic Control Devices (MUTCD) or the IDOT Standard Highway Manual. In the event of any present or future conflict, the information provided in the MUTCD or IDOT Signs Manual takes precedence.

**STANDARD APPLICATIONS**

Location:	midblock
Distance from Property Line (0+00):	300 ft. block face: 81 feet 600 ft. block face: 200 ft, 400 ft
Number of signs per Block Face:	300 ft. block face: 1; 600 ft. block face: 2
Types of Poles:	dig, drill, light pole
Mounting Height:	between 7'0" and 10'-7"
Mounting:	center
Angle:	signs with arrow: 30 degrees; signs without arrow: 90 degrees
Sign Blank:	single-sided
Co-Mounting:	Can be mounted with other Regulatory Parking (R7 series), Informational or Non Traffic signs.
Exception:	Provide additional signs at 200ft increments on blocks longer than 600ft
Note:	Distances and number of signs per block face apply to signs without arrows

MUTCD

Part 2B: Regulatory Signs, Barricades, and Gates
Section 2B-46: Parking, Standing and Stopping Signs

ILLINOIS COMPILED STATUTES

Illinois Vehicle Code: (625 ILCS 5)
Section 11-208(a) 1: Powers of Local Authorities

MUNICIPAL CODE OF CHICAGO

Chapter 9-64: Parking Regulations
Section 9-64-010: Applicability

ORDINANCE REQUIREMENTS

Yes. Ordinance required for time-based parking restrictions for No Stopping/No Standing signs.



2.1.2 Specified Hours (R7)

Signs	Code	Size	Shape	Colors
1. No Parking (Symbol) 7AM-9AM M-F Tow Zone RA	R7-2-1	18 x 18	Rectangle	B-R/W, W/R
2. No Parking (Symbol) 7AM-9AM M-F Tow Zone LA	R7-2-3	18 x 18	Rectangle	B-R/W, W/R
3. No Parking (Symbol) 7AM-9AM M-F Tow Zone	R7-2-4	18 x 18	Rectangle	B-R/W, W/R
4. No Parking (Symbol) 4PM-6PM M-F Tow Zone RA	R7-2-11	18 x 18	Rectangle	B-R/W, W/R
5. No Parking (Symbol) 4PM-6PM M-F Tow Zone LA	R7-2-13	18 x 18	Rectangle	B-R/W, W/R
6. No Parking (Symbol) 4PM-6PM M-F Tow Zone	R7-2-14	18 x 18	Rectangle	B-R/W, W/R
7. No Parking (Symbol) 7AM-9AM 4PM-6PM M-F Tow Zone RA	R7-2-21	18 x 18	Rectangle	B-R/W, W/R
8. No Parking (Symbol) 7AM-9AM 4PM-6PM M-F Tow Zone LA	R7-2-23	18 x 18	Rectangle	B-R/W, W/R
9. No Parking (Symbol) 7AM-9AM 4PM-6PM M-F Tow Zone	R7-2-24	18 x 18	Rectangle	B-R/W, W/R
10. No Parking (Symbol) Special Hours, Days, Tow Zone RA	R7-2-81	18 x 18	Rectangle	B-R/W, W/R
11. No Parking (Symbol) Special Hours, Days, Tow Zone LA	R7-2-83	18 x 18	Rectangle	B-R/W, W/R
12. No Parking (Symbol) Special Hours, Days, Tow Zone	R7-2-84	18 x 18	Rectangle	B-R/W, W/R



R7-2-1



R7-2-11



R7-2-21



R7-2-81

GENERAL GUIDELINES

1. Install signs on light poles whenever possible.
2. Signs with arrows are installed at beginning and end of restricted parking zone. Provide intermediate sign if parking zone is longer than 300ft.
3. Signs with no arrows should be placed above signs with arrows.
4. Signs with tow zone restrictions should be placed above signs with no tow zone restrictions.
5. Regulatory parking signs should not be installed on same pole as Traffic Regulatory or Warning signs.
6. If text does not fit on a 18 x 18 sign, increase sign size to 18 x 24.

**STANDARD APPLICATIONS**

Location:	midblock
Distance from Property Line (0+00):	300 ft. block face: 81 feet 600 ft. block face: 200 ft, 400 ft
Number of signs per Block Face:	300 ft. block face: 1; 600 ft. block face: 2
Types of Poles:	dig, drill, light pole
Mounting Height:	between 7'0" and 10'-7"
Mounting:	center
Angle:	signs with arrow: 30 degrees; signs without arrow: 90 degrees
Sign Blank:	single-sided
Co-Mounting:	Can be mounted with other Regulatory Parking (R7 series), Informational or Non-Traffic signs.
Exception:	Provide additional signs at 200ft increments on blocks longer than 600ft
Note:	Distances and number of signs per block face apply to signs without arrows

MUTCD

Part 2B: Regulatory Signs, Barricades, and Gates
Section 2B-46: Parking, Standing and Stopping Signs

ILLINOIS COMPILED STATUTES

Illinois Vehicle Code: (625 ILCS 5)
Section 11-208(a) 1: Powers of Local Authorities

MUNICIPAL CODE OF CHICAGO

Chapter 9-64: Parking Regulations
Section 9-64-080: Parking Restricted on Certain Days or Hours

ORDINANCE REQUIREMENTS

Yes. Ordinance required for time-based parking restrictions.



2.1.3 Specified Events (R7)

Signs	Code	Size	Shape	Colors
1. No Parking (Symbol) During Ball Games Tow Zone	R7-301-14	18 x 18	Rectangle	B-R/W, W/R
2. No Parking (Symbol) Days of Ball Games Tow Zone	R7-301-24	18 x 18	Rectangle	B-R/W, W/R
3. No Parking (Symbol) During Stadium Events Tow Zone	R7-301-34	18 x 18	Rectangle	B-R/W, W/R
4. No Parking (Symbol) During Stadium Events Except Residents Tow Zone	R7-301-44	18 x 18	Rectangle	B-R/W, W/R



R7-301-14



R7-301-24



R7-301-34



R7-301-44

GENERAL GUIDELINES

1. Signs should be mounted on light poles whenever possible.
2. Signs with no arrows should be placed above signs with arrows.
3. Signs with tow zone restrictions should be placed above signs with no tow zone restrictions.
4. Signs should not be installed on same pole as Regulatory Traffic or Warning signs.

STANDARD APPLICATIONS

Location:	midblock
Distance from Property Line (0+00):	300 ft. block face: 81 feet 600 ft. block face: 200 ft
Number of signs per Block Face:	300 ft. block face: 1; 600 ft. block face: 2
Types of Poles:	dig, drill, light pole
Mounting Height:	between 7'0" and 10'-7"
Mounting:	center
Angle:	signs with arrow: 30 degrees; signs without arrow: 90 degrees
Sign Blank:	single-sided
Co-Mounting:	Can be mounted with other Regulatory Parking (R7 series), Informational or Non Traffic signs.
Exception:	Provide additional signs at 200ft increments on blocks longer than 600ft

MUTCD FOOTNOTE: These guidelines are not intended to conflict in any way with either the USDOT Manual of Uniform Traffic Control Devices (MUTCD) or the IDOT Standard Highway Manual. In the event of any present or future conflict, the information provided in the MUTCD or IDOT Signs Manual takes precedence.



STANDARD APPLICATIONS

Note:

- Ball game signs are installed in designated areas surrounding Wrigley Field and Cominsky Park.
 - Stadium signs are installed in designated areas around United Center.
-

MUTCD

Part 2B: Regulatory Signs, Barricades, and Gates
Section 2B-46: Parking, Standing and Stopping Signs

ILLINOIS COMPILED STATUTES

Illinois Vehicle Code: (625 ILCS 5)
Section 11-208(a) 1: Powers of Local Authorities
Section 9-68-040: Athletic Events at Wrigley Field

MUNICIPAL CODE OF CHICAGO

Chapter 9-68: Restricted Parking
Section 9-68-040: Athletic Events at Wrigley Field
Chapter 9-64: Parking Regulations
Section 9-64-010: Applicability
Section 9-64-080: Parking Restricted on Certain Days or Hours

ORDINANCE REQUIREMENTS

Yes. Ordinance required for time-based parking restrictions.

MUTCD FOOTNOTE: These guidelines are not intended to conflict in any way with either the USDOT Manual of Uniform Traffic Control Devices (MUTCD) or the IDOT Standard Highway Manual. In the event of any present or future conflict, the information provided in the MUTCD or IDOT Signs Manual takes precedence.



2.2 Time Limit Parking Series (R7)

Signs	Code	Size	Shape	Colors
1. One Hour Parking (Days/Times) RA	R7-5-11	18 x 18	Rectangle	G/W
2. One Hour Parking (Days/Times) LA	R7-5-13	18 x 18	Rectangle	G/W
3. One Hour Parking (Days/Times)	R7-5-14	18 x 18	Rectangle	G/W
4. Two Hour Parking (Days/Times) RA	R7-5-1	18 x 18	Rectangle	G/W
5. Two Hour Parking (Days/Times) LA	R7-5-3	18 x 18	Rectangle	G/W
6. Two Hour Parking (Days/Times)	R7-5-4	18 x 18	Rectangle	G/W



R7-5-11



R7-5-1

GENERAL GUIDELINES

1. Install signs on light poles when possible.
2. Signs with arrows are installed at beginning and end of regulatory parking zone. Provide intermediate sign if zone is longer than 300 ft.
3. Signs with no arrows should be placed above signs with arrows.
4. Signs with No Parking restrictions should be placed above Time Limit Parking series.
5. Should not be installed on same pole as Traffic Regulatory or Warning signs.
6. If text does not fit on a 18 x 18 sign, increase sign size to 18 x 24.

STANDARD APPLICATIONS

Location:	midblock
Distance from Property Line (0+00):	300 ft. block face: 81 feet 600 ft. block face: 200 ft, 400 ft
Number of signs per Block Face:	300 ft. block face: 1; 600 ft. block face: 2
Types of Poles:	dig, drill, light pole
Mounting Height:	between 7'0" and 10'-7"
Mounting:	center
Angle:	signs with arrow: 30 degrees; signs without arrow: 90 degrees
Sign Blank:	single-sided
Co-Mounting:	Can be mounted with other Regulatory Parking (R7 series), Informational or Non-Traffic signs.

MUTCD FOOTNOTE: These guidelines are not intended to conflict in any way with either the USDOT Manual of Uniform Traffic Control Devices (MUTCD) or the IDOT Standard Highway Manual. In the event of any present or future conflict, the information provided in the MUTCD or IDOT Signs Manual takes precedence.



Exception:	Provide additional signs at 200ft increments on blocks longer than 600ft
Note:	Distances and number of signs per block face apply to signs without arrows

MUTCD

Part 2B: Regulatory Signs, Barricades, and Gates
Section 2B-46: Parking, Standing and Stopping Signs

ILLINOIS COMPILED STATUTES

Illinois Vehicle Code: (625 ILCS 5)
Section 11-208(a) 1: Powers of Local Authorities

MUNICIPAL CODE OF CHICAGO

Chapter 9-64: Parking Regulations
Section 9-64-080: Parking Restricted on Days or Hours

ORDINANCE REQUIREMENTS

Yes. Ordinance required for time-based parking signs.

MUTCD FOOTNOTE: These guidelines are not intended to conflict in any way with either the USDOT Manual of Uniform Traffic Control Devices (MUTCD) or the IDOT Standard Highway Manual. In the event of any present or future conflict, the information provided in the MUTCD or IDOT Signs Manual takes precedence.



2.3 Permit Parking Series (R7)

Signs	Code	Size	Shape	Colors
1. No Parking (Symbol) Hours/Days Exc Zone #__Perm RA	R7-300-1	18 x 24	Rectangle	B-R/W, W/R
2. No Parking (Symbol) Hours/Days Exc Zone #__Perm LA	R7-300-3	18 x 24	Rectangle	B-R/W, W/R
3. No Parking (Symbol) Hours/Days Exc Zone #__	R7-300-4	18 x 24	Rectangle	B-R/W, W/R
4. No Parking (Symbol) (Anytime) or (Hours) #__ Perm RA	R7-300-1A	18 x 18	Rectangle	B-R/W, W/R
5. No Parking (Symbol) (Anytime) or (Hours) #__ Perm LA	R7-300-3A	18 x 18	Rectangle	B-R/W, W/R
6. No Parking (Symbol) (Anytime) or (Hours) #__ Perm	R7-300-4A	18 x 18	Rectangle	B-R/W, W/R



R7-300-1



R7-300-1A

GENERAL GUIDELINES

1. Install signs on light poles when possible.
2. Signs with arrows should be installed at beginning and end of regulatory parking zone.
3. Permit parking signs should be installed above Parking Regulation signs with arrows.
4. Signs with Tow Zones should be installed above signs without Tow Zones.
5. Signs should not be installed on same pole as Regulatory Traffic Restriction signs.
6. Residential signs should not be posted on curb clearance, or within a no parking tow zone sign.
7. State when, or when not to use arrows.

STANDARD APPLICATIONS

Location:	midblock
Distance from Property Line (0+00):	300 ft. block face: 81 feet 600 ft. block face: 200 ft, 400 ft
Number of signs per Block Face:	300 ft. block face: 1; 600 ft. block face: 2
Types of Poles:	dig, drill, light pole
Mounting Height:	between 7'0" and 10'-7"
Mounting:	center
Angle:	signs with arrow: 30 degrees; signs without arrow: 90 degrees
Sign Blank:	single-sided

MUTCD FOOTNOTE: These guidelines are not intended to conflict in any way with either the USDOT Manual of Uniform Traffic Control Devices (MUTCD) or the IDOT Standard Highway Manual. In the event of any present or future conflict, the information provided in the MUTCD or IDOT Signs Manual takes precedence.



STANDARD APPLICATIONS

Co-Mounting:

Can be mounted with other Regulatory Parking (R7 series), Informational or Non-Traffic signs.

Exception:

Provide additional signs at 200ft increments on blocks longer than 600ft

Note:

- Distances and number of signs per block face apply to signs without arrows.
 - Permit Parking Series signs apply to both residential and industrial permit parking.
-

MUTCD

Part 2B: Regulatory Signs, Barricades, and Gates
Section 2B-46: Parking, Standing and Stopping Signs

ILLINOIS COMPILED STATUTES

Illinois Municipal Code (65 ILCS 5)
Section 11-80-2a: Residential Parking Only

MUNICIPAL CODE OF CHICAGO

Chapter 9-64: Parking Regulations
Section 9-64-090: Residential Permit Parking
Section 9-64-091: Industrial Permit Parking

ORDINANCE REQUIREMENTS

Yes. Ordinance required for permit parking signs.

MUTCD FOOTNOTE: These guidelines are not intended to conflict in any way with either the USDOT Manual of Uniform Traffic Control Devices (MUTCD) or the IDOT Standard Highway Manual. In the event of any present or future conflict, the information provided in the MUTCD or IDOT Signs Manual takes precedence.



2.4 Loading Zone Series (R7)

Signs	Code	Size	Shape	Colors
1. No Parking(Symbol) Loading Zone Tow Zone RA	R7-601-1	18 x 18	Rectangle	B-R/W, W/R
2. No Parking(Symbol) Loading Zone Tow Zone LA	R7-601-3	18 x 18	Rectangle	B-R/W, W/R
3. No Parking(Symbol) Loading Zone Tow Zone	R7-601-4	18 x 18	Rectangle	B-R/W, W/R
4. No Parking(Symbol) Loading Zone Special Hours TZ RA	R7-601-91	18 x 18	Rectangle	B-R/W, W/R
5. No Parking(Symbol) Loading Zone Special Hours TZ LA	R7-601-93	18 x 18	Rectangle	B-R/W, W/R
6. No Parking(Symbol) Loading Zone Special Hours TZ	R7-601-94	18 x 18	Rectangle	B-R/W, W/R
7. Valet Parking TZ	Special	18 x 18	Rectangle	B-R/W, W/R
8. 15 Minute Standing Zone Use Flashers Tow Zone RA	R7-602-1	18 x 18	Rectangle	B-R/W, W/R
9. 15 Minute Standing Zone Use Flashers Tow Zone LA	R7-602-3	18 x 18	Rectangle	B-R/W, W/R
10. 15 Minute Standing Zone Use Flashers Tow Zone	R7-602-4	18 x 18	Rectangle	B-R/W, W/R
11. 15 Minute Standing Zone Use Flasher TZ Hours/Days RA	R7-602-11	18 x 18	Rectangle	B-R/W, W/R
12. 15 Minute Standing Zone Use Flashers TZ Hours/Days LA	R7-602-13	18 x 18	Rectangle	B-R/W, W/R
13. 15 Minute Standing Zone Use Flashers TZ Hours/Days	R7-602-14	18 x 18	Rectangle	B-R/W, W/R
14. 30 Minute Standing Zone Use Flashers Tow Zone RA	R7-602-31	18 x 18	Rectangle	B-R/W, W/R
15. 30 Minute Standing Zone Use Flashers Tow Zone LA	R7-602-33	18 x 18	Rectangle	B-R/W, W/R
16. 30 Minute Standing Zone Use Flashers Tow Zone	R7-602-34	18 x 18	Rectangle	B-R/W, W/R
17. 30 Minute Standing Zone Use Flashers TZ Hours/Days RA	R7-602-41	18 x 18	Rectangle	B-R/W, W/R
18. 30 Minute Standing Zone Use Flashers TZ Hours/Days LA	R7-602-43	18 x 18	Rectangle	B-R/W, W/R
19. 30 Minute Standing Zone Use Flashers TZ Hours/Days	R7-602-44	18 x 18	Rectangle	B-R/W, W/R
20. No Parking (Symbol) Day Care Loading Zone (Hours) and/or (Days) TZ RA	R7-601-81	18 x 18	Rectangle	B-R/W, W/R
21. No Parking (Symbol) Day Care Loading Zone (Hours) and/or (Days) TZ LA	R7-601-83	18 x 18	Rectangle	B-R/W, W/R

MUTCD FOOTNOTE: These guidelines are not intended to conflict in any way with either the USDOT Manual of Uniform Traffic Control Devices (MUTCD) or the IDOT Standard Highway Manual. In the event of any present or future conflict, the information provided in the MUTCD or IDOT Signs Manual takes precedence.



22. No Parking (Symbol) Day Care Loading Zone (Hours)
and/or (Days) TZ NA

R7-601-84 18 x 18 Rectangle B-R/W



R7-601-4



R7-601-91



R7-602-1



R7-602-11



R7-602-31



R7-601-41



R7-601-81



Special

GENERAL GUIDELINES

1. Install signs at beginning and end of loading zone established by ordinance.
2. All loading zone restrictions should include “Tow Zone.”
3. Signs with arrows should be installed below Regulatory Parking signs without arrows.
4. Signs with Tow Zone restrictions should be installed above signs without Tow Zone restrictions.
5. All businesses seeking a standing/loading zone, valet parking, or day care loading zone must refer to the [CDOT Standing/Loading Zone Application](#).

STANDARD APPLICATIONS

Location:	midblock
Distance from Property Line (0+00):	as specified by ordinance
Number of signs per Block Face:	2
Types of Poles:	dig, drill, light pole
Mounting Height:	between 7'0" and 10'-7"
Mounting:	center
Angle:	signs with arrow: 30 degrees; signs without arrow: 90 degrees
Sign Blank:	single-sided
Co-Mounting:	<ol style="list-style-type: none"> 1. Valet parking must be installed with Loading Zone sign. 2. Loading Zone signs can be mounted with other Regulatory Parking, Informational, and Non-Traffic signs.
Exception:	does not apply
Note:	<ul style="list-style-type: none"> • Valet parking is to be posted only during periods valet service is being provided. • For Accessible Loading Zone signs, see Section 2.6, Accessible Parking Series.



MUTCD

Part 2B: Regulatory Signs, Barricades, and Gates
Section 2B-46: Parking, Standing and Stopping Signs

ILLINOIS COMPILED STATUTES

Illinois Vehicle Code: (625 ILCS 5)
Section 11-208(a) 1: Powers of Local Authorities

MUNICIPAL CODE OF CHICAGO

Chapter 9-64: Parking Regulations
Section 9-64-160: Curb Loading Zones

ORDINANCE REQUIREMENTS

Yes. Ordinance required for loading zone and standing zone signs.

MUTCD FOOTNOTE: These guidelines are not intended to conflict in any way with either the USDOT Manual of Uniform Traffic Control Devices (MUTCD) or the IDOT Standard Highway Manual. In the event of any present or future conflict, the information provided in the MUTCD or IDOT Signs Manual takes precedence.



2.5 Bus & Taxi Zone Series (R7)

Signs	Code	Size	Shape	Colors
1. No Parking(Symbol) Bus Stop Tow Zone RA	R7-207-1	18 x 18	Rectangle	B-R/W, W/R
2. No Parking(Symbol) Bus Stop Tow Zone LA	R7-207-3	18 x 18	Rectangle	B-R/W, W/R
3. No Parking(Symbol) Bus Stop Tow Zone	R7-207-4	18 x 18	Rectangle	B-R/W, W/R
4. No Parking(Symbol) Bus Stop M-F Tow Zone RA	R7-207-11	18 x 24	Rectangle	B-R/W, W/R
5. No Parking(Symbol) Bus Stop M-F Tow Zone LA	R7-207-13	18 x 24	Rectangle	B-R/W, W/R
6. No Parking(Symbol) Bus Stop M-F Tow Zone	R7-207-14	18 x 24	Rectangle	B-R/W, W/R
7. No Parking(Symbol) Bus Stop M-S Tow Zone RA	R7-207-16	18 x 24	Rectangle	B-R/W, W/R
8. No Parking(Symbol) Bus Stop M-S Tow Zone LA	R7-207-18	18 x 24	Rectangle	B-R/W, W/R
9. No Parking(Symbol) Bus Stop M-S Tow Zone	R7-207-19	18x24	Rectangle	B-R/W, W/R
10. No Parking (Symbol) Charter Bus Stop Tow Zone RA	R7-207-31	18 x 18	Rectangle	B-R/W, W/R
11. No Parking (Symbol) Charter Bus Stop Tow Zone LA	R7-207-33	18 x 18	Rectangle	B-R/W, W/R
12. No Parking (Symbol) Charter Bus Stop Tow Zone	R7-207-34	18 x 18	Rectangle	B-R/W, W/R
13. No Parking(Symbol) Charter Bus Stand Tow Zone RA	R7-207-61	18 x 18	Rectangle	B-R/W, W/R
14. No Parking(Symbol) Charter Bus Stand Tow Zone LA	R7-207-63	18 x 18	Rectangle	B-R/W, W/R
15. No Parking(Symbol) Charter Bus Stand Tow Zone	R7-207-64	18 x 18	Rectangle	B-R/W, W/R
16. No Parking(Symbol) Taxi Stand (Hours)(Days) Tow Zone RA	R7-207-81	18 x 18	Rectangle	B-R/W, W/R
17. No Parking(Symbol) Taxi Stand (Hours)(Days) Tow Zone LA	R7-207-83	18 x 18	Rectangle	B-R/W, W/R
18. No Parking(Symbol) Taxi Stand (Hours)(Days)Tow Zone	R7-207-84	18 x 18	Rectangle	B-R/W, W/R



R7-207-1



R7-207-13



R7-207-16



R7-207-34



R7-207-64



R7-207-81

GENERAL GUIDELINES

1. Install signs on light poles when possible.
2. Signs with Tow Zone restrictions should be installed above signs without Tow Zone restrictions.
3. No Parking without arrows should not be placed on same pole as 24-Hour Bus, Cab Zone signs.
4. No Parking/Taxi Stand signs should provide 20ft. of loading for each cab allowed.
5. Signs not required on streets where No Parking Tow Zone restrictions cover entire block.

STANDARD APPLICATIONS

Location:	special zones
Distance from Property Line (0+00):	1. As specified by guidelines for bus stops. 2. As specified by ordinance for taxi stands.
Number of signs per Block Face:	intersection bus stops & taxi stands: 1; midblock bus stops & taxi stands: 2
Types of Poles:	dig, drill, light pole
Mounting Height:	between 7'0" and 10'-7"
Mounting:	center
Angle:	signs with arrow: 30 degrees; signs without arrow: 90 degrees
Sign Blank:	single-sided
Co-Mounting:	Can be mounted with other Regulatory Parking, Informational, and Non-Traffic signs.
Exception:	does not apply
Note:	<ul style="list-style-type: none"> • For additional taxi stand signs, see Section 4.5 (Transportation Series). • Bus Stop signs are provided and installed by the CTA.

MUTCD

Part 2B: Regulatory Signs, Barricades, and Gates
Section 2B-46: Parking, Standing and Stopping Signs

MUTCD FOOTNOTE: These guidelines are not intended to conflict in any way with either the USDOT Manual of Uniform Traffic Control Devices (MUTCD) or the IDOT Standard Highway Manual. In the event of any present or future conflict, the information provided in the MUTCD or IDOT Signs Manual takes precedence.



ILLINOIS COMPILED STATUTES

Illinois Vehicle Code: (625 ILCS 5)

Section 11-208(a) 1: Powers of Local Authorities

MUNICIPAL CODE OF CHICAGO

Chapter 9-64: Parking Regulations

Section 9-64-140: Common Carrier Vehicle Stops and Stands

ORDINANCE REQUIREMENTS

Yes. Ordinance required for loading zone and standing zone signs.



2.6 Accessible Parking Series (R7)

Signs	Code	Size	Shape	Colors
1. (Accessible Symbol) Exc Permit #__ RA	R7-8-1	18 x 18	Rectangle	Bl/W
2. (Accessible Symbol) Exc Permit #__ LA	R7-8-3	18 x 18	Rectangle	Bl/W
3. Loading Zone (Accessible Symbol) Tow Zone RA	R7-8-11	18 x 18	Rectangle	R/W,Bl/W,W/ R
4. Loading Zone (Accessible Symbol) Tow Zone LA	R7-8-13	18 x 18	Rectangle	R/W,Bl/W,W/ R
5. Loading Zone (Accessible Symbol) Tow Zone	R7-8-14	18 x 18	Rectangle	R/W,Bl/W,W/ R
6. Loading Zone (Accessible Symbol) (Hours)(Days) Tow Zone RA	R7-8-21	18 x 18	Rectangle	R/W,Bl/W,W/ R
7. Loading Zone (Accessible Symbol) (Hours)(Days) Tow Zone LA	R7-8-23	18 x 18	Rectangle	R/W,Bl/W,W/ R
8. Loading Zone (Accessible Symbol) (Hours)(Days) Tow Zone	R7-8-24	18 x 18	Rectangle	R/W,Bl/W,W/ R
9. Reserved Parking (Accessible Symbol) RA	R7-8-25	18 x 18	Rectangle	Bl/W,G/W
10. Reserved Parking (Accessible Symbol)	R7-8-26	18 x 18	Rectangle	Bl/W,G/W
11. Reserved Parking (Accessible Symbol) LA	R7-8-27	18 x 18	Rectangle	Bl/W,G/W
12. Reserved Parking (Accessible Symbol)(Hours)(Days) Tow Zone RA	R7-8-31	18 x 24	Rectangle	Bl/W,G/W,W/ R
13. Reserved Parking (Accessible Symbol)(Hours)(Days) Tow Zone LA	R7-8-33	18 x 24	Rectangle	Bl/W,G/W,W/ R
14. Reserved Parking (Accessible Symbol)(Hours)(Days) Tow Zone	R7-8-34	18 x 24	Rectangle	Bl/W,G/W,W/ R
15. Reserved Parking (Accessible Symbol)("Fine")Tow Zone RA	R7-8-41	18 x 18	Rectangle	Bl/W,G/R/W, W/R
16. Reserved Parking (Accessible Symbol)("Fine") Tow Zone LA	R7-8-43	18 x 18	Rectangle	Bl/W,G/R/W, W/R
17. Reserved Parking (Accessible Symbol)("Fine") Tow Zone	R7-8-44	18 x 18	Rectangle	Bl/W,G/R/W, W/R



R7-8-1



R7-8-11



R7-8-21



R7-8-25

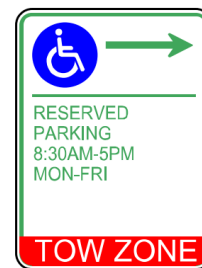

R7-8-31



R7-8-41

MUTCD FOOTNOTE: These guidelines are not intended to conflict in any way with either the USDOT Manual of Uniform Traffic Control Devices (MUTCD) or the IDOT Standard Highway Manual. In the event of any present or future conflict, the information provided in the MUTCD or IDOT Signs Manual takes precedence.

**GENERAL GUIDELINES**

1. Install signs or markings at beginning and end of parking zone established by ordinance.

STANDARD APPLICATIONS

Location:	special zones
Distance from Property Line (0+00):	As specified by ordinance.
Number of signs per Block Face:	2
Types of Poles:	dig, drill, light pole
Mounting Height:	between 7'0" and 10'-7"
Mounting:	center
Angle:	signs with arrow: 30 degrees; signs without arrow: 90 degrees
Sign Blank:	single-sided
Co-Mounting:	Can be mounted with other Regulatory Parking, Informational, and Non-Traffic signs.
Exception:	does not apply
Note:	does not apply

MUTCD

Part 2B: Regulatory Signs, Barricades, and Gates
 Section 2B-46: Parking, Standing and Stopping Signs

ILLINOIS COMPILED STATUTES

Illinois Vehicle Code: (625 ILCS 5)
 Section 11-208 (a) 14: Powers of Local Authorities
 Section 11-1301.1: Persons with Disabilities
 Section 11-1301.2: Special Decals for a Person with Disabilities
 Section 11-1301.3: Unauthorized use of Parking Places Reserved for Persons with Disabilities

MUNICIPAL CODE OF CHICAGO

Chapter 9-64: Parking Regulations
 Section 9-64-050: Parking Restrictions—Handicapped Parking

ORDINANCE REQUIREMENTS

Yes. Ordinance required for accessible parking signs.

MUTCD FOOTNOTE: These guidelines are not intended to conflict in any way with either the USDOT Manual of Uniform Traffic Control Devices (MUTCD) or the IDOT Standard Highway Manual. In the event of any present or future conflict, the information provided in the MUTCD or IDOT Signs Manual takes precedence.



2.7 Angled Parking Control Series (R7)

Signs	Code	Size	Shape	Colors
1. Parking (Symbol) Parallel Parking Only RA	R7-11-1	18 x 18	Rectangle	G/W
2. Parking (Symbol) Parallel Parking Only LA	R7-11-3	18 x 18	Rectangle	G/W
3. Parking (Symbol) Parallel Parking Only	R7-11-4	18 x 18	Rectangle	G/W
4. Parking (Symbol) Diagonal Only RA	R7-11-11	18 x 18	Rectangle	G/W
5. Parking (Symbol) Diagonal Only LA	R7-11-13	18 x 18	Rectangle	G/W
6. Parking (Symbol) Diagonal Only	R7-11-14	18 x 18	Rectangle	G/W



R7-11-1



R7-11-11

GENERAL GUIDELINES

1. Install signs at beginning and end of parking zone.
2. Signs with arrows should be installed below signs without arrows.
3. Angled Parking control signs should be installed below No Parking signs.

STANDARD APPLICATIONS

Location:	special zones
Distance from Property Line (0+00):	as noted in General Guidelines
Number of signs per Block Face:	2
Types of Poles:	dig, drill, light pole
Mounting Height:	between 7'0" and 10'-7"
Mounting:	center
Angle:	signs with arrow: 30 degrees; signs without arrow: 90 degrees
Sign Blank:	single-sided
Co-Mounting:	Can be mounted with other Regulatory Parking, Informational, and Non-Traffic signs.
Exception:	Does not apply
Note:	Does not apply

MUTCD FOOTNOTE: These guidelines are not intended to conflict in any way with either the USDOT Manual of Uniform Traffic Control Devices (MUTCD) or the IDOT Standard Highway Manual. In the event of any present or future conflict, the information provided in the MUTCD or IDOT Signs Manual takes precedence.



MUTCD

Part 2B: Regulatory Signs, Barricades, and Gates
Section 2B-46: Parking, Standing and Stopping Signs

ILLINOIS COMPILED STATUTES

Illinois Vehicle Code: (625 ILCS 5)
Section 11-208(a) 1: Powers of Local Authorities
Section 11-1304: Additional Parking Regulations

MUNICIPAL CODE OF CHICAGO

Chapter 9-64: Parking Regulations
Section 9-64-030: Diagonal Parking Zones

ORDINANCE REQUIREMENTS

Yes. Ordinance required for parking zones.

MUTCD FOOTNOTE: These guidelines are not intended to conflict in any way with either the USDOT Manual of Uniform Traffic Control Devices (MUTCD) or the IDOT Standard Highway Manual. In the event of any present or future conflict, the information provided in the MUTCD or IDOT Signs Manual takes precedence.



2.8 School Zones Series (R7)

Signs	Code	Size	Shape	Colors
1. No Parking (Symbol) School Days 7AM-4:30M RA TZ	R7-9-1	18 x 18	Rectangle	B-R/W, W/R
2. No Parking (Symbol) School Days 7AM-4:30PM LATZ	R7-9-3	18 x 18	Rectangle	B-R/W, W/R
3. No Parking (Symbol) School Days 7AM-4:30PM TZ	R7-9-4	18 x 18	Rectangle	B-R/W, W/R
4. No Parking (Symbol) School Days (Hours) RA	R7-9-21	18 x 18	Rectangle	B-R/W, W/R
5. No Parking (Symbol) School Days (Hours) LA	R7-9-23	18 x 18	Rectangle	B-R/W, W/R
6. No Parking (Symbol) School Days (Hours) TZ	R7-9-24	18 x 18	Rectangle	B-R/W, W/R
7. No Parking (Symbol) Except for Official School Personnel Parking Only. School Days (Hours) (Days)	Special	18 x 24	Rectangle	B-R/W, W/R



R7-9-1



R7-9-21



Special

GENERAL GUIDELINES

1. If restriction covers portion of block, use arrow signs at beginning and end of zone.
2. School Zone series signs should be installed above all other signs without Tow Zone restrictions.

STANDARD APPLICATIONS

Location:	special zones
Distance from Property Line (0+00):	300 ft. block face: 81 feet 600 ft. block face: 200 ft, 400 ft
Number of signs per Block Face:	300 ft. block face: 1; 600 ft. block face: 2
Types of Poles:	dig, drill, light pole
Mounting Height:	between 7'0" and 10'-7"
Mounting:	center
Angle:	signs with arrow: 30 degrees; signs without arrow: 90 degrees
Sign Blank:	single-sided
Co-Mounting:	Can be mounted with other Regulatory Parking, Informational, and Non-Traffic signs.
Exception:	Provide additional signs at 200 ft intervals on blocks longer than 600 ft <ul style="list-style-type: none"> • For Safe School Zone signs, see Section 4.6, Non-Traffic Sign Series. • For School Speed Limit and School Crossing signs, see Section 3.1, School Zone Series. • Distance and number of signs per block apply to signs without arrows.
Note:	

MUTCD FOOTNOTE: These guidelines are not intended to conflict in any way with either the USDOT Manual of Uniform Traffic Control Devices (MUTCD) or the IDOT Standard Highway Manual. In the event of any present or future conflict, the information provided in the MUTCD or IDOT Signs Manual takes precedence.



MUTCD

Part 7B: Traffic Control for School Areas
Part 2B: Regulatory Signs, Barricades, and Gates
Section 2B-46: Parking, Standing and Stopping Signs

ILLINOIS COMPILED STATUTES

Illinois Vehicle Code: (625 ILCS 5)
Section 11-208(a) 2: Powers of Local Authorities

MUNICIPAL CODE OF CHICAGO

Chapter 9-64: Parking Regulations
Section 9-64-010: Applicability
Section 9-64-080: Parking Restricted on Certain Days or Hours

ORDINANCE REQUIREMENTS

Yes. Ordinance required for parking prohibition on school hours on school days.

MUTCD FOOTNOTE: These guidelines are not intended to conflict in any way with either the USDOT Manual of Uniform Traffic Control Devices (MUTCD) or the IDOT Standard Highway Manual. In the event of any present or future conflict, the information provided in the MUTCD or IDOT Signs Manual takes precedence.



2.9 Snow Route Series (R7)

Signs	Code	Size	Shape	Colors
1. Snowflake (Symbol) No Parking when Snow is Over 2 in. TZ	R7-210-1	18 x 18	Rectangle	W/B1/R/W, W/R
2. Snowflake (Symbol) No Parking 3AM-7AM Dec.1-Apr.1 or When Snow is Over 2in. Tow Zone	R7-210-2	18 x 24	Rectangle	W/B1/R/W, W/R



R7-210-1



R7-210-2

GENERAL GUIDELINES

- R7-210-1 and R7-210-2 signs should be installed to designated Snow Routes and Emergency Snow Routes respectively. Lists of routes are available from CDOT.
- Top of Snow Route sign should always be installed 10'-7" above the ground.
- Install signs on light pole whenever possible.
- Installation not required on streets with No Parking–Tow Zone signs.

STANDARD APPLICATIONS

Location:	midblock
Distance from Property Line (0+00):	300 ft. block face: 81 feet 600 ft. block face: 200 ft, 400 ft
Number of signs per Block Face:	300 ft. block face: 1; 600 ft. block face: 2
Types of Poles:	dig, drill, light pole
Mounting Height:	10'-7" to top of sign
Mounting:	center
Angle:	signs with arrow: 30 degrees; signs without arrow: 90 degrees
Sign Blank:	single-sided
Co-Mounting:	Can be mounted with other Regulatory Parking, Informational, and Non-Traffic signs.
Exception:	On blocks longer than 800 ft., install additional Snow Route signs at 200 ft. intervals
Note:	Does not apply

MUTCD FOOTNOTE: These guidelines are not intended to conflict in any way with either the USDOT Manual of Uniform Traffic Control Devices (MUTCD) or the IDOT Standard Highway Manual. In the event of any present or future conflict, the information provided in the MUTCD or IDOT Signs Manual takes precedence.



MUTCD

Part 2B: Regulatory Signs, Barricades, and Gates
Section 2B-46: Parking, Standing and Stopping Signs

ILLINOIS COMPILED STATUTES

Illinois Vehicle Code: (625 ILCS 5)
Section 11-208(a) 13: Powers of Local Authorities

MUNICIPAL CODE OF CHICAGO

Chapter 9-64: Parking Regulations
Section 9-64-060: Snow Removal

ORDINANCE REQUIREMENTS

No. Ordinance not required.

MUTCD FOOTNOTE: These guidelines are not intended to conflict in any way with either the USDOT Manual of Uniform Traffic Control Devices (MUTCD) or the IDOT Standard Highway Manual. In the event of any present or future conflict, the information provided in the MUTCD or IDOT Signs Manual takes precedence.



2.10 Street Cleaning Series (R7)

Signs	Code	Size	Shape	Colors
1. Street Cleaning No Parking (Hours), (Day of Week) (Dates)	R7-13-1	18 x 18	Rectangle	W/R, R/W
2. Street Cleaning No Parking 9am-3pm (no)(Day of Week) of Month (Dates)	R7-13-2	18 x 24	Rectangle	B-R/W, W/R



R7-13-1



R7-13-2

GENERAL GUIDELINES

1. Install signs on light poles when possible.
2. Street cleaning signs should be installed at 10'-7" unless they are placed on same pole as Snow Route signs.
3. Installation not required on streets with No Parking Tow Zone restrictions that cover entire block.

STANDARD APPLICATIONS

Location:	midblock
Distance from Property Line (0+00):	300 ft. block face: 81 feet 600 ft. block face: 200 ft, 400 ft
Number of signs per Block Face:	300 ft. block face: 1; 600 ft. block face: 2
Types of Poles:	dig, drill, light pole
Mounting Height:	10'-7" to top of sign
Mounting:	center
Angle:	signs with arrow: 30 degrees; signs without arrow: 90 degrees
Sign Blank:	single-sided
Co-Mounting:	Can be mounted with other Regulatory Parking, Informational, and Non-Traffic signs.
Exception:	On blocks longer than 800 ft., install additional signs at 200 ft. intervals
Note:	Does not apply

MUTCD

Part 2B: Regulatory Signs, Barricades, and Gates
Section 2B-46: Parking, Standing and Stopping Signs

ILLINOIS COMPILED STATUTES

Illinois Vehicle Code: (625 ILCS 5)

MUTCD FOOTNOTE: These guidelines are not intended to conflict in any way with either the USDOT Manual of Uniform Traffic Control Devices (MUTCD) or the IDOT Standard Highway Manual. In the event of any present or future conflict, the information provided in the MUTCD or IDOT Signs Manual takes precedence.



Section 208(a) 12: Powers of Local Authorities

MUNICIPAL CODE OF CHICAGO

Chapter 9-64: Parking Regulations

Section 9-64-040: Street Cleaning

ORDINANCE REQUIREMENTS

No. Ordinance not required.



3 WARNING SIGNS

3.1 School Zones Series (S1)

Signs	Code	Size	Shape	Colors
1. School (Symbol)	S1-1	30 x 30	Pentagon	B/Fluorescent GY
2. School Speed Limit 20 on School Days When Children Are Present	S4-1-100	24 x 48	Rectangle	B/Fluorescent GY,B/W
3. End of School Zone	S5-2	24 x 30	Rectangle	B/W



S4-1-100

GENERAL GUIDELINES:

1. Install School Speed Limit sign at beginning of reduced speed zone established by ordinance.
2. School advance signs should be placed 150ft. before intersection on streets with speed limits of 30 mp or lower. On streets with higher speed limits, signs are located based on standards provided in MUTCD.
3. School Crossing signs are to be located at the crosswalk or at the minimum distance in advance of crosswalk.

STANDARD APPLICATIONS

Location:	midblock or intersection
Distance from Property Line (0+00):	As noted in general guidelines
Number of signs per Block Face:	1
Types of Poles:	dig, drill, light pole
Mounting Height:	10'-7" to top of sign
Mounting:	center
Angle:	90 degrees
Sign Blank:	single-sided
Co-Mounting:	May be installed with other Warning Signs. Crossing and Advance Crossing signs may be installed with Supplemental signs, e.g. deaf.
Exception:	Does not apply
Note:	<ul style="list-style-type: none"> • For supplemental signs, see section 3.6, Crossing and Entry Sign Series.

MUTCD FOOTNOTE: These guidelines are not intended to conflict in any way with either the USDOT Manual of Uniform Traffic Control Devices (MUTCD) or the IDOT Standard Highway Manual. In the event of any present or future conflict, the information provided in the MUTCD or IDOT Signs Manual takes precedence.



- Sign S4-1-100 size may be reduced to 24x42.
-

MUTCD

Part 7B: Traffic Control for School Areas

Section 7B-08: School Signs and Plaques

Section 7B-9: School Zone Sign and Plaques and End School Zone Sign

Section 7B-11: School Advance Crossing Assembly

Section 7B-12: School Crossing Assembly

Section 7B-15: School Speed Limit Assembly and End School Speed Limit Sign

ILLINOIS COMPILED STATUTES

Illinois Vehicle Code (625 ILCS 5)

Section 11-208 (a) 2: Powers of Local Authorities

MUNICIPAL CODE OF CHICAGO

Chapter 9-8: Traffic Control Devices and Signals

Section 9-8-010: Authorized - Compliance required

ORDINANCE REQUIREMENTS

Yes. Ordinance required for School Speed Limit signs. Ordinance not required for School Advance and School Crossing.



3.2 Horizontal Alignment Series (W1)

Signs	Code	Size	Shape	Colors
1. Turn Sign–90 degree Left Arrow (Symbol)	W1-1L	30 x 30	Diamond	B/Y
2. Turn Sign–90 degree Right Arrow (Symbol)	W1-1R	30 x 30	Diamond	B/Y
3. Curve Sign–45 degree Left Arrow (Symbol)	W1-2L	30 x 30	Diamond	B/Y
4. Curve Sign–45 degree Left Arrow (Symbol)	W1-2R	30 x 30	Diamond	B/Y
5. Reverse Turn Sign–Left Turn First (Symbol)	W1-3L	30 x 30	Diamond	B/Y
6. Reverse Turn Sign–Right Turn First (Symbol)	W1-3R	30 x 30	Diamond	B/Y
7. Reverse Curve Sign–Left Curve First (Symbol)	W1-4L	30 x 30	Diamond	B/Y
8. Reverse Curve Sign–Right Curve First (Symbol)	W1-4R	30 x 30	Rectangle	B/Y
9. Large Left Arrow (Symbol)	W1-6L	48 x 24	Rectangle	B/Y
10. Large Right Arrow (Symbol)	W1-6R	48 x 24	Rectangle	B/Y
11. Large Double Arrow (Symbol)	W1-7	48 x 24	Rectangle	B/Y
12. Chevron Alignment, Left (Symbol)	W1-8L	18 x 24	Rectangle	B/Y
13. Chevron Alignment, Right (Symbol)	W1-8R	18 x 24	Rectangle	B/Y
14. Combination Horizontal Alignment Advisory (Turn)	W1-1A	30 x 30	Diamond	B/Y
15. Combination Horizontal Alignment Advisory (Curve)	W1-2A	30 x30	Diamond	B/Y

GENERAL GUIDELINES

1. Location of Turn, Curve, Reverse Turn, and Reverse Curve signs prior to intersection are based on speed limit and MUTCD guidelines.
2. When Turn sign or Reverse Turn sign is warranted, Large Arrow signs may be used on outside of turn.
3. Do not install on same pole as regulatory parking signs.

STANDARD APPLICATIONS

Location:	special zones
Distance from Property Line (0+00):	Determined based on speed limit and MUTCD guidelines
Number of signs per Block Face:	1
Types of Poles:	dig, drill, light pole
Mounting Height:	7'-0" clearance to bottom of sign
Mounting:	center
Angle:	90 degrees
Sign Blank:	single-sided
Co-Mounting:	May be installed with other Regulatory and Warning signs
Exception:	Does not apply
Note:	Does not apply

MUTCD

Part 2C: Warning Signs and Object Markers

MUTCD FOOTNOTE: These guidelines are not intended to conflict in any way with either the USDOT Manual of Uniform Traffic Control Devices (MUTCD) or the IDOT Standard Highway Manual. In the event of any present or future conflict, the information provided in the MUTCD or IDOT Signs Manual takes precedence.



Section 2C-07: Horizontal Alignment Signs
Section 2C-09: Chevron Alignment Sign
Section 2C-10: Combination Horizontal Alignment/Advisory Speed Signs
Section 2C-12: One-Direction Large Arrow Sign

ILLINOIS COMPILED STATUTES

Illinois Vehicle Code: (625 ILCS 5)
Section 11-208(a) 2,9: Powers of Local Authorities

MUNICIPAL CODE OF CHICAGO

Chapter 9-16: Turning movements
Section 9-16-010: Markings and Indicating Devices
Chapter 9-8: Traffic Control Devices
Section 9-8-010: Authorized - Compliance required

ORDINANCE REQUIREMENTS

No. Ordinance not required.



3.3 Advance Warning Series (W3)

Signs	Code	Size	Shape	Colors
1. Stop Ahead (Symbol)	W3-1	30 x 30	Diamond	B-W-R/Y
2. Signal Ahead (Symbol)	W3-3	30 x 30	Diamond	B-R-G/Y
3. Photo Enforced	W16-10	24 x 18	Rectangle	B/Y, B/W
4. Diagonal Arrow - Right	W16-7PR	24 x 12	Rectangle	B/Y
5. Diagonal Arrow - Left	W16-7PL	24 x 12	Rectangle	B/Y
6. Ahead	W16-9P	24 x 12	Rectangle	B/Y

GENERAL GUIDELINE

1. Installation and location of signs should be based on CDOT engineering study. Authorization by Field Service Supervisor or City Traffic Engineer required.
2. These signs are typically used at locations where construction or street geometry make the presence of a Stop sign or signal unexpected. They are also used on arterial street stops for a period of time, typically 90 days after initial installation, to advise motorists of the presence of a new Stop sign.

STANDARD APPLICATIONS

Location:	midblock
Distance from Property Line (0+00):	As specified by visibility study.
Number of signs per Block Face:	1
Types of Poles:	dig, drill, light pole
Mounting Height:	7'-0" clearance to bottom of sign
Mounting:	center
Angle:	90 degrees
Sign Blank:	single-sided
Co-Mounting:	May be installed with other Regulatory signs
Exception:	Does not apply
Note:	Does not apply

MUTCD

- Part 2C: Warning Signs and Object Markers
- Section 2C-36: Advance Traffic Control Signs
- Section 2C-50: Non-Vehicular Warning Signs
- Section 2C-53: Use of Supplemental Warning Plaques
- Section 2C-61: Photo Enforced Plaque

ILLINOIS COMPILED STATUTES

- Illinois Vehicle Code: (625 ILCS 5)
- Section 11-208(a) 2: Powers of Local Authorities

MUNICIPAL CODE OF CHICAGO

- Chapter 9-8: Traffic Control Devices
- Section 9-8-010: Authorized - Compliance required

MUTCD FOOTNOTE: These guidelines are not intended to conflict in any way with either the USDOT Manual of Uniform Traffic Control Devices (MUTCD) or the IDOT Standard Highway Manual. In the event of any present or future conflict, the information provided in the MUTCD or IDOT Signs Manual takes precedence.



ORDINANCE REQUIREMENTS

No. Ordinance not required.



3.4 Converging Traffic Series (W4,W6)

Signs	Code	Size	Shape	Colors
1. Merging Traffic From Left (Symbol)	W4-1L	30 x 30	Diamond	B/Y
2. Merging Traffic From Right (Symbol)	W4-1R	30 x 30	Diamond	B/Y
3. Pavement Width Transition (Symbol)	W4-2	30 x 30	Diamond	B/Y
4. Two Way Traffic (Symbol)	W6-3-1	30 x 30	Diamond	B/Y

GENERAL GUIDELINES

1. Installation and location of signs should be based on CDOT engineering and traffic study. Authorization by City Traffic Engineer is required.
2. Two way traffic signs are used where traffic on a one way street approaches and meets a two way traffic street, and are used where one way streets may have been converted to two way operation.
3. The sign is typically located on the far side of the intersection facing the one way approach on the opposite side of the intersection.

STANDARD APPLICATIONS

Location:	intersection, midblock
Distance from Property Line (0+00):	Determined based on engineering and traffic study
Number of signs per Block Face:	1
Types of Poles:	dig, drill, light pole
Mounting Height:	7'-0" clearance to bottom of sign
Mounting:	center
Angle:	90 degrees
Sign Blank:	single-sided
Co-Mounting:	May be installed with other Regulatory signs
Exception:	Does not apply
Note:	Does not apply

MUTCD

Part 2C: Warning Signs and Object Markers

Section 2C-40: Merge signs

Section 2C-42: Lane Ends signs

Section 2C-44: Two Way Traffic signs

ILLINOIS COMPILED STATUTES

Illinois Vehicle Code: (625 ILCS 5)

Section 11-208(a) 2: Powers of Local Authorities

MUNICIPAL CODE OF CHICAGO

Chapter 9-12: Traffic and Speed Restrictions

Section 9-12-050: Traffic Lanes

ORDINANCE REQUIREMENTS

No. Ordinance not required.



3.5 Road Conditions Series (W8)

Signs	Code	Size	Shape	Colors
1. Slippery When Wet (Symbol)	W8-5	30 x 30	Diamond	B/Y

GENERAL GUIDELINES

1. Sign installation should be limited to bridge structures unless authorized by a CDOT Traffic Engineer.
2. Signs should be located at beginning of slippery zone. If zone is over 400 feet intermediate signs should be provided at 400 ft. intervals.

STANDARD APPLICATIONS

Location:	special zones
Distance from Property Line (0+00):	As outlined in General Guidelines
Number of signs per Block Face:	1
Types of Poles:	dig, drill, light pole
Mounting Height:	7'-0" clearance to bottom of sign
Mounting:	center
Angle:	90 degrees
Sign Blank:	single-sided
Co-Mounting:	May be installed with other Regulatory signs
Exception:	Does not apply
Note:	This sign is installed on bridges.

MUTCD

Part 2C: Warning Signs and Object Markers

Section 2C- 32: Surface Condition Signs

ILLINOIS COMPILED STATUTES

Illinois Vehicle Code: (625 ILCS 5)

Section 11-208(a) 2: Powers of Local Authorities

MUNICIPAL CODE OF CHICAGO

Chapter 9-8: Traffic Control Devices and Signals

Section 9-8-010: Authorize

ORDINANCE REQUIREMENTS

No. Ordinance not required.



3.6 Crossing And Entry Signs Series (W10, W11)

Signs	Code	Size	Shape	Colors
1. Railroad Advance Warning (Symbol)	W10-1	36 x 36	Circular	B/Fluorescent GY
2. Bicycle Warning (Symbol)	W11-1	30 x 30	Diamond	B/Fluorescent GY
3. Pedestrian (Symbol)	W11-2	30 x 30	Diamond	B/Fluorescent GY
4. Blind	W11-2-3	18 x 24	Rectangle	B/Fluorescent GY
5. Deaf	W11-2-4	18 x 24	Rectangle	B/Fluorescent GY
6. Blind & Deaf	W11-2-5	18 x 24	Rectangle	B/Fluorescent GY
7. Senior Citizens	W11-2-6	18 x 24	Rectangle	B/Fluorescent GY
8. Accessible	W11-9	30 x 30	Diamond	B/Fluorescent GY
9. Ahead	W16-9P	10 x 30	Rectangle	B/Fluorescent GY



W11-2-3



W11-2-4



W11-2-5



W11-2-6

GENERAL GUIDELINES

1. Advance crossing signs should be located based on vehicle speeds and MUTCD guidelines.
2. Crossing signs shall be located immediately adjacent to crossing location.
3. Only one set Advance Warning and Crossing signs should be installed per location.
4. Signs #4-#7 are not MUTCD-compliant and not enforceable. These signs may only be installed for a dedicated/exclusive facility and with the approval of a traffic engineering study.

STANDARD APPLICATIONS

Location:	midblock
Distance from Property Line (0+00):	To be determined based on limit and MUTCD guidelines
Number of signs per Block Face:	1
Types of Poles:	dig, drill, light pole
Mounting Height:	7'-0" clearance to bottom of sign
Mounting:	center
Angle:	90 degrees
Sign Blank:	single-sided
Co-Mounting:	Supplemental signs #5-#9 are mounted only in combination with Crossing, Advance Crossing, and School Crossing signs.
Exception:	Does not apply

MUTCD FOOTNOTE: These guidelines are not intended to conflict in any way with either the USDOT Manual of Uniform Traffic Control Devices (MUTCD) or the IDOT Standard Highway Manual. In the event of any present or future conflict, the information provided in the MUTCD or IDOT Signs Manual takes precedence.



Note: For School Crossing signs, see 3.1, School Zone Series.

MUTCD

Part 2C: Warning Signs and Object Markers
Section 2C-49: Vehicular Traffic signs
Section 2C-50: Non-vehicular signs
Part 8B: Traffic Control for Railroad and Light Rail Transit Grade Crossings
Section 8B-6: Grade Crossing Advance Warning Signs

ILLINOIS COMPILED STATUTES

Illinois Vehicle Code: (625 ILCS 5)
Section 11-208(a) 2,8,12: Powers of Local Authorities

MUNICIPAL CODE OF CHICAGO

Chapter 9-8: Traffic Control Devices and Signals
Section 9-8-010: Authorized - Compliance required

ORDINANCE REQUIREMENTS

No. Ordinance not required.

MUTCD FOOTNOTE: These guidelines are not intended to conflict in any way with either the USDOT Manual of Uniform Traffic Control Devices (MUTCD) or the IDOT Standard Highway Manual. In the event of any present or future conflict, the information provided in the MUTCD or IDOT Signs Manual takes precedence.



3.7 Entrances Series (W11)

Signs	Code	Size	Shape	Colors
1. Truck Entrance (Symbol)	W11-10	30 x 30	Diamond	B/Y
2. Fire Station (Symbol)	W11-8	30 x 30	Diamond	B/Y

GENERAL GUIDELINES

1. Advance entrance signs should be located based on vehicle speeds and MUTCD guidelines.
2. Entrance signs shall be located immediately adjacent to crossing location.
3. Only one set advance entrance signs should be installed per approach.

STANDARD APPLICATIONS

Location:	special zones
Distance from Property Line (0+00):	Based on speed limit and MUTCD guidelines.
Number of signs per Block Face:	1
Types of Poles:	dig, drill, light pole
Mounting Height:	7'-0" clearance to bottom of sign
Mounting:	center
Angle:	90 degrees
Sign Blank:	single-sided
Co-Mounting:	None
Exception:	Does not apply
Note:	Does not apply

MUTCD

Part 2C: Warning Signs and Object Markers
Section 2C-49: Vehicular Traffic signs

ILLINOIS COMPILED STATUTES

Illinois Vehicle Code: (625 ILCS 5)
Section 11-208(a) 2: Powers of Local Authorities

MUNICIPAL CODE OF CHICAGO

Chapter 9-8: Traffic Control Devices and Signals
Section 9-8-010: Authorized - Compliance required

ORDINANCE REQUIREMENTS

No. Ordinance not required.



3.8 Vertical Clearance (W12)

Signs	Code	Size	Shape	Colors
1. Double Arrows (Variable Height)	W12-2	36 x 36	Diamond	B/Y
2. Right Turn Vertical Clearance (Height)	W12-2-1	30 x 30	Rectangle	B/Y
3. Left Turn Vertical Clearance (Height)	W12-2-3	30 x 30	Rectangle	B/Y



W12-2



W12-2-1



W12-2-3

GENERAL GUIDELINES

1. Install W12-2 sign whenever clearance is less than or equal to 14'-6".
2. Clearance should be provided in 2" increments with a minimum of 1" inch above actual height.
3. Clearance height must be re-measured after roadway construction or resurfacing projects.
4. W12-2 signs must be located so that approaching vehicles can legally turn and avoid the structure.

STANDARD APPLICATIONS

Location:	intersection, midblock
Distance from Property Line (0+00):	As noted in General Guidelines
Number of signs per Block Face:	1
Types of Poles:	dig, drill, light pole for W12-2; (Variable Height) signs are mounted on structure, traffic signal mast arm
Mounting Height:	7'-0" clearance to bottom of sign
Mounting:	center
Angle:	90 degrees
Sign Blank:	single-sided
Co-Mounting:	May be installed with other Regulatory Warning signs
Exception:	Does not apply
Note:	Variable Height signs are on bridge structures

MUTCD FOOTNOTE: These guidelines are not intended to conflict in any way with either the USDOT Manual of Uniform Traffic Control Devices (MUTCD) or the IDOT Standard Highway Manual. In the event of any present or future conflict, the information provided in the MUTCD or IDOT Signs Manual takes precedence.



MUTCD

Part 2C: Warning Signs and Object Markers
Section 2C-27: Low Clearance signs

ILLINOIS COMPILED STATUTES

Illinois Vehicle Code: (625 ILCS 5)
Section 11-208(a) 2,4,10: Powers of Local Authorities

MUNICIPAL CODE OF CHICAGO

Chapter 9-8: Traffic Control Devices and Signals
Section 9-8-010: Authorized - Compliance required

ORDINANCE REQUIREMENTS

No. Ordinance not required.



3.9 Supplemental Speed Series (W13)

Signs	Code	Size	Shape	Colors
1. Advisory speed plate — MPH	W13-1-1	18 x 18	Rectangle	B/W, Y/B
2. Advisory speed plate — MPH	W13-1-2	24 x 24	Rectangle	B/W, Y/B

GENERAL GUIDELINES

1. Advisory speed plates should be used to supplement other signs, e.g. curve or turn signs.
2. 18x18 signs are used with warning signs that are 30" and under. 24x24 speed signs are used with warning signs that are
3. 36" and over.

STANDARD APPLICATIONS

Location:	intersection, midblock
Distance from Property Line (0+00):	Based on location of warning signs being supplemented
Number of signs per Block Face:	1
Types of Poles:	dig, drill, light pole
Mounting Height:	7'-0" clearance to bottom of sign
Mounting:	center
Angle:	90 degrees
Sign Blank:	single-sided
Co-Mounting:	Must be installed to supplement Horizontal Alignment Warning signs.
Exception:	Does not apply
Note:	For Horizontal Alignment, see Section 3.2, Horizontal Alignment Series.

MUTCD

Part 2C: Warning Signs and Object Markers
 Section 2C-08: Advisory Speed Plaque

ILLINOIS COMPILED STATUTES

Illinois Vehicle Code: (625 ILCS 5)
 Section 11-208(a) 2,4,10: Powers of Local Authorities

MUNICIPAL CODE OF CHICAGO

Chapter 9-8: Traffic control devices and signals
 Section 9-8-010: Authorized - Compliance required

ORDINANCE REQUIREMENTS

No. Ordinance not required.

MUTCD FOOTNOTE: These guidelines are not intended to conflict in any way with either the USDOT Manual of Uniform Traffic Control Devices (MUTCD) or the IDOT Standard Highway Manual. In the event of any present or future conflict, the information provided in the MUTCD or IDOT Signs Manual takes precedence.



3.10 Road Cross-Section Series (W14)

Signs	Code	Size	Shape	Colors
1. Dead End	W14-1	30 x 30	Diamond	B/Y
2. No Outlet	W14-2	30 x 30	Diamond	B/Y
3. No Outlet Pointing Right	W14-2PR	36 x 9	Rectangle	B/Y
4. No Outlet Pointing Left	W14-2PL	36 x 9	Rectangle	B/Y



W14-2PR

GENERAL GUIDELINES

1. No Outlet signs may be installed at streets that end in either a cul-de-sac or dead end.
2. Signs should be installed so that approaching vehicles can turn and avoid the dead end or cul-de-sac.

STANDARD APPLICATIONS

Location:	intersection
Distance from Property Line (0+00):	Based on Traffic Engineering study
Number of signs per Block Face:	2
Types of Poles:	dig, drill, light pole
Mounting Height:	7'-0" clearance to bottom of sign
Mounting:	center mounted; flag mount for W14-2PR and W14-2PL signs
Angle:	90 degrees
Sign Blank:	single-sided; double-sided for W14-2PR and W14-2PL signs
Co-Mounting:	May be mounted with other intersection Regulatory and Warning Signs.
Exception:	Does not apply
Note:	For Cul-de-Sac and Traffic Circle signs, see Section 3.11, Traffic Calming Series.

MUTCD

Part 2C: Warning Signs and Object Markers
Section 2C-26: Dead End/No Outlet Signs

ILLINOIS COMPILED STATUTES

Illinois Vehicle Code: (625 ILCS 5)
Section 11-208(a) 2,4,10: Powers of Local Authorities

MUNICIPAL CODE OF CHICAGO

Chapter 9-8: Traffic Control Devices and Signals
Section 9-8-010: Authorized - Compliance required

ORDINANCE REQUIREMENTS

No. Ordinance not required.

MUTCD FOOTNOTE: These guidelines are not intended to conflict in any way with either the USDOT Manual of Uniform Traffic Control Devices (MUTCD) or the IDOT Standard Highway Manual. In the event of any present or future conflict, the information provided in the MUTCD or IDOT Signs Manual takes precedence.



3.11 Traffic Calming Series

Signs	Code	Size	Shape	Colors
1. Traffic Circle (Symbol)	W2-6	24x24	Diamond	B/Y
2. Traffic Circle (Reflectors)	OM1-2	18x18	Diamond	B/Y Fluorescent
3. Cul-De-Sac No Outlet (Symbol)	W14-2C	24x24	Diamond	B/Y
4. Speed Hump (Street)	W17-1	30x30	Diamond	B/Y
5. Speed Hump (Alley)	W17-1A	24x24	Diamond	B/Y
6. Cul-de-Sac (Reflectors)	OM4-2	18x18	Diamond	B/R Fluorescent

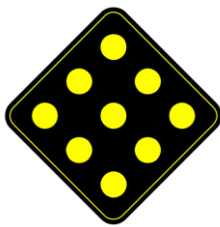

OM1-2

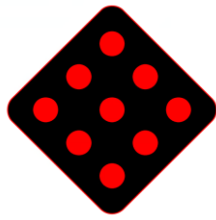

OM4-2



W14-2C

GENERAL GUIDELINES

1. Refer to standard drawings prepared by CDOT for location and layout of traffic calming signs and required pavement marking.
2. Refer to Commonly Used Signs: Fabrication Detail for OM1-2 and OM4-2.

STANDARD APPLICATIONS

Location:	intersection, midblock
Distance from Property Line (0+00):	As shown in standard drawings
Number of signs per Block Face:	1
Types of Poles:	dig, drill
Mounting Height:	7'-0" clearance to bottom of sign for W series; 4'-0" clearance to bottom of sign for OM series
Mounting:	center mounted
Angle:	90 degrees
Sign Blank:	single-sided
Co-Mounting:	See CDOT Standard Traffic Calming standards for typical co-mounting combinations
Exception:	Does not apply
Note:	Does not apply

MUTCD

Part 2C: Warning Signs and Object Markers
Section 2C-29: Speed Hump Sign

MUTCD FOOTNOTE: These guidelines are not intended to conflict in any way with either the USDOT Manual of Uniform Traffic Control Devices (MUTCD) or the IDOT Standard Highway Manual. In the event of any present or future conflict, the information provided in the MUTCD or IDOT Signs Manual takes precedence.



Section 2C-46: Intersection Warning Signs
Section 2C-63: Object Marker Design and Placement Height
Section 2C-66: Object Markers for Ends of Roadways

ILLINOIS COMPILED STATUTES

Illinois Vehicle Code: (625ILCS 5)
Section: 11-208 (a): Powers of Local Authorities

MUNICIPAL CODE OF CHICAGO

Chapter 9-8: Traffic Control Devices and Signals
Section 9-8-010: Authorized - Compliance required

ORDINANCE REQUIREMENTS

No. Ordinance not required.



4 GUIDE SIGNS

4.1 Street Name Signs Series (D3)

Signs	Code	Size	Shape	Colors
1. Street Name Sign	D3-1	Varies x 6 3/4	Rectangle	W/Green
2. Street Name Sign for Signal Mast Arm	D3-2	Varies x 18 or 24	Rectangle	W/Green
3. Honorary Street Name Sign	D3-3	Varies x 6 3/4	Rectangle	W/Brown



D3-1



D3-2



D3-3

GENERAL GUIDELINES

1. Street name signs should be visible to both pedestrians and vehicles.
2. Mast arm signs are recommended at all signalized intersections.
3. D3-1 Street Name signs should not be installed at the same intersection where D3-2 Street Name signs are installed.
4. Location of signs on traffic signal poles should follow typical layout included in exhibit *Regulatory Sign Installation on Traffic Signals*.
5. The N-S street name sign should be installed above the E-W sign.
6. Refer to exhibit *CDOT Street Name Sign Standard_20190716* for additional Street Name sign standards.
7. When used on arterial streets, D3-1 signs should be installed on the far-right corner of each approach.
8. D3-3 signs should be installed under D3-1 signs identifying actual street name.
9. Refer to Commonly Used Signs: Fabrication Detail for D3-1 and D3-2.

STANDARD APPLICATIONS

Location:	intersection, midblock
Distance from Property Line (0+00):	0 ft.
Number of signs per Block Face:	1
Types of Poles:	dig, drill, light pole, mast arm
Mounting Height:	9'-0" clearance to bottom of sign on dig or drill post; 11'-8" clearance to bottom of sign on light pole
Mounting:	flag (D3-1 or D3-3); mast arm (D3-2)
Angle:	90 degrees
Sign Blank:	double-sided for D3-1 & D3-3; single-sided for D3-2

MUTCD FOOTNOTE: These guidelines are not intended to conflict in any way with either the USDOT Manual of Uniform Traffic Control Devices (MUTCD) or the IDOT Standard Highway Manual. In the event of any present or future conflict, the information provided in the MUTCD or IDOT Signs Manual takes precedence.



Co-Mounting:	Honorary street name signs should be mounted with standard D3-1 signs. Street name signs may be mounted with other intersection Regulatory signs.
Exception:	D3-1 and D3-3 signs may be moved from far-right corner to near-right to avoid installation of an additional sign pole.
Note:	Does not apply

MUTCD

Part 2D: Guide Signs – Conventional Roads
Section 2D-43: Street Name Sign

ILLINOIS COMPILED STATUTES

Illinois Vehicle Code: (625ILCS 5)
Section 11-80-19: Naming of Streets

MUNICIPAL CODE OF CHICAGO

Chapter 10-4: Arrangement of City Streets
Section 10-4-010: Street Name and Signs
Honorary street name sign ordinance was passed on December 3, 1984 (C.J.P. 11459-60)

ORDINANCE REQUIREMENTS

Yes. Ordinance required for Honorary signs. Ordinance not required for Street Name signs



4.2 Parking Series (D4)

Signs	Code	Size	Shape	Colors
1. Parking with Arrow	D4-1	30 x 24	Rectangle	G/W



D4-1

GENERAL GUIDELINES

1. Signs should be used to show direction to nearby parking areas that are not visible to anyone.
2. 30x24 signs should only be located on arterial streets.
3. Signs should not be used more than three blocks from parking area.

STANDARD APPLICATIONS

Location:	Intersection
Distance from Property Line (0+00):	0 ft – 100 ft.
Number of signs per Block Face:	1
Types of Poles:	dig, drill, light pole
Mounting Height:	7'-0" clearance to bottom of sign
Mounting:	Center
Angle:	90 degrees
Sign Blank:	Single-sided
Co-Mounting:	No
Exception:	Does not apply
Note:	Private parking signs should not be installed within City right-of-way.

MUTCD

Part 2D: Guide Signs – Conventional Roads
 Section 2D-40: Parking Area sign

ILLINOIS COMPILED STATUTES

Illinois Vehicle Code: (625ILCS 5)
 Section 11-208(a) 1: Powers of Local Authorities

MUNICIPAL CODE OF CHICAGO

Chapter 9-8: Traffic Control Devices and Signals
 Section 9-8-010: Authorized - Compliance required

ORDINANCE REQUIREMENTS

No. Ordinance not required.

MUTCD FOOTNOTE: These guidelines are not intended to conflict in any way with either the USDOT Manual of Uniform Traffic Control Devices (MUTCD) or the IDOT Standard Highway Manual. In the event of any present or future conflict, the information provided in the MUTCD or IDOT Signs Manual takes precedence.



4.3 General Service Series (D9)

Signs	Code	Size	Shape	Colors
1. H (Hospital Symbol)	D9-2	24 x 24	Rectangle	W/Blue
2. Trauma Center	D9-2-1	24 x 12	Rectangle	W/Blue
3. # Blocks	D9-2-2	24 x 6	Rectangle	W/Blue
4. Directional Arrow (L/R)	D9-2-3	21 x 15	Rectangle	W/Blue
5. Directional Arrow (Diagonal)	D9-2-4	21 x 15	Rectangle	W/Blue
6. Directional Arrow (Up)	D9-2-5	21 x 15	Rectangle	W/Blue



D9-2-1



D9-2-2



D9-2-3



D9-2-4



D9-2-5

GENERAL GUIDELINES

1. Signs should be used to direct vehicles to hospitals/trauma centers not visible to drivers.
2. Blocks and direction arrow signs may be mounted under primary signs to provide additional information.
3. Signs should not be overlapping.

STANDARD APPLICATIONS

Location:	Special zone
Distance from Property Line (0+00):	varies
Number of signs per Block Face:	1
Types of Poles:	dig, drill, light pole
Mounting Height:	7'-0" clearance to bottom of sign
Mounting:	Center
Angle:	90 degrees
Sign Blank:	Single-sided
Co-Mounting:	Signs #3 - #6 shall only be installed to supplement signs #1 and #2.
Exception:	Does not apply
Note:	Does not apply

MUTCD

Part 2I: General Service Signs

Section 2I-02: General Service Signs for Conventional Roads

ILLINOIS COMPILED STATUTES

Illinois Vehicle Code: (625ILCS 5)

Section 11-208(a) 1: Powers of Local Authorities

MUTCD FOOTNOTE: These guidelines are not intended to conflict in any way with either the USDOT Manual of Uniform Traffic Control Devices (MUTCD) or the IDOT Standard Highway Manual. In the event of any present or future conflict, the information provided in the MUTCD or IDOT Signs Manual takes precedence.



MUNICIPAL CODE OF CHICAGO

Chapter 9-8: Traffic Control Devices and Signals

Section 9-8-010: Authorized - Compliance required

ORDINANCE REQUIREMENTS

No. Ordinance not required.



4.4 Bicycling Series

Signs	Code	Size	Shape	Colors
1. Bike Route	D11-1	24 x 18	Rectangle	W/G
2. Bike Destination Guide (Symbol)	D11-1C	24 x 18	Rectangle	W/G
3. Route Sign Supplemental Plaque (Arrow)	M7-1...7	12 x 9	Rectangle	W/G
4. Bike Destination Guide (w/o Mileage)	D1-1B	Varies x 6	Rectangle	W/G
5. Bike Destination Guide (w/ Mileage)	D1-1C	Varies x 6	Rectangle	W/G
6. Bike Destination Guide (2 lines)	D1-2C	Varies x 12	Rectangle	W/G
7. Bike Destination Guide (3 lines)	D1-3C	Varies x 18	Rectangle	W/G
8. Bike Lane	R3-17	30 x 24	Rectangle	B/W
9. Bike Lane Supplemental Plaque (Ahead)	R3-17AP	30 x 12	Rectangle	B/W
10. Bike Lane Supplemental Plaque (End)	R3-17BP	30 x 12	Rectangle	B/W
11. Except Bikes	R3-7BP Special	Variable x 9; Variable x18	Rectangle	B/W
12. Shared Lane, Yield to Bikes	W11-1A	30 x 30	Diamond	B/Fluorescent Y-G
13. Begin Right Turn Lane Yield to Bikes	R4-4	36 x 30	Rectangle	B/W
14. Right Turn Only (Except Bike)	R3-5 Special	30 x 36	Rectangle	B/W
15. Right Turn Only (Except Bike/Bus)	R3-5 Special	30 x 36	Rectangle	B/W
16. Bike/Bus Lane	Special	30 x 42	Rectangle	B/W
17. Bicycle Wrong Way	R5-1B	12 x 18	Rectangle	W/R
18. Bikes May Use Ped Signal	R9-5 MOD	12 x 18	Rectangle	B/W
19. Bikes Use Ped Signal	R9-5 MOD	12 x 18	Rectangle	B/W



D11-1C

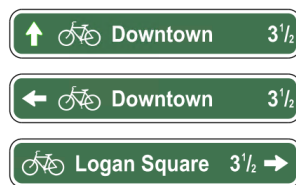

D1-1C



D1-2C

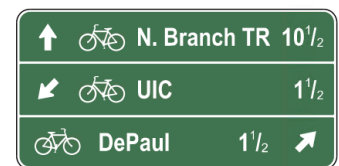

D1-3C



R3-5 Special



R3-5 Special



R3-7BP Special



W11-1A

MUTCD FOOTNOTE: These guidelines are not intended to conflict in any way with either the USDOT Manual of Uniform Traffic Control Devices (MUTCD) or the IDOT Standard Highway Manual. In the event of any present or future conflict, the information provided in the MUTCD or IDOT Signs Manual takes precedence.



Special



R9-5 MOD

GENERAL GUIDELINES

1. Installation and location of signs should be coordinated with CDOT’s Bicycle Coordinator.
2. R3-7bP (Special) plaques should be added to existing signs as necessary and match the width of the existing sign and should be coordinated with CDOT’s Bicycle Coordinator.

STANDARD APPLICATIONS

Location:	Intersection, midblock
Distance from Property Line (0+00):	varies
Number of signs per Block Face:	1
Types of Poles:	dig, drill, light pole
Mounting Height:	7’-0” clearance to bottom of sign
Mounting:	Center
Angle:	90 degrees
Sign Blank:	Single-sided
Co-Mounting:	May be mounted with other regulatory traffic signs.
Exception:	<ol style="list-style-type: none"> 1. When used, Signs #9 and #10 shall be mounted with Sign #8. 2. When used, Sign #3 should be mounted directly below Sign #2. 3. Sign #17 may be mounted back-to-back with other signs or mounted at 180 degrees (ie. Facing the wrong-way bicycle traffic, such as on the left side of a roadway).
Note:	<ul style="list-style-type: none"> • For Bicycle Warning Sign (W11-1), see Section 3.6, Crossing and Entry Signs Series. • For No Bicycle signs, see Section 1.3.3, Exclusion.

MUTCD

- Part 9B: Traffic Control for Bicycle Facilities
- Section 9B-04: Bicycle Lane Signs and Plaques
- Section 9B-05: Begin Right Turn Lane Yield to Bikes sign
- Section 9B-07: Bicycle Wrong Way and Ride with Traffic Plaque
- Section 9B-20: Bicycle Guide signs
- Section 9B-21: Destination Arrow and Supplemental Plaque signs for Bicycle Route signs
- Section 9B-22: Bicycle Parking Area sign

ILLINOIS COMPILED STATUTES

- Illinois Vehicle Code: (625ILCS 5)
- Section 11-208(a) 1: Powers of Local Authorities

MUTCD FOOTNOTE: These guidelines are not intended to conflict in any way with either the USDOT Manual of Uniform Traffic Control Devices (MUTCD) or the IDOT Standard Highway Manual. In the event of any present or future conflict, the information provided in the MUTCD or IDOT Signs Manual takes precedence.



MUNICIPAL CODE OF CHICAGO

Chapter 9-8: Traffic Control Devices and Signals

Section 9-8-010: Authorized - Compliance required

ORDINANCE REQUIREMENTS

No. Ordinance not required.



4.5 Transportation Series

Signs	Code	Size	Shape	Colors
1. (Symbol) Taxi Stand (No.) Taxis Here RA	T2-2-1	18 x 18	Rectangle	B/Y, B/W
2. (Symbol) Taxi Stand (No.) Taxis Here LA	T2-2-3	18 x 18	Rectangle	B/Y, B/W
3. (Symbol) Taxi Stand (No.) Taxis Here	T2-2-4	18 x 18	Rectangle	B/Y, B/W



T2-2-1

GENERAL GUIDELINES

1. Taxi stand signs are installed at the beginning of the zone established.

STANDARD APPLICATIONS

Location:	Special zone
Distance from Property Line (0+00):	As specified by zone
Number of signs per Block Face:	1
Types of Poles:	dig, drill, light pole
Mounting Height:	7'-0" clearance to bottom of sign
Mounting:	Center
Angle:	90 degrees
Sign Blank:	Single-sided
Co-Mounting:	NA
Exception:	Does not apply
Note:	Does not apply

MUTCD

MUTCD does not provide specific guidelines for these signs.

ILLINOIS COMPILED STATUTES

Illinois Vehicle Code: (625ILCS 5)

Section 11-208(a) 1: Powers of Local Authorities

MUNICIPAL CODE OF CHICAGO

Chapter 9-64: Parking Regulations

Section 9-64-140: Common Carrier Vehicle Stops and Stands

ORDINANCE REQUIREMENTS

Yes. Ordinance required for taxi stand.

MUTCD FOOTNOTE: These guidelines are not intended to conflict in any way with either the USDOT Manual of Uniform Traffic Control Devices (MUTCD) or the IDOT Standard Highway Manual. In the event of any present or future conflict, the information provided in the MUTCD or IDOT Signs Manual takes precedence.



4.6 Non-traffic Sign Series

Signs	Code	Size	Shape	Colors
1. Safe School Zone	SS-1	18 x 24	Rectangle	B/Y
2. No Peddling (Symbol)	SS-3	18 x 18	Rectangle	R-B/W



SS-1

GENERAL GUIDELINES

1. Signs are installed when requested by Aldermen. Safe School signs may be installed when requested by the school principal.
2. No Peddling sign requires ordinance prior to installation.
3. Only one sign should be installed per block regardless of length.

STANDARD APPLICATIONS

Location:	midblock
Distance from Property Line (0+00):	varies
Number of signs per Block Face:	1
Types of Poles:	dig, drill, light pole
Mounting Height:	7'-0" clearance to bottom of sign
Mounting:	Center
Angle:	90 degrees
Sign Blank:	Single-sided
Co-Mounting:	Can be mounted on same pole as other Regulatory Parking signs.
Exception:	Does not apply
Note:	Does not apply

MUTCD

MUTCD does not provide specific guidelines for these signs.

ILLINOIS COMPILED STATUTES

Illinois Vehicle Code: (625ILCS 5)

Section 11-208(a) 1: Powers of Local Authorities

MUNICIPAL CODE OF CHICAGO

Chapter 9-80: Miscellaneous Rules

Section 9-80-13: Cruising Zones

Chapter 2-102: Department of Transportation

MUTCD FOOTNOTE: These guidelines are not intended to conflict in any way with either the USDOT Manual of Uniform Traffic Control Devices (MUTCD) or the IDOT Standard Highway Manual. In the event of any present or future conflict, the information provided in the MUTCD or IDOT Signs Manual takes precedence.



Section 2-102-030(e): Commissioner – Powers and Duties

ORDINANCE REQUIREMENTS

Yes. Ordinance required for No Peddling.



5 Pay to Park (LAZ) signs

Chicago Parking Meters, LLC is the official operator of the City of Chicago’s 36,000 on-street parking spaces. LAZ Parking is responsible for collecting and maintaining the meters. The example signs shown below are used to indicate on-street parking spaces. However, these signs are not fabricated, owned, or maintained by CDOT. Sign plans should code these signs as “Special”.

Please contact Vegiovanni Dardovski (vegiiovanni.dardovski@cityofchicago.org) from the Department of Finance for LAZ sign installation details.

Examples of LAZ Pay to Park Signs



MUTCD FOOTNOTE: These guidelines are not intended to conflict in any way with either the USDOT Manual of Uniform Traffic Control Devices (MUTCD) or the IDOT Standard Highway Manual. In the event of any present or future conflict, the information provided in the MUTCD or IDOT Signs Manual takes precedence.



6 Commonly Used Signs: Fabrication Details

Stop	R1-1 (30")	Background 3930 High Intensity Prismatic Silk Screened 8831 Red Font Size: 10" Clear coated with 1160A GPS
	R1-1-2 (36")	Background 3930 High Intensity Prismatic Silk Screened 8831 Red Font Size: 12" Clear coated with 1160A GPS
One-Way	R6-2L/R	Background 3930 High Intensity Prismatic Silkscreened 8851 Black Font Size: 5" Clear coated with 1160A GPS
Do Not Enter	R5-1	Background 3930 High Intensity Prismatic Silk Screened 8831 Red Font size: 4" Clear coated with 1160A GPS
Street Name Sign	D3-1 & D3-2	Background 3930 High Intensity Prismatic Hand-cut 1177C green overlay film Font size 4" upper and lower case (4.25 when allowed)
Traffic Circle	OM1-2	Background 4081 Fluorescent Yellow Diamond Grade Silk Screened 8851 Black
Cul-de-Sac	OM4-2	Background 3992 Red VIP Silk Screened 8851 Black



SUMMARY OF SIGN CLASSIFICATION

The MUTCD lists five classification codes for signs, they are organized according to the type of regulation conveyed. Below are brief descriptions of the classifications:

- Regulatory Traffic Control Signs
- Regulatory Parking Signs
- School Signs/Warning Signs
- Guide signs
- Special Signs

Regulatory Traffic Signs

Regulatory signs convey information about a specific traffic regulation with which drivers must comply.

Right of Way Series – The Right of Way Series includes signs that assign the right of way to selected legs of an at grade intersection.

- **Stop Signs** – They are intended for use where traffic is required to stop. Because the stop sign causes a substantial inconvenience to the motorist, it should only be used where warranted.
- **Yield Signs** – They assign right of way to traffic on certain approaches to an intersection. Vehicles controlled by a yield sign need to stop only when necessary to avoid interference with other traffic that is given the right of way.

Speed Series – The speed series includes a variety of speed signs that may be used to post legal speed limits. These include the typical speed limit sign, truck, night, and minimum speed sign, as well as signs altering divers to changes in speed regulations.

Movement Series – The movement series contains a wide variety of signs affecting specific vehicle maneuvers. These include turn prohibition signs, signs related to roadway alignment and required vehicle maneuvers, exclusion signs and one way street signs.

- **Turning Signs** – They include turn prohibition and lane use control signs. Turn prohibition signs are usually used as a last resort where signalization cannot be used to safely accommodate turns, and where opposed or un-signalized turns may be unduly hazardous.
- **Alignment Signs** – They include those referring to required and/or prohibited movements required by the roadway alignment. This series includes signs designating diamond (special use) lanes such as bus lanes or general occupancy vehicle lanes.
- **Exclusion Signs** – They denote specific vehicles, pedestrians, and/or bicycles excluded from using a particular facility or portion of a facility.
- **One Way Signs** – They include the typical one way arrows that must be posted at every junction where designated one way streets can be entered.

Pedestrian Series – The pedestrian series includes both legend and symbol signs prohibiting hitchhiking, and pedestrian prohibition signs, signs requiring pedestrians to use crosswalks, and a sign requiring pedestrians to walk on left facing traffic.

Traffic Signal Control Series – Traffic Signal Control signs are used to supplement traffic signals and are often necessary to instruct pedestrians and drivers. Signal control signs should be located adjacent to the signal face to which they apply.

Regulatory Parking Signs

Parking signs and other signs devoted to curb control cover a very wide variety of regulations. These signs are often very specific, as curb control can be reserved for a wide range of reasons. These include

MUTCD FOOTNOTE: These guidelines are not intended to conflict in any way with either the USDOT Manual of Uniform Traffic Control Devices (MUTCD) or the IDOT Standard Highway Manual. In the event of any present or future conflict, the information provided in the MUTCD or IDOT Signs Manual takes precedence.



loading zones, snow route, street cleaning, and school zone restrictions. Parking prohibitions may only apply to specific times which must be clearly denoted.

No Parking Series – The No Parking Series includes a variety of signs which restrict parking, standing, or stopping along the public roadway.

- **No Parking At All Times Signs** – They provide twenty-four hour, seven day restrictions on parking. In general, the signs apply to all vehicles, but can be used to restrict parking of trucks. These include a Tow Zone designation where illegally parked vehicles are subject to be towed.
- **No Parking Specific Hours** – No Parking Specific Hours signs inform motorists of part-time parking restrictions. They are most commonly used to provide additional travel lanes during rush hour or other periods of high traffic volumes.
- **No Parking Specific Events** – No Parking Specific Events are used to restrict parking in the residential and commercial areas around Wrigley Field, Comiskey Park, and the United Center during ball games or other events drawing large crowds.
- **Time Limit Series** – The time limit parking series includes signs used to inform motorists of restrictions on the length of time that parking is allowed in an area. These signs are used for both metered and un-metered parking spaces.
- **Permit Parking Series** – The permit parking series includes signs that inform motorists that parking in an area is restricted to local residents displaying a residential parking permit. They are used in residential areas that receive large volumes of non-local traffic from adjacent commercial developments.
- **No Parking Loading Zone Series** – The no parking loading zone series includes signs that inform motorists that parking in an area is restricted to short term loading and unloading activities. These signs provide a private benefit to and are generally located in front of the business that has requested them.
- **Bus & Taxi Zone Series** – The bus and taxi zone series includes signs which restrict parking in areas used as bus stops, charter bus stops & stands, or taxi stands.
- **Accessible Parking Series** – The accessible parking series includes signs which restrict parking to vehicles displaying accessible permits and/or license plates.
- **Angle Parking Series** – The angled parking series includes signs which inform motorists that parking in an area is restricted to either diagonal parking only or parallel parking only. These signs are used when the geometry of the parking space or curb does not clearly indicate which way vehicles should be parked.
- **School Zones Series** – The school zone series includes signs which inform the motorist of part-time restrictions on parking adjacent to schools.
- **Snow Route Series** – The snow route series includes signs which identify Snow Routes and Emergency Snow Routes through the City.
- **Street Cleaning** – The street cleaning series includes signs which inform motorists of the times and days when parking is not permitted to clear the roadway for street sweepers.

Warning Signs

Warning signs provide drivers with information on impending conditions that are or may be hazardous. Warning signs call attention to conditions that generally require additional vigilance, a decline in speed, or a maneuver on the part of the driver. While warning signs are valuable aids to the safe and efficient movement of traffic, overuse should be avoided. Warning signs are not placed where conditions are

MUTCD FOOTNOTE: These guidelines are not intended to conflict in any way with either the USDOT Manual of Uniform Traffic Control Devices (MUTCD) or the IDOT Standard Highway Manual. In the event of any present or future conflict, the information provided in the MUTCD or IDOT Signs Manual takes precedence.



apparent and easily discerned by the driver. Warning signs may be placed if any of the following conditions exist: changes in horizontal alignment, intersections, converging traffic lanes, narrow roadway, changes in highway design, changes in highway design, changes in grades, roadway surface conditions, railroad crossings, entrances and crossings and control devices (advance warning).

- **School Zone Series** – The school zone series includes signs which warn motorists of school crossings and provide reduced speed limits near schools.
- **Horizontal Alignment Series** – The horizontal alignment series includes signs which provide advance notice of changes in the horizontal alignment of the street.
- **Advance Warning Series** – The advance warning series includes signs which warn motorist about stop signs, signals or traffic circles that may not be visible because of the geometry of the roadway.
- **Converging Traffic Series** – The converging traffic series includes signs which warn motorists about merging traffic or two-way traffic.
- **Road Conditions Series** – The road conditions series consists of signs that warns motorists of slippery conditions on the roadway.
- **Crossing and Entry Signs Series** – The crossing and entry sign series includes signs that warn the motorists of crossings with other travel modes including pedestrians, bicycles and trains.
- **Entrances Series** – The entrances series includes signs that warn motorists of entrances that could be used by other vehicles.
- **Vertical Clearance Series** – The vertical clearance series includes signs that warn motorists of restricted height on viaducts.
- **Supplemental Speed Series** – The supplemental speed series includes signs used to supplement other warning signs and recommend reduced speed limits.
- **Road Cross Section Series** – The road cross section series includes signs that warn motorists that the street is ending.
- **Traffic Calming Series** – The traffic calming series includes signs that warn motorists of cul-de-sacs, speed humps and traffic circles.

Guide Signs

Guides signs are of utmost importance to users unfamiliar with a roadway system. They are critical to safety in many instances: nothing is more unsafe than a confused driver approaching an intersection or diverge area. Guide signs provide information to assist drivers in selecting appropriate routes to their desired destination. Types of guide signs include destination signs, route markers, mileposts, recreational and cultural interest, street names and bicycles.

Street Name Signs Series – The street name sign series includes signs used to notify motorists of the official or honorary names of streets within the City.

Parking Series – The parking series includes signs used to direct motorists to off-street parking areas.

General Service Series – The general service series includes signs used to direct motorists to hospitals and trauma centers.

Bicycling Series – The bicycling series includes signs used by bicyclists to navigate on city streets and to inform motorists of the locations of designated bike lanes and bike routes.

Transportation Series – The transportation series includes signs used to notify motorists and pedestrians of the locations of taxi stands.

MUTCD FOOTNOTE: These guidelines are not intended to conflict in any way with either the USDOT Manual of Uniform Traffic Control Devices (MUTCD) or the IDOT Standard Highway Manual. In the event of any present or future conflict, the information provided in the MUTCD or IDOT Signs Manual takes precedence.



Special Signs

Special Signs includes non-traffic signs that are not described in the MUTCD.

Non-Traffic Series – The non-traffic series includes signs that notify pedestrians of allowable activities within the public right of way.



SIGN GUIDELINES GLOSSARY

Sign Classification

Regulatory Traffic Control Signs (R1-R6 series) – Includes applicable traffic laws that regulate the flow of traffic on City streets.

Regulatory Parking Signs (R7 series) – Controls parking, standing, and stopping along City streets.

School Signs (S Series) and Warning Signs (W series) – Warns traffic of existing or potentially hazardous conditions along City streets.

Guides signs (D series) – Informs vehicle operators and pedestrians of their current location and directs them to points of interest.

Special Signs (SS series) – Includes non-traffic signs that are not described in the MUTCD.

Sign Specifications

Identifies the sign series and provides a list and description of each sign. Including the sign code, a description of the text and/or symbols on the sign, sign size, shape, and color.

Sign Code – Sign codes are a letter followed by a series of numbers. They identify the sign series and the message that appears on the sign. Each sign has its own code.

Sign – This is the text and/or symbols that appear on the sign. Information that provides additional detail but does not appear on the signs is shown in parentheses. Text that is optional is shown in brackets. Text that varies between signs is shown with a blank line that must be completed by the user.

Size – Gives the width and length of a sign. If a sign's shape is non-rectangular, the size represents the maximum width by the maximum length.

Shape – Identifies the shape of a sign. Sign shapes include rectangles, diamonds, octagons, and pentagons.

Color – Provides information on the background, letter and symbol colors. Color prior to the slash is the letter or symbol color. Color after the slash is the background color. The color abbreviations are W-White, R-Red, B-Black, Bl-Blue, Br-Brown, Y-Yellow, and G-Green.

Reflective – Reflective provides information on the use of reflective sheeting, ink and film for the sign background and text. The letter Y indicates that reflective materials are used to manufacture the signs. The letter N indicates that the sign material is not reflective.

General Guidelines

Includes information that should be followed when ordering and installing signs. Included is sign location (within a block), sign hierarchy and when a sign should be used. It also identifies when the design and installation of a specific sign must be based on traffic or engineering studies and/or needs authorization by the Department of Transportation.

Standard Applications

Location – Location of a sign within a block. Choices are generally intersection, mid-block, or within a special zone.

Distance from Property Line – This line provides the recommended location for a sign. For ease of measurement in the field, the property line is considered to be the back of the public sidewalk. Unless otherwise noted, these distances are measured downstream from the property line, i.e., in the direction of the flow of traffic.

Number of Signs per Block Face – The maximum number of any individual sign that should be installed on one sign of the block. Please note, these numbers are based on standard City blocks of either 330 or 660 feet.

MUTCD FOOTNOTE: These guidelines are not intended to conflict in any way with either the USDOT Manual of Uniform Traffic Control Devices (MUTCD) or the IDOT Standard Highway Manual. In the event of any present or future conflict, the information provided in the MUTCD or IDOT Signs Manual takes precedence.



Type of poles – The type of pole on which a sign is installed. They include digs, drills, light poles, traffic poles, and mast arms. Dig and drill poles are provided specifically for sign installation. Dig poles are embedded into dirt or grass. Drill poles are fastened into sidewalk. When sign poles must be installed, dig installations are to be used whenever possible.

Mounting height – The range within which a sign must be mounted. This range varies between 7.0 feet and 10.5 feet. The 7.0 feet minimum clearance is a MUTCD standard and is the more critical of the two values. Exceptions to these guidelines are shown in the attached standard layout exhibits.

Mounting – Indicates the method used to mount a sign to a pole. They include center, flag, mast arm, and back-to-back. Each mounting method requires different hardware. In general, signs are center-mounted. Street Name Signs and No Outlet signs are flag-mounted. Mast arm mounts are limited to oversized street name signs and the regulatory traffic signs shown in the attached standard layout exhibits.

Angle – The mounting angle is the angle between a sign and the curb line. Regulatory parking signs with arrows should be mounted facing the street. Signs mounted at 90-degree angles are mounted perpendicular to the curb line.

Sign Blank- Indicates whether the sign message is printed on one or two sides of a sign. Single sided on one side, and double sided on both sides of a sign.

Co-Mounting – Identifies signs that can be installed on the same pole.

Exceptions – Lists the exceptions to the information provided in the standard application. For example, requirements that are specific to a sign or conditions (e.g. installing a mid-block stop sign at a mid-block crosswalk)

Notes – Provides additional information regarding the use of a sign.

Regulatory Authorities

MUTCD – Applicable sections are referenced, including the chapter or section number and title.

Illinois Statutes – Applicable sections are referenced, including the chapter or section number and title.

Municipal Code of Chicago – Applicable sections are referenced, including the chapter or section number and title.

Ordinance Required – Indicates whether an ordinance is required for specific signs to be installed.

MUTCD FOOTNOTE: These guidelines are not intended to conflict in any way with either the USDOT Manual of Uniform Traffic Control Devices (MUTCD) or the IDOT Standard Highway Manual. In the event of any present or future conflict, the information provided in the MUTCD or IDOT Signs Manual takes precedence.



EXHIBITS

MODEL: Default
 FILE NAME: S:\2020\2020\065 - CDOT - Jacobs - CDOT In-House and Support\CADD\CADD Sheets\01-Sign Post Mounting and Installation Details.dgn

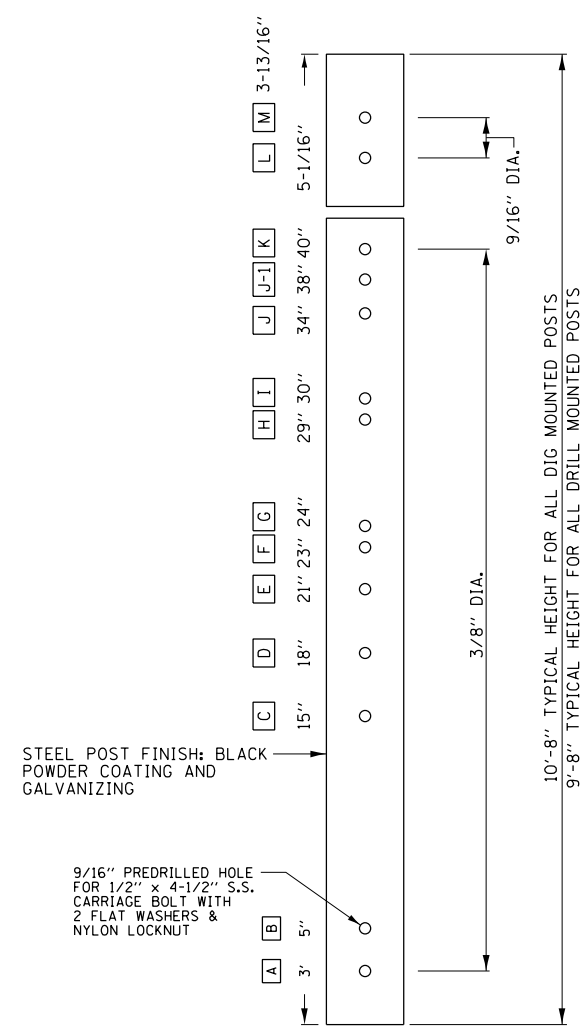

① ELEVATION: SIGN POST
 NOT TO SCALE

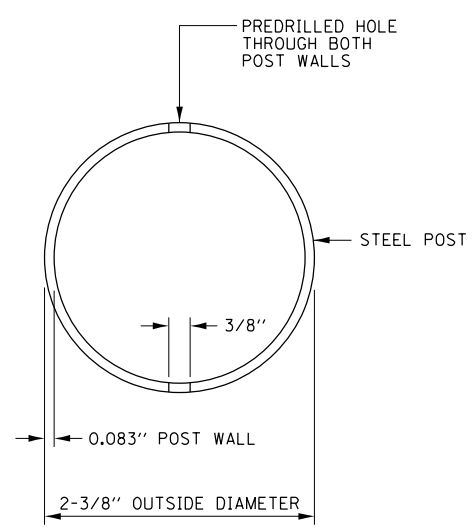

② SECTION: SIGN POST
 NOT TO SCALE

SIGN POST DETAILS
 NOT TO SCALE

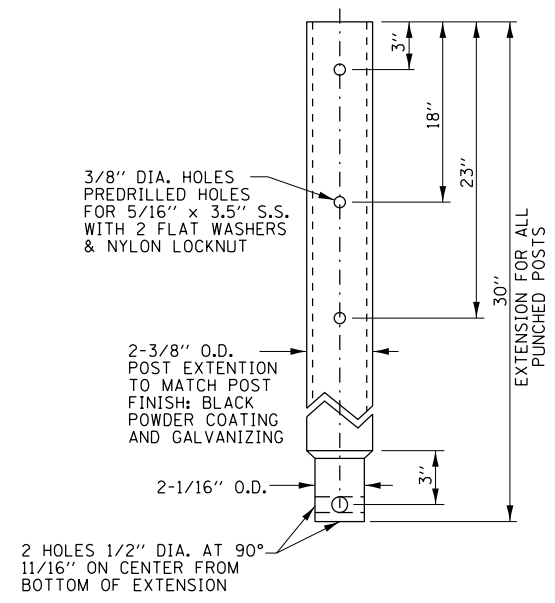

SECTION: DRILLED POST EXTENSION
 NOT TO SCALE

NOTES:

PROVIDE ADDITIONAL TWO SETS OF PREDRILLED HOLES ON EXTENSION. HOLES SHALL BE LOCATED AT 30° ANGLE TO HOLES SHOWN IN SECTION 3. HOLES SHALL ACCOMMODATE 5/16" x 3.5" S.S. SOCKET HEAD SCREW WITH 2 FLAT WASHERS AND NYLON LOCKNUT.

2 HOLE PATTERN 3" FROM REDUCED COLLAR

3 HOLE PATTERN FROM TOP OF POST 3", 18", 23" 23*8" x 0.08" WALL

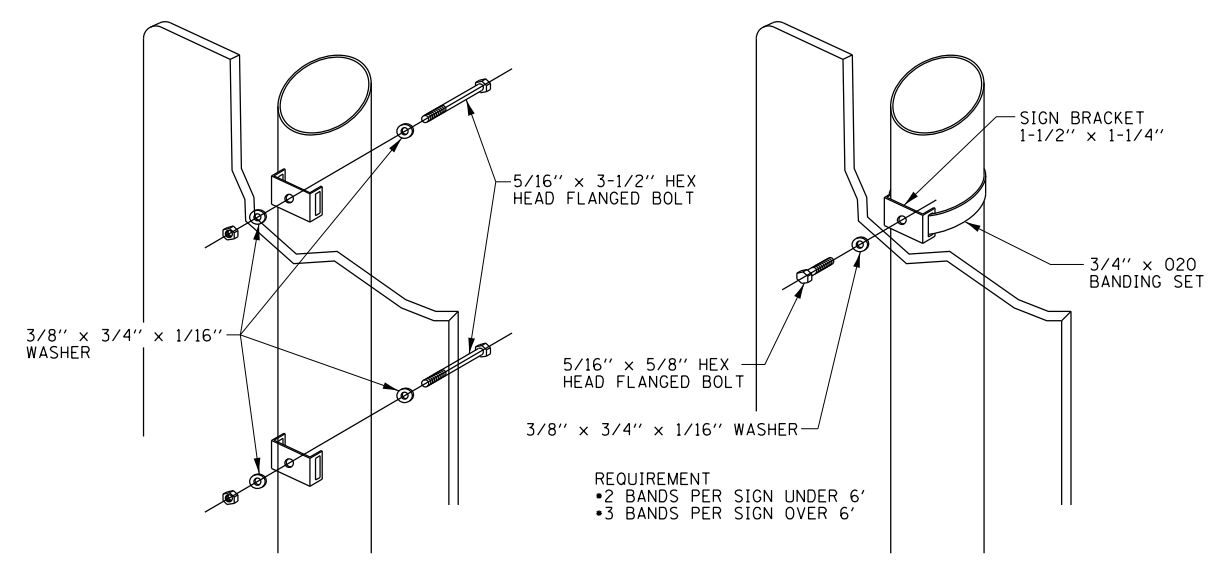

NOTE:
 PROVIDE MINIMUM 7'-0" CLEARANCE BETWEEN GROUND AND BOTTOM OF SIGN. RAISE INITIAL INSTALLATION HEIGHT IF REQ'D TO MAINTAIN 7' CLEAR.

CENTER MOUNTED SIGN ASSEMBLY
 NOT TO SCALE

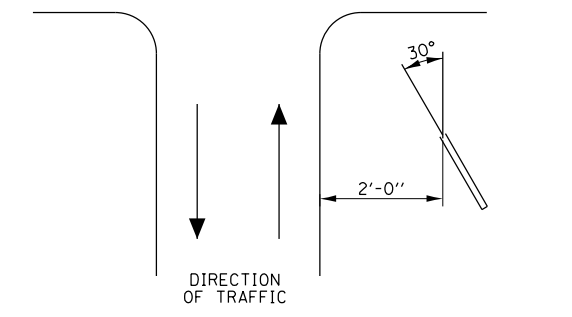

MOUNTING DETAIL
 FOR: TRAFFIC CONTROL SIGNS WITH DIRECTIONAL ARROWS
 PARKING REGULATIONS SIGNS WITH DIRECTIONAL ARROWS

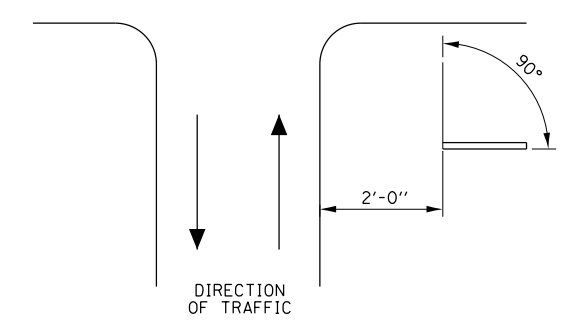

SIGN MOUNTING DETAILS
 NOT TO SCALE

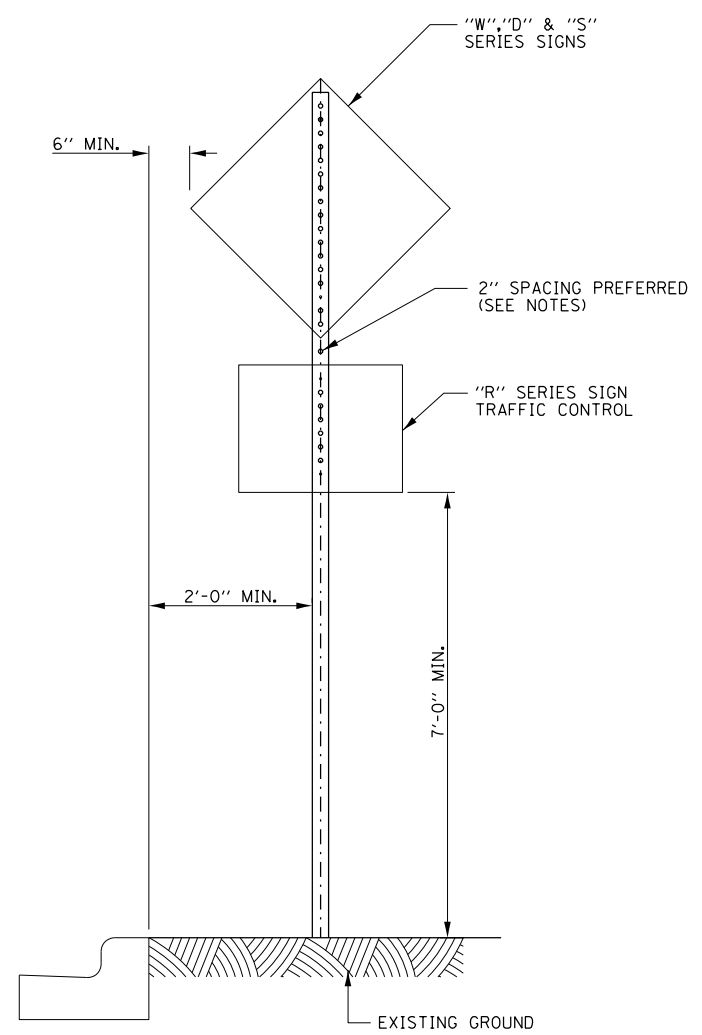

NOTE:
 2" SPACING MAY BE REDUCED IF REQUIRED TO MAINTAIN MIN. 7'-0" CLEARANCE TO BASE OF SIGN.

CENTER MOUNTED SIGN INSTALLATION
 NOT TO SCALE

DATE		REVISION		CITY OF CHICAGO	
				SIGN POST MOUNTING AND INSTALLATION DETAILS	
				DATE	DRAWN BY
				12/21/2020	

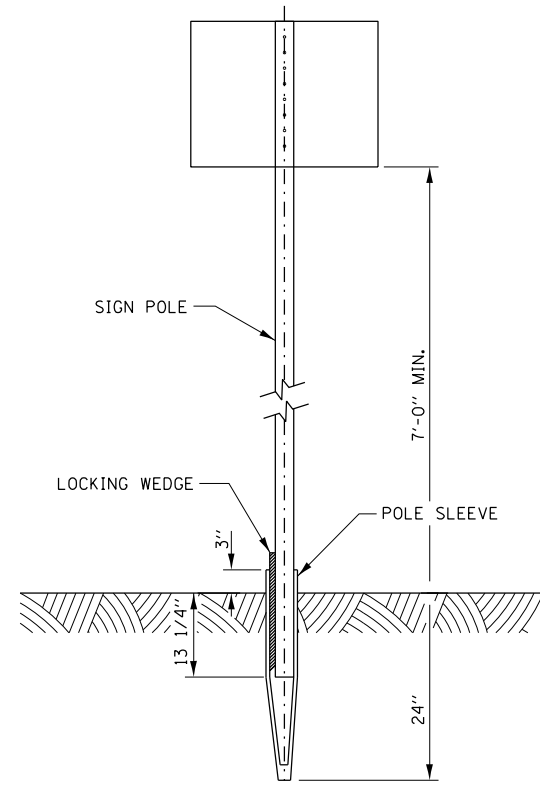

GROUND DIG INSTALLATION DETAIL
NOT TO SCALE

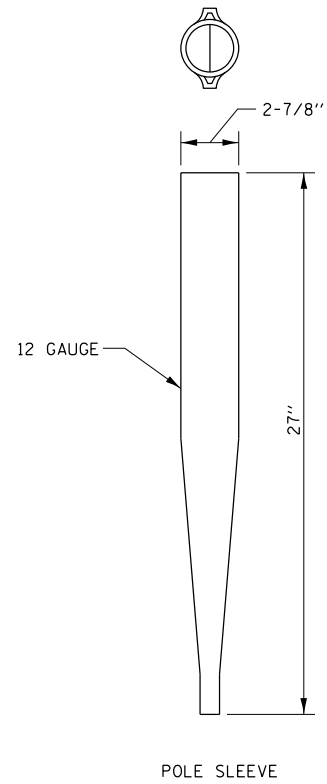

PIPE SOCKET AND WEDGE DETAIL
NOT TO SCALE

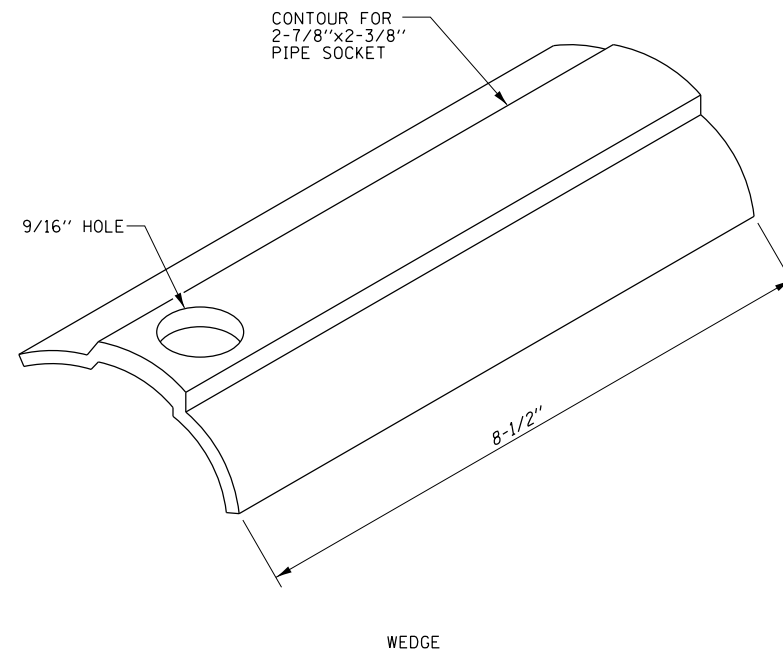

MODEL: Default
FILE NAME: S:\2020\20L065 - CDOT - Jacobs - CDOT In-House and Support\CADD\CADD Sheets\01-Sign Post Mounting and Installation Details.dgn

DATE		REVISION		CITY OF CHICAGO	
				DIG - SIGN POST MOUNTING AND INSTALLATION DETAILS	
		DATE		DRAWN BY	
		12/21/2020			

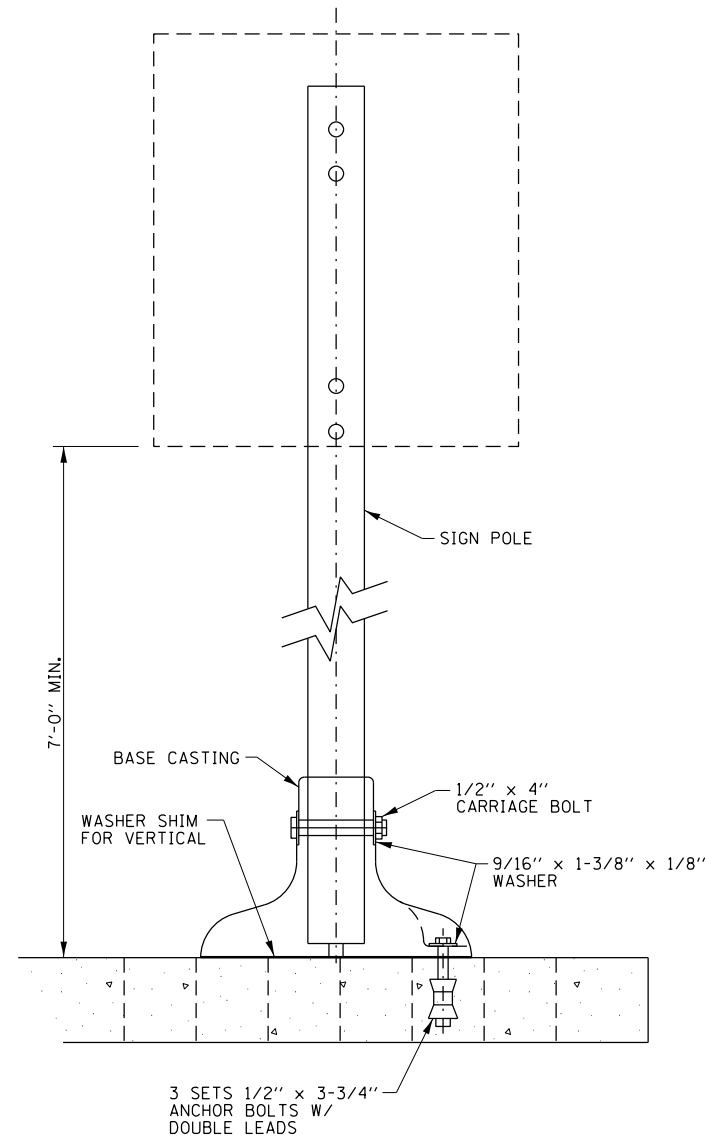

DRILL MOUNTED INSTALLATION DETAIL
NOT TO SCALE

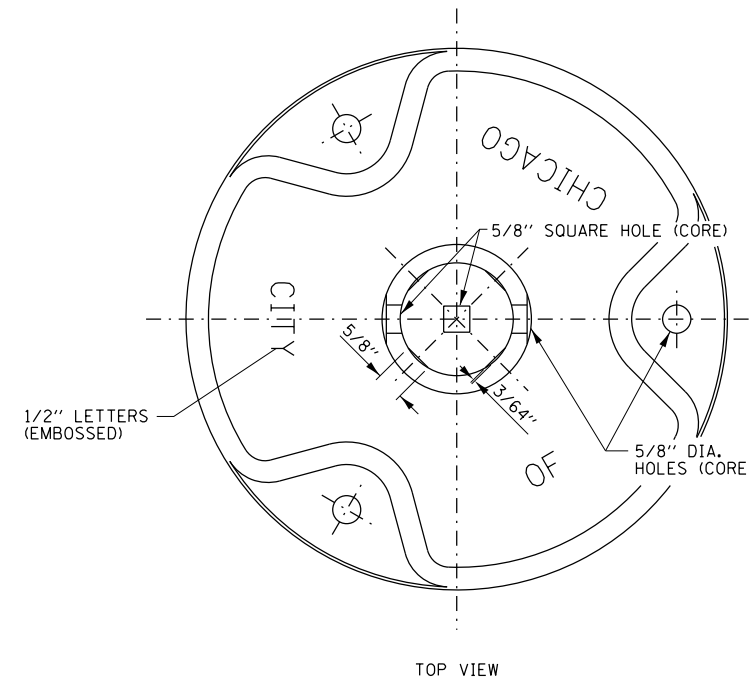

THE WELL SHALL BE CAPABLE OF RECEIVING A STANDARD 2" GALVANIZED PIPE FREELY

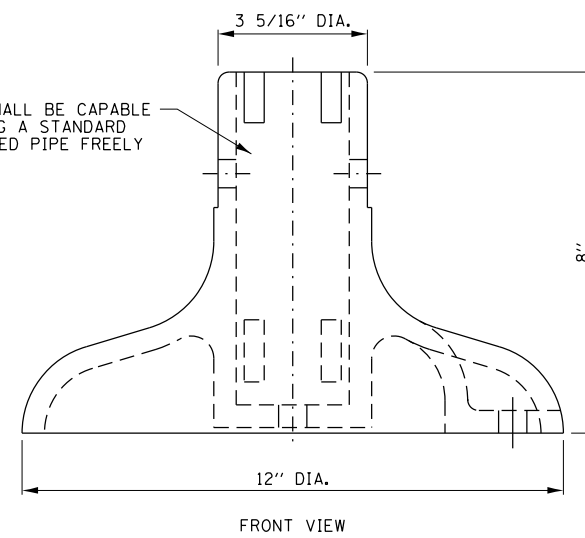

CITY OF CHICAGO SIGN BASE
NOT TO SCALE

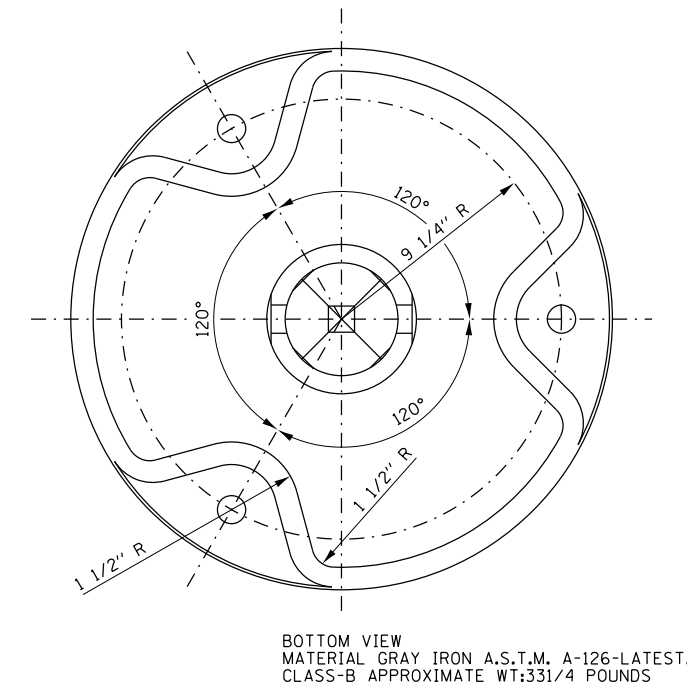

MATERIAL GRAY IRON A.S.T.M. A-126-LATEST, CLASS-B APPROXIMATE WT:33 1/4 POUNDS

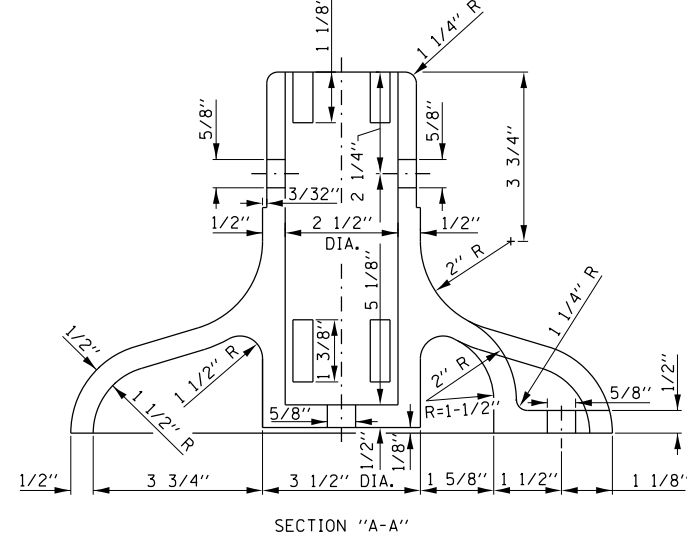

DATE		REVISION		CITY OF CHICAGO	
				DRILL - SIGN POST MOUNTING AND INSTALLATION DETAILS	
		DATE		DRAWN BY	
		12/21/2020			

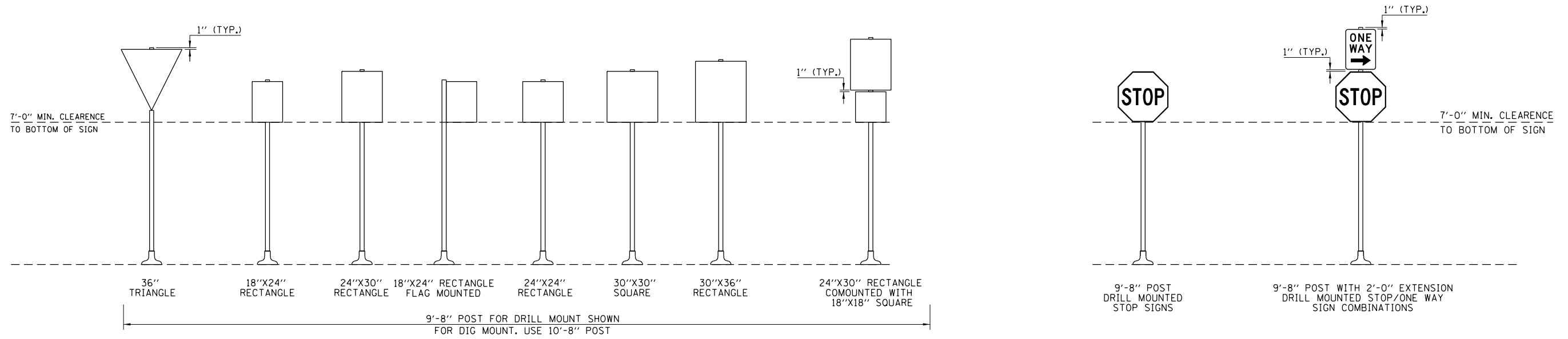

REGULATORY TRAFFIC SIGNS
NOT TO SCALE

STOP AND ONE-WAY SIGNS
NOT TO SCALE

NOTES:
THIS EXHIBIT ONLY SHOWS DRILL MOUNT FOR VISUAL PURPOSES. DIG MOUNT INSTALLATIONS SHOULD BE 10'-8".

IF THE MINIMUM CLEARANCE OF 7'-0" CANNOT BE ACHIEVED, INSTALL WITH A POST EXTENSION.

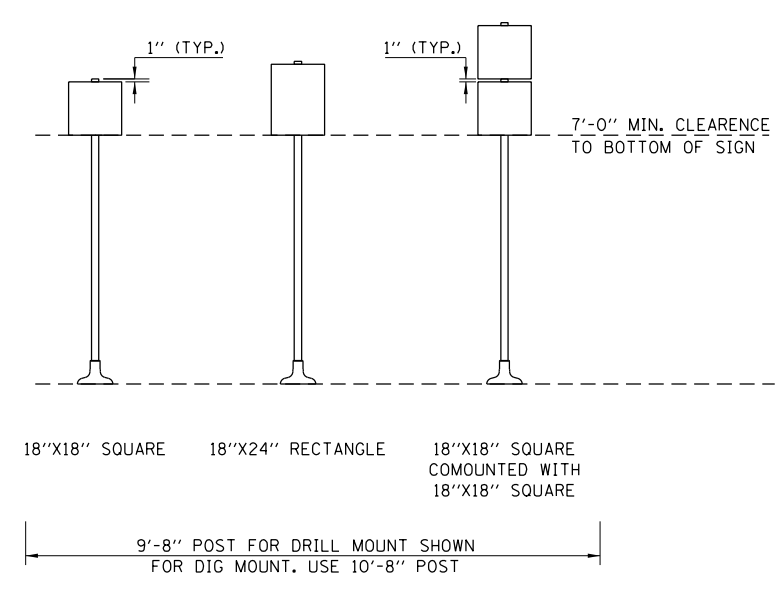

REGULATORY PARKING SIGNS
NOT TO SCALE

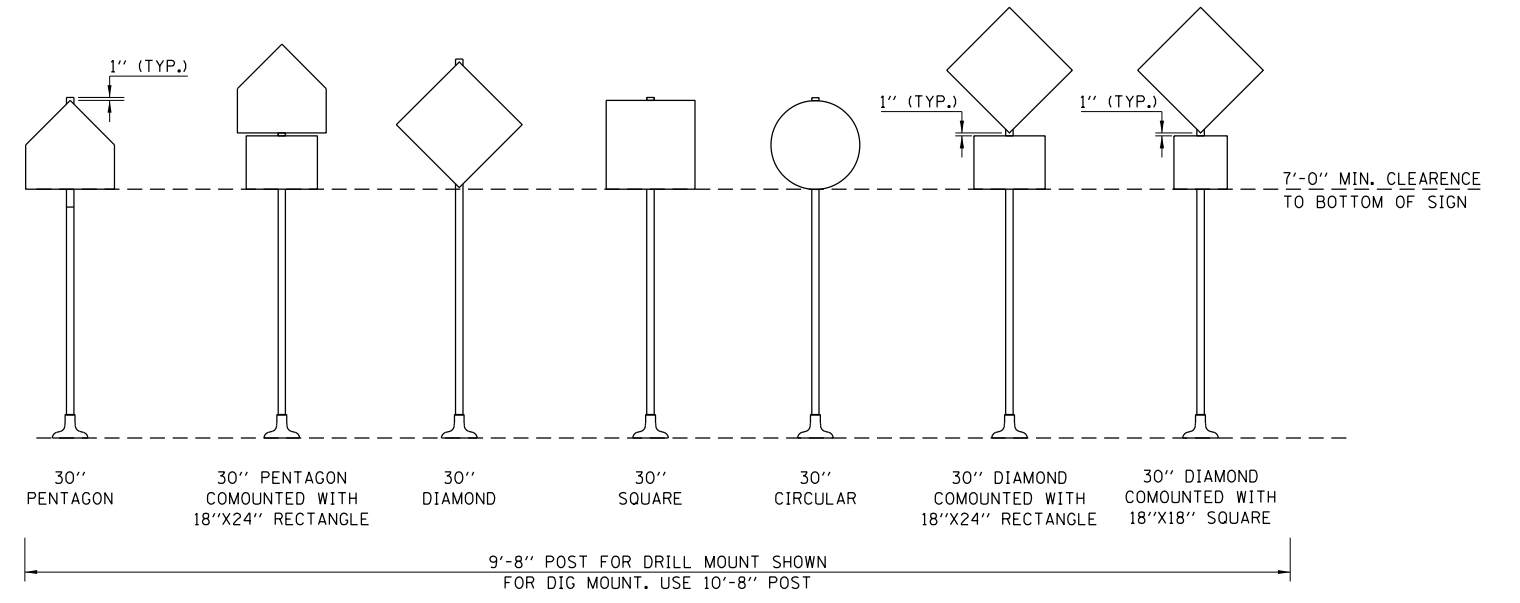

WARNING AND SCHOOL SIGNS
NOT TO SCALE

DATE		REVISION		CITY OF CHICAGO	
				SIGN LAYOUT INSTALLATION	
				DATE	DRAWN BY
				12/21/2020	

**GUIDE SIGNS
STREET NAME LOCATION AT UNSIGNALIZED
INTERSECTION OF TWO LOCAL STREETS**

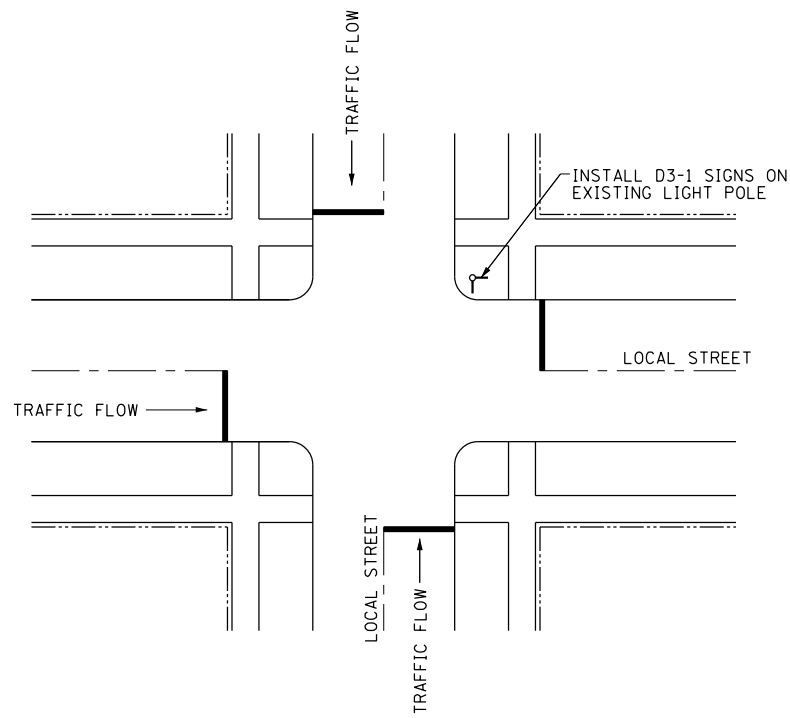

NOTES:

1. WHEN NO EXISTING LIGHT POLES ARE LOCATED AT INTERSECTION, INSTALL SIGNS ON NORTHEAST CORNER OR ABOVE STOP SIGNS.
2. WHEN MORE THAN ONE LIGHT POLE IS LOCATED AT INTERSECTION, INSTALL SIGNS ON ONE POLE USING ORDER OF PREFERENCE SHOWN BELOW.
 - (1) NORTHEAST CORNER
 - (2) NORTHWEST CORNER
 - (3) SOUTHEAST CORNER
 - (4) SOUTHWEST CORNER

TYPICAL LAYOUT
NOT TO SCALE

**GUIDE SIGNS
STREET NAME LOCATION AT UNSIGNALIZED
INTERSECTION OF LOCAL STREET
AND ARTERIAL STREET**

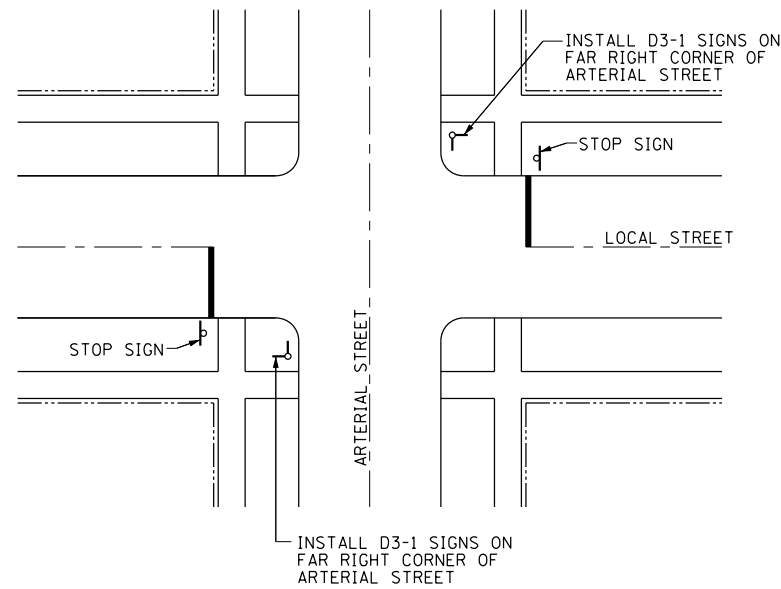

NOTES:

1. SIGNS SHOULD BE BANDED TO EXISTING LIGHT POLES WHENEVER POSSIBLE.
2. SIGNS MAY BE MOVED TO NEAR RIGHT CORNER TO AVOID INSTALLATION OF ADDITIONAL SIGN POLE.

TYPICAL LAYOUT
NOT TO SCALE

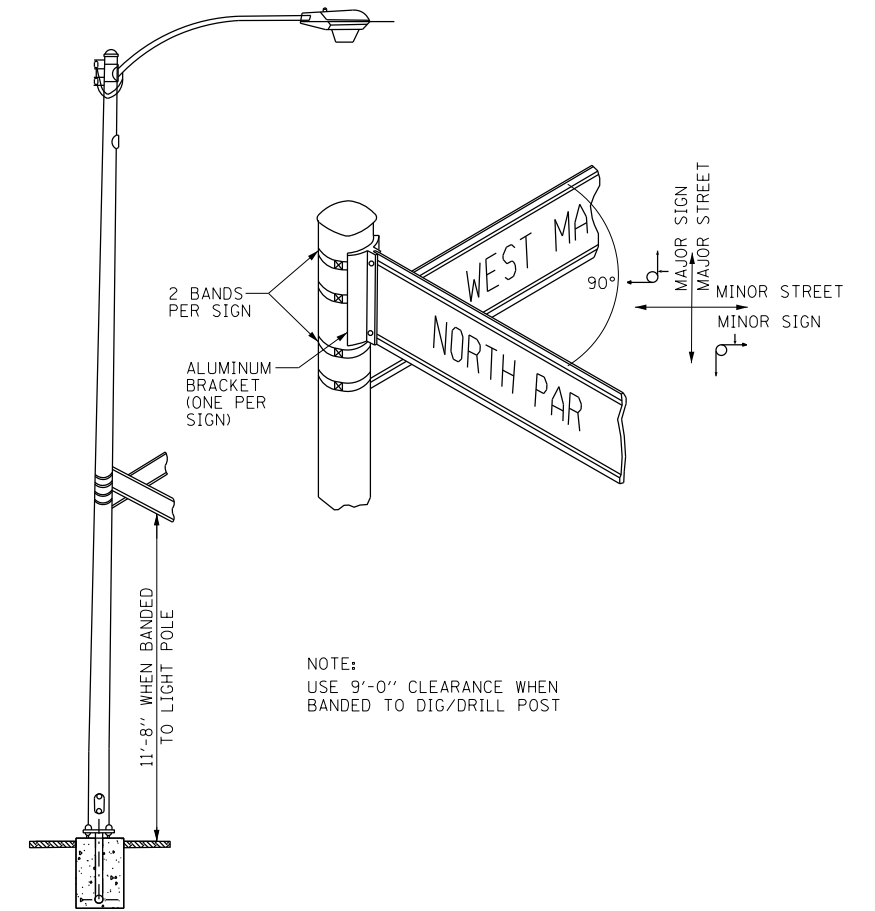

NOTE:
USE 9'-0" CLEARANCE WHEN BANDED TO DIG/DRILL POST

D3-1 SIGN ASSEMBLY
NOT TO SCALE

MODEL: Default
FILE NAME: S:\2020\2020\0605 - CDOT - Jacobs - CDOT In-House and Support\CADD\CADD Sheets\03-D3-1 Street Name Sign Installation.dgn

DATE		REVISION		CITY OF CHICAGO	
				D3-1 STREET NAME SIGN INSTALLATION	
				DATE	DRAWN BY
				12/21/2020	

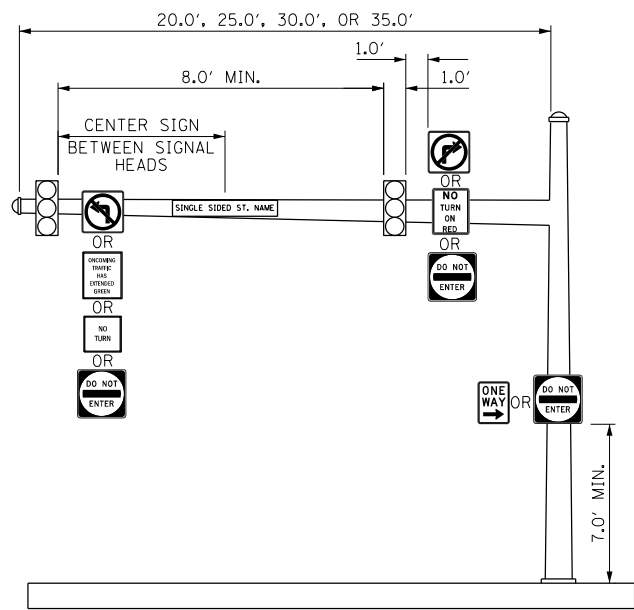

MAST ARM WITH TWO SIGNALS
NOT TO SCALE

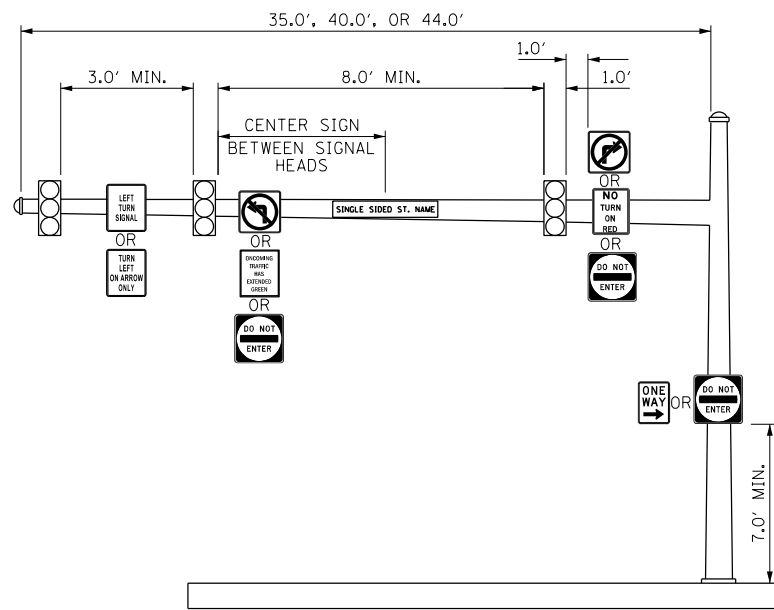

MAST ARM WITH THREE SIGNALS
NOT TO SCALE

NOTES:

- SIGNS INSTALLED ON SIGNAL POLES
- (2) OR (3) 18" OR 24" EXTRUDED ALUMINUM CHANNELS
- 5/16" BOLTS
- (2) TO (3) "C" CLAMP BRACKETS
- (2) HEAVY GAUGE BANDING STRAPS WITH BUTTERFLY CLIPS

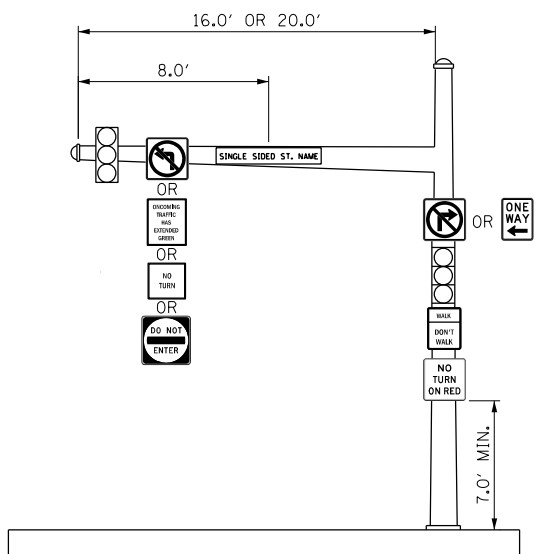

MAST ARM WITH ONE SIGNAL
NOT TO SCALE

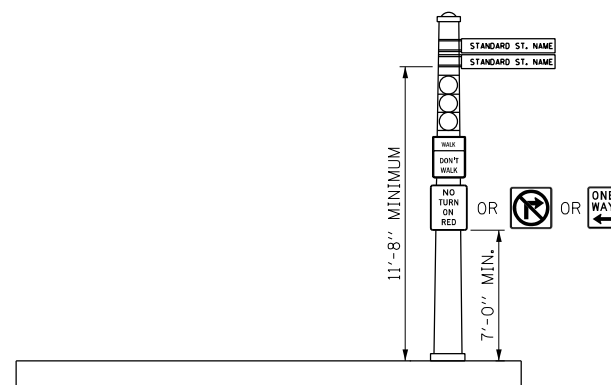

TYPICAL LAYOUT
NOT TO SCALE

DATE		REVISION		CITY OF CHICAGO	
				REGULATORY SIGN INSTALLATION ON TRAFFIC SIGNALS	
				DATE	DRAWN BY
				12/21/2020	

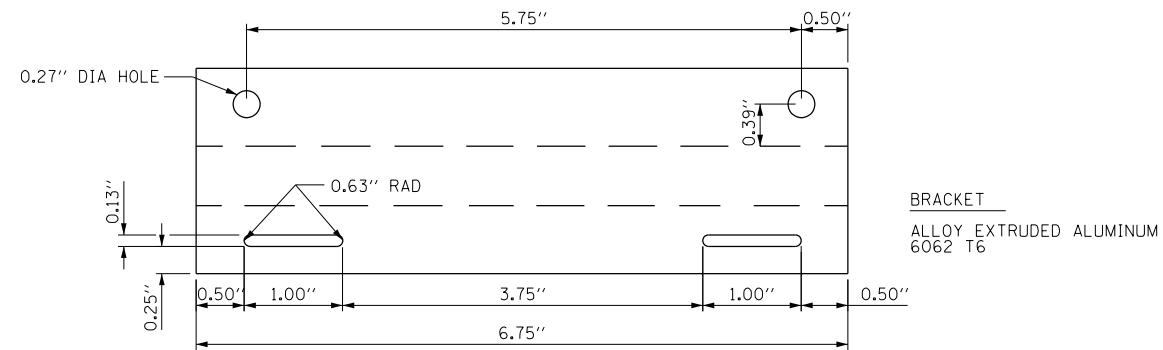

SIDE VIEW
NOT TO SCALE

BRACKET
ALLOY EXTRUDED ALUMINUM
6062 T6

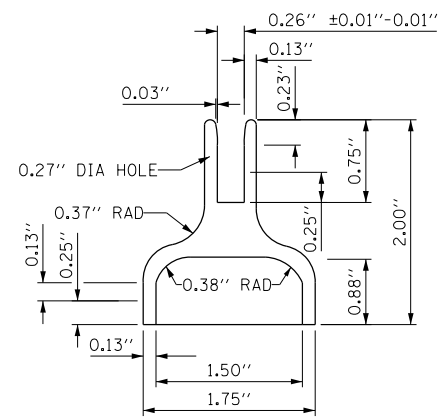

FRONT VIEW
NOT TO SCALE

SN-2 STREET NAME SIGN BRACKET
NOT TO SCALE

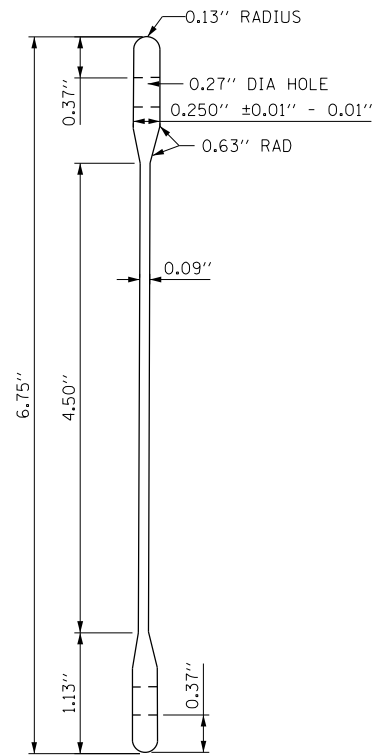

FRONT VIEW
NOT TO SCALE

SN-1 STREET NAME SIGN PANEL
NOT TO SCALE

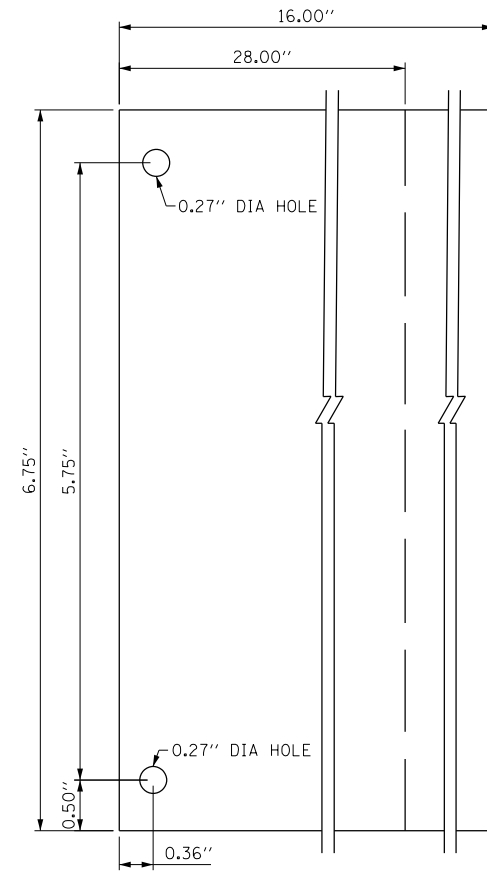

SIDE VIEW
NOT TO SCALE

SIGN BLANK
ALLOY EXTRUDED ALUMINUM
6062 T6

DATE		REVISION		CITY OF CHICAGO	
				D3-1 SIGN AND BRACKET SPECS	
		DATE		DRAWN BY	
		12/21/2020			

CDOT Sign Shop
Street Name Sign Standard
(July 16, 2019)

D3-1 Sign (post mounted):

- Use 6-3/4" sign blade.
- The lengths are 2 sizes only, 28" and 36". The amount of characters in the street name determines the selected size.
- 4-1/4" FHWA series D, upper and lower case is used with the lower-case letters approximately 3" proportionately.
- 2-1/2" FHWA series D, upper and lower case is used when specifying abbreviated (N) North, (E) East, (W) West or (S) South and abbreviated (St) Street, (Av) Avenue, (Pl) Place, etc.

D3-2 Sign (mast-arm mounted):

- Use 18" sign blades.
- A 24" mast-arm sign blade is only used when 2 street names must be included on the same sign.
- The lengths are 3 sizes only, 48", 60" and 72". The amount of characters in the street name determines the selected size.
- 6" FHWA series D, upper and lower case is used with the lower case approximately 4-1/4" proportionately.
- 4" FHWA series D upper and lower case is used when specifying the aforementioned abbreviated direction/designation.
- Use one-sided mast-arm mounted street name sign. Note: sign shop does not fabricate double-sided mast-arm signs any longer.
- FHWA series D is the same as Highway Gothic series D.

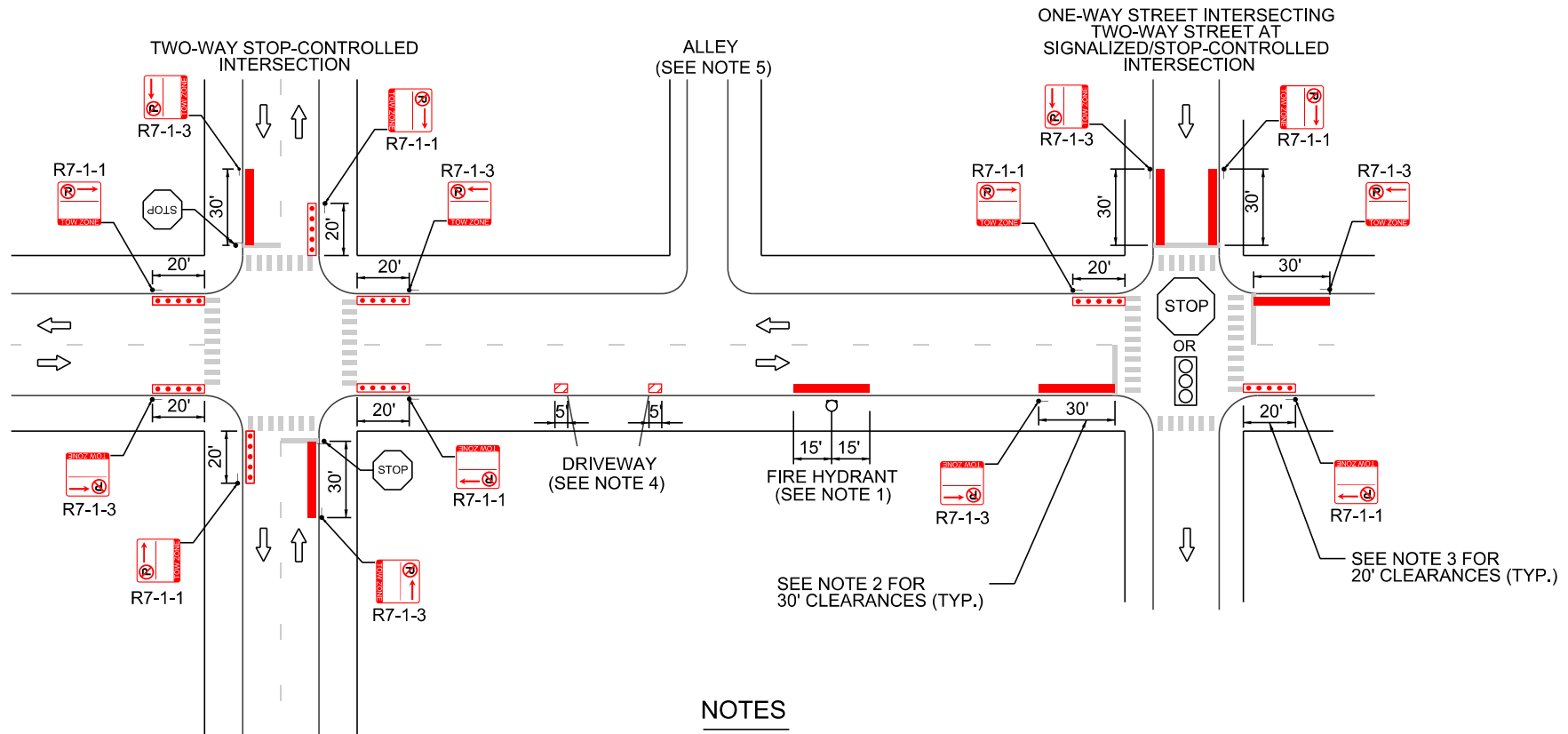

PARKING RESTRICTIONS LEGEND

- NO PARKING AT ALL TIMES REGARDLESS OF SIGNS
- NO PARKING WHERE OFFICIAL SIGNS ARE POSTED

NOTES

1. CITY MUNICIPAL CODE TITLE 9-64-100 (a): Parking prohibited "within 15 feet of a fire hydrant."
2. CITY MUNICIPAL CODE TITLE 9-64-100 (g): Parking prohibited "within 30 feet of an official traffic signal or stop sign on the approaching side."
3. CITY MUNICIPAL CODE TITLE 9-64-100 (f): Parking prohibited "within 20 feet of a crosswalk where official signs are posted."
4. PARKING CLEARANCE SIGNS ARE NOT REQUIRED AT DRIVEWAYS. IF DESIRED, THE PROPERTY OWNER CAN PAY TO HAVE THESE SIGNS INSTALLED THROUGH CDOT'S PRIVATE BENEFIT SIGN PROGRAM.
5. NO PARKING SIGNS MAY BE INSTALLED AT ALLEYS PER CDOT TRAFFIC STUDY.

DATE: 10/1/2018
 SCALE: NOT TO SCALE
 SHEET: 1 OF 2

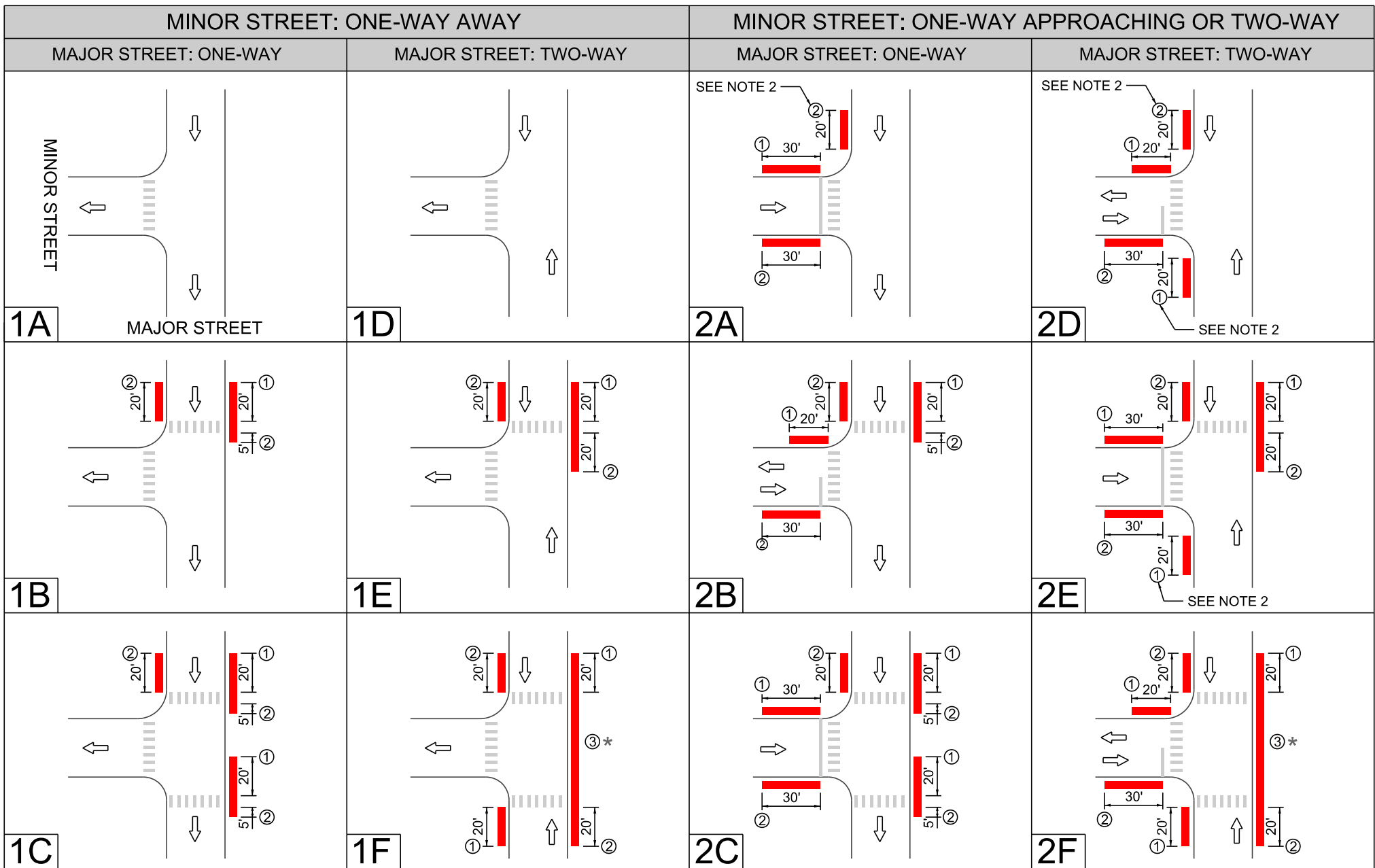

LEGEND

- ① R7-1-1
- ② R7-1-3
- ③ R7-1-4

* SIGN OPTIONAL

NOTES

1. CONSIDER RESTRICTING PARKING 20' FROM MARKED CROSSWALKS WHEN THERE IS AN APPROACHING MOVEMENT.
2. CONSIDERING RESTRICTING PARKING 20' FROM THE PROPERTY LINE ON THE RESPECTIVE LEGS OF THE MAJOR STREET TO INCREASE CORNER CLEARANCE VISIBILITY IF MINOR STREET TRAFFIC APPROACHING THE MAJOR STREET ENCOUNTERS ONCOMING TRAFFIC FROM EITHER DIRECTION, EVEN WHEN CROSSWALKS ARE NOT PRESENT.

DATE: 8/3/2018
 SCALE: NOT TO SCALE
 SHEET: 2 OF 2

CITY OF CHICAGO
 DEPARTMENT OF TRANSPORTATION
 DIVISION OF PROJECT DEVELOPMENT



CDOT DESIGN DETAIL
 ON-STREET PARKING CLEARANCES
 T-INTERSECTION

30" OCTAGON HIP WHITE CENTER MOUNT OVERSIZED STOP SIGN WITH 1160 PREMIUM GRAFFITI OVERLAY FILM

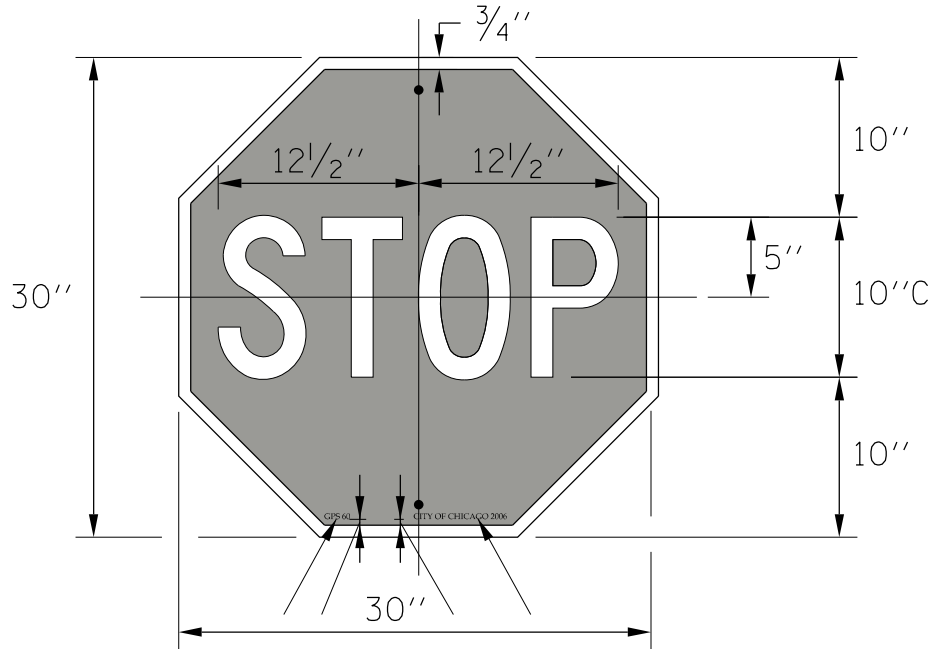

GPS 60 is 1/4" lettering
IN WHITE
helvetica heavy
bold font
Lettering is 3/8" from the
bottom of the red

CITY OF CHICAGO 2006
is 1/4" lettering size
IN WHITE
helvetica heavy
bold font
Lettering is 3/8" from the
bottom of the red

COLORS: LEGEND - WHITE (REFLECTIVE) *reduce spacing 40%
BACKGROUND - RED (REFLECTIVE)

Holes are 3/8" on center and 2" from the edge of the plate.

	DATE	REVISION	CITY OF CHICAGO		
			30" OCTAGON - STOP SIGN R1-1		
			DATE	DRAWING	DRAWN BY
			10/31/12	2	CDOT

36" OCTAGON HIP WHITE CENTER MOUNT OVERSIZED STOP SIGN WITH 1160 PREMIUM GRAFFITI OVERLAY FILM

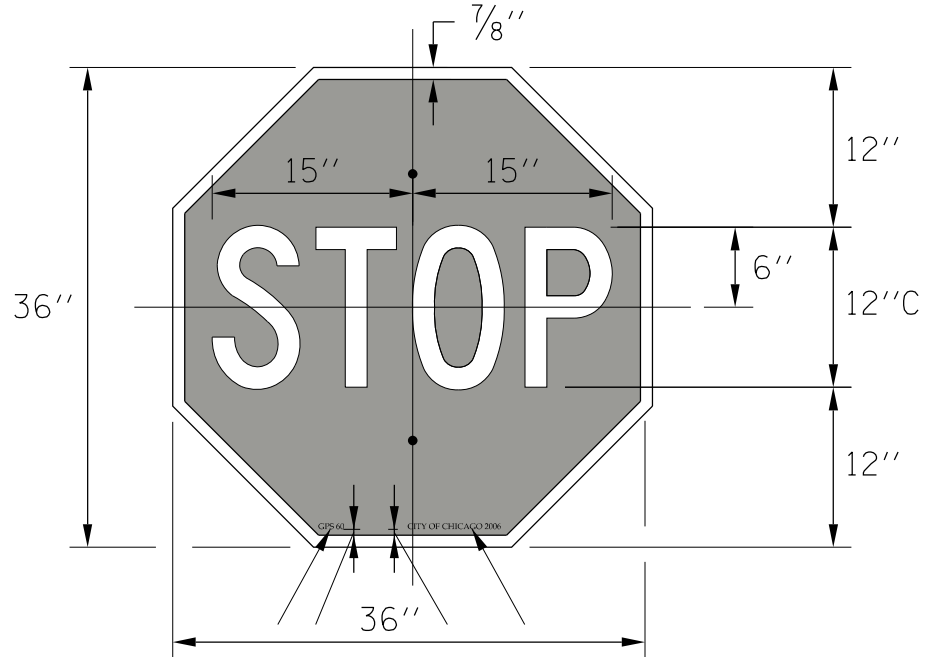

GPS 60 is 1/4" lettering
IN WHITE
helvetica heavy
bold font

Lettering is 3/8" from the
bottom of the red

CITY OF CHICAGO 2006
is 1/4" lettering size
IN WHITE
helvetica heavy
bold font

Lettering is 3/8" from the
bottom of the red

COLORS: LEGEND - WHITE (REFLECTIVE) *reduce spacing 40%
BACKGROUND - RED (REFLECTIVE)

Holes are 3/8" on center and 8" from the edge of the plate.

	DATE	REVISION	CITY OF CHICAGO		
			36" OCTAGON - STOP SIGN R1-1		
			DATE	DRAWING	DRAWN BY
			10/31/12	1	CDOT

30"X 30" DO NOT ENTER HIP WHITE CENTER MOUNT WITH 1160 PREMIUM GRAFFITI OVERLAY FILM

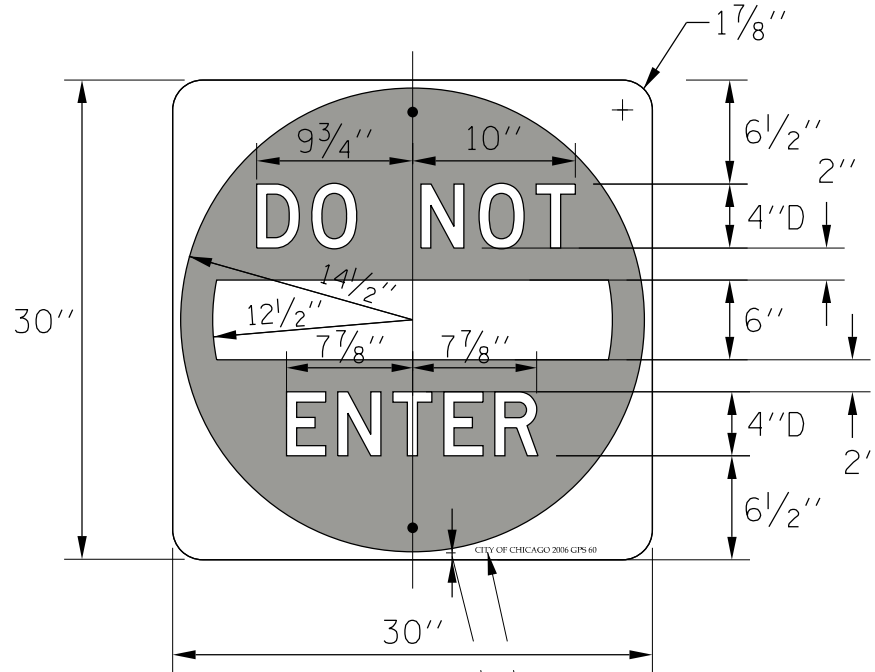

CITY OF CHICAGO 2006 GPS 60
is 1/4" letter size
IN RED
helvetica heavy
bold font

Lettering is 3/8" from
the bottom of
the plate

COLORS: SYMBOL - RED (REFLECTIVE)
LEGEND & BACKGROUND - WHITE (REFLECTIVE)

Holes are 3/8" on center and 2" from the edge of the plate.



DATE	REVISION	CITY OF CHICAGO		
		30"X30" - DO NOT ENTER R5-1		
		DATE	DRAWING	DRAWN BY
		10/31/12	3	CDOT

18"X24" SINGLE FACED CENTER MOUNT HIP WHITE WITH 1160 PREMIUM GRAFFITI OVERLAY ONE WAY ARROW

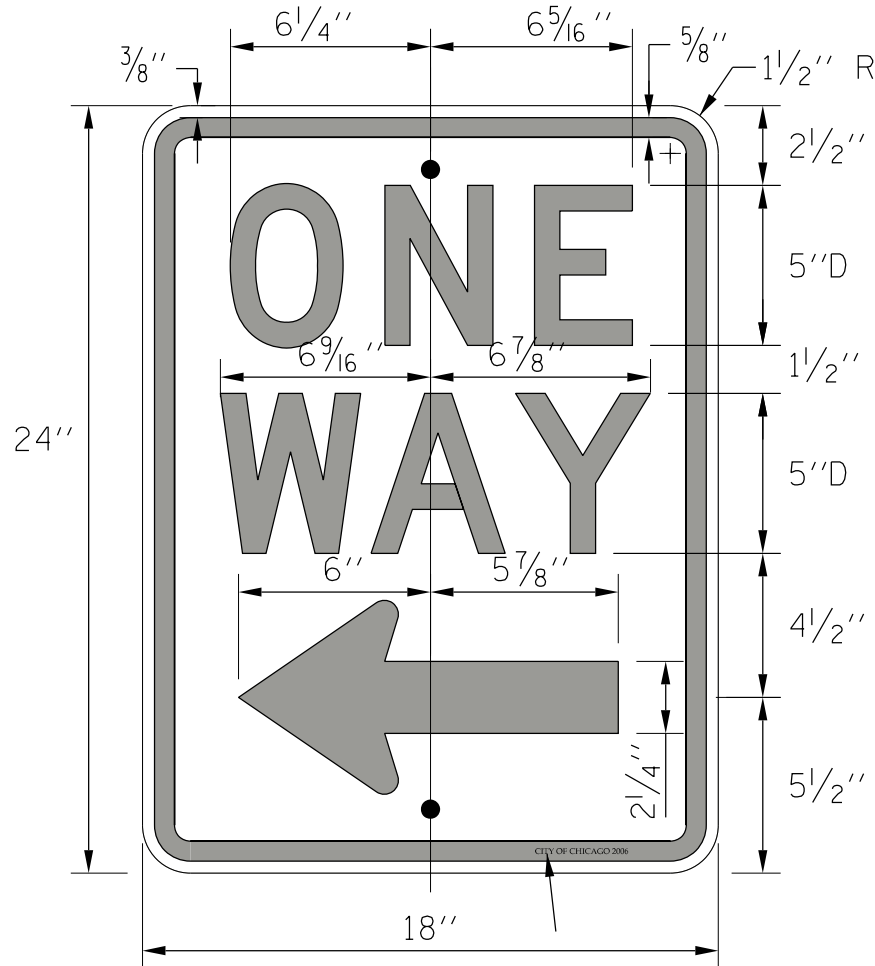

CITY OF CHICAGO 2006 GPS 60
is 1/4" lettering size
IN WHITE
helvetica heavy
bold font

COLORS: LEGEND - BLACK
BACKGROUND - WHITE (REFLECTIVE) *See page 6-2 for arrow design

Holes are 3/8" on center and 2" from the edge of the plate

	DATE	REVISION	CITY OF CHICAGO		
			18"X24" - ONE WAY (LEFT) R6-2L		
			DATE	DRAWING	DRAWN BY
			10/31/12	4	CDOT

18"X24" SINGLE FACED CENTER MOUNT HIP WHITE
WITH 1160 PREMIUM GRAFFITI OVERLAY
ONE WAY ARROW

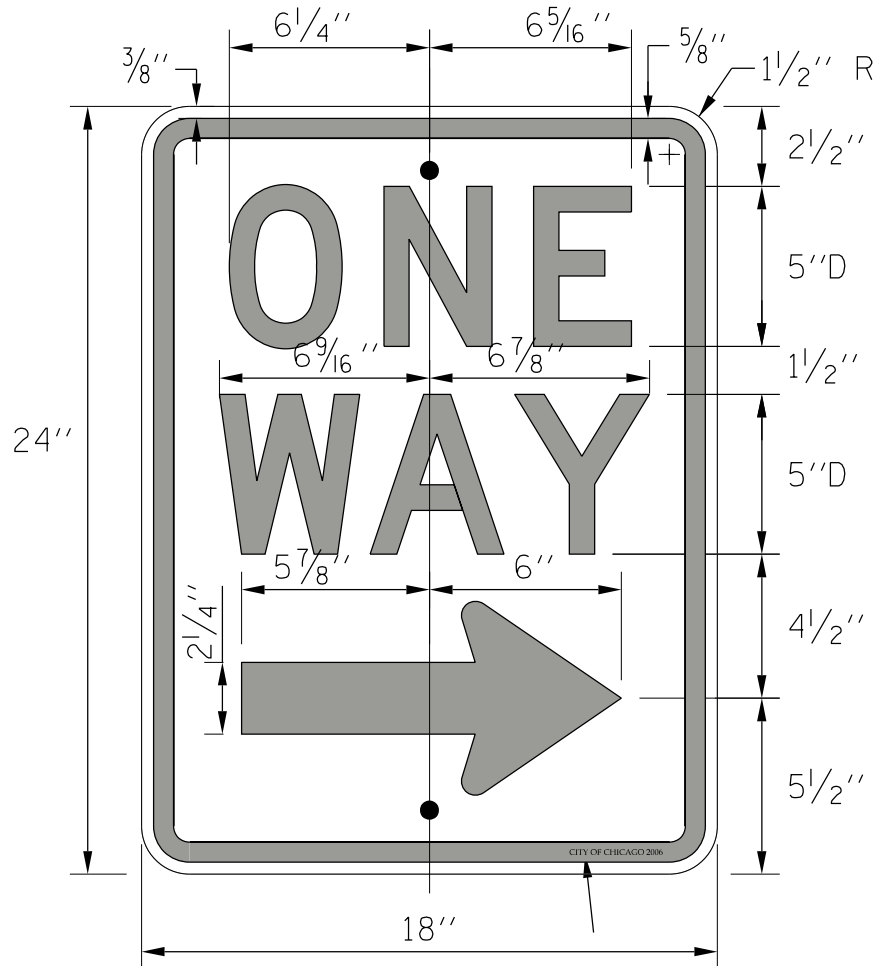

CITY OF CHICAGO 2006 GPS 60
is 1/4" lettering size
IN WHITE
helvetica heavy
bold font

COLORS: LEGEND - BLACK
BACKGROUND - WHITE (REFLECTIVE)

*See page 6-2 for arrow design

Holes are 3/8" on center and 2" from the edge of the plate



DATE	REVISION	CITY OF CHICAGO		
		18"X24" - ONE WAY (RIGHT) R6-2R		
		DATE	DRAWING	DRAWN BY
		10/31/12	5	CDOT

DATE

REVISION

CITY OF CHICAGO

DATE
10/31/12

DRAWING
27

DRAWN BY
CDOT

30" PENTAGON - SCHOOL ADVANCE
S1-1

30" PENTAGON SCHOOL ADVANCE
CENTER MOUNT WITH
1160 GPS GRAFFITI OVERLAY FILM

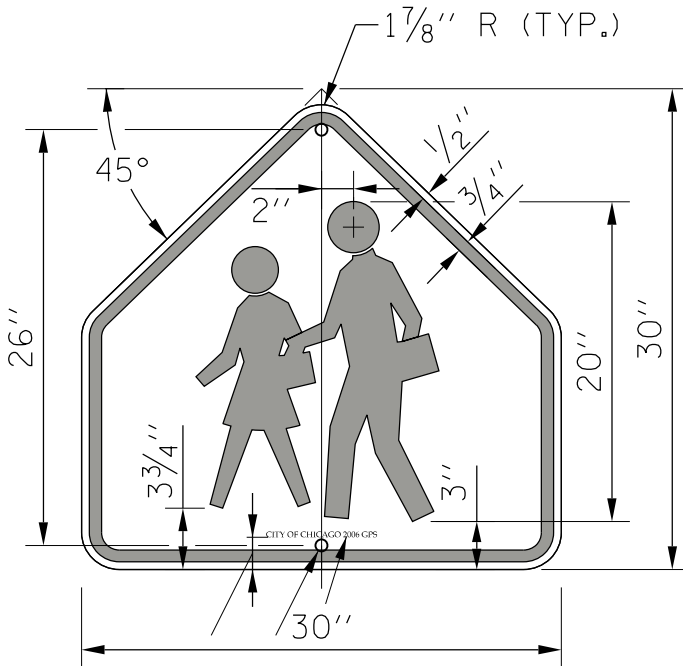

CITY OF CHICAGO 2006 GPS 60
is 1/4" letter size IN BLACK
helvetica heavy bold font

1 1/2" from the bottom of the plate

Lettering is 2" from the bottom of
the plate

COLORS: SYMBOL - BLACK
BACKGROUND - YELLOW (REFLECTIVE)

Bottom hole is 3/8" on center and 1 1/2" from the edge of the plate.

30" PENTAGON FOR SCHOOL SIGN BLANK
WITH HOLE PATTERN FOR RAW
ALUMINUM AND PRE-MADE SIGNS

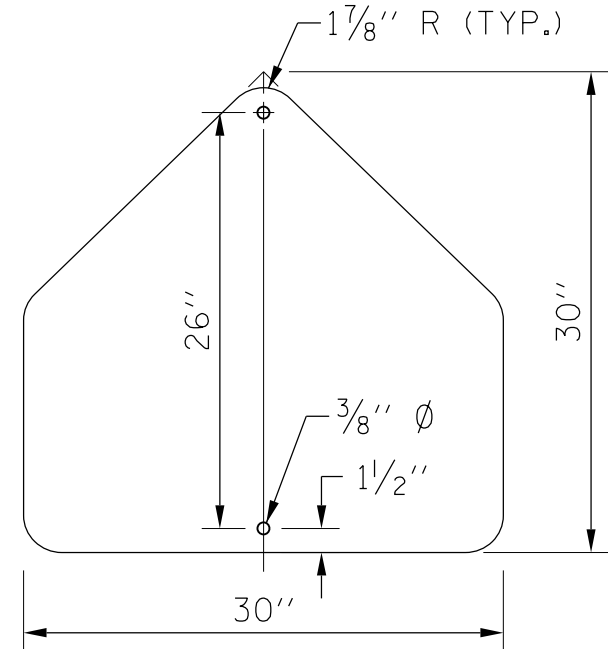

SPECIFICATION 44578, ALUMINUM SIGN
BLANKS, SIGNS, COROPLAST SHEETS

18"X18" WHITE SIGN BLANK FOR PRE-MADE NO PARKING TOW ZONE WITH ARROW

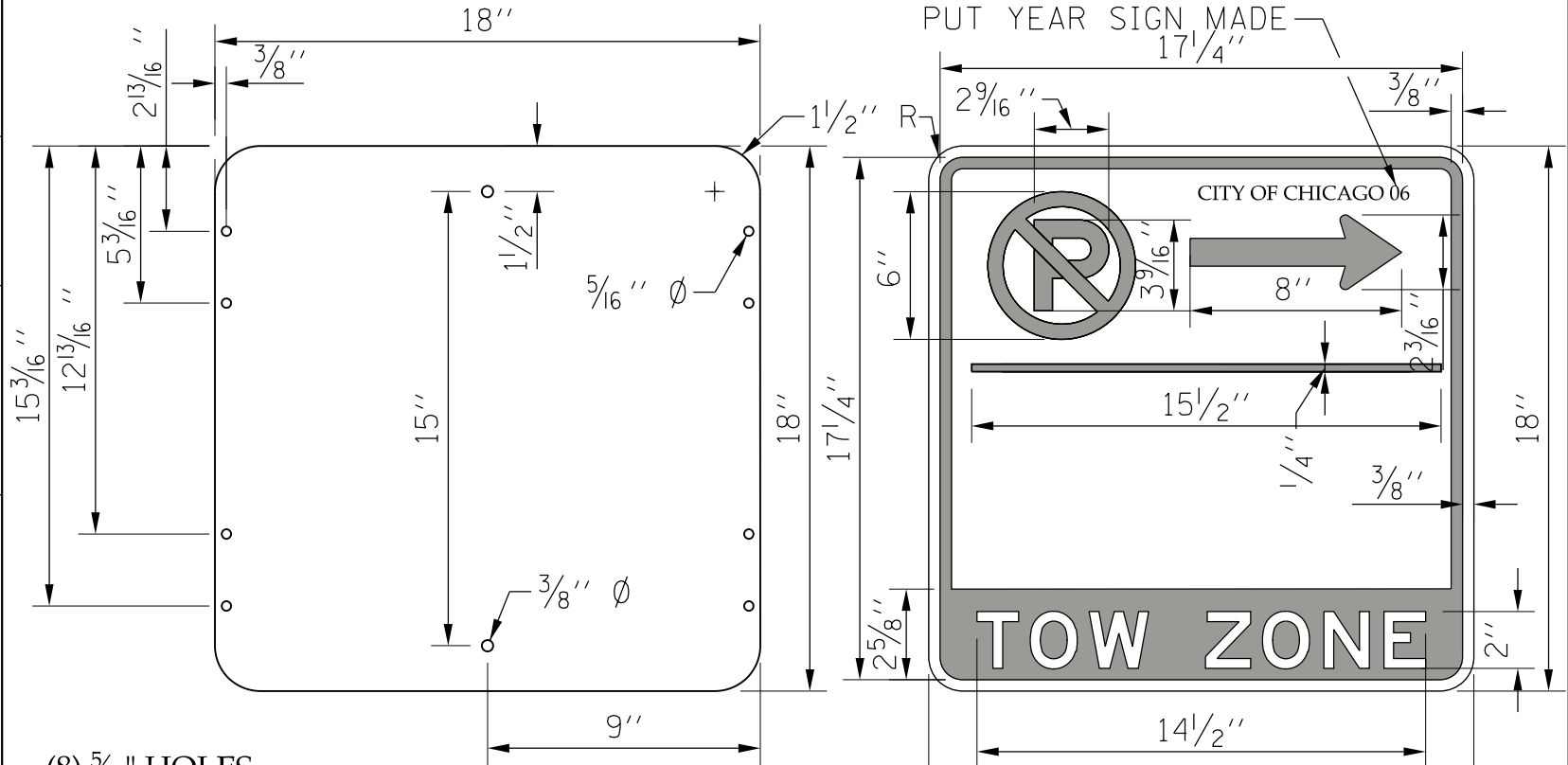

(8) 5/16" HOLES
(2) 3/8" HOLES
ALL HOLE MEASUREMENTS
ON CENTER.

SPECIFICATION 44578, ALUMINUM SIGN
BLANKS, SIGNS, COROPLAST SHEETS

COLORS: BLACK FOR P SYMBOL
RED FOR ALL OTHERS EXCEPT TOW ZONE WORDING
WHITE FOR TOW ZONE WORDING

NOTE: NTS

DATE		REVISION		CITY OF CHICAGO	
12/23/2020		Revision 1		18"X18" -	
				NO PARKING TOW ZONE WITH	
				ARROW	
DATE		DRAWING		DRAWN BY	
10/31/12		45		CDOT	

DATE
12/23/2020

REVISION
Revision 1

DATE
10/31/12

DRAWING
46

DRAWN BY
CDOT

CITY OF CHICAGO
18"X18" - DOUBLE FACED BUS STOP WITH ARROW

18"X18" RAW ALUMINUM SIGN BLANK FOR PRE-MADE BUS STOP WITH ARROW SIGN

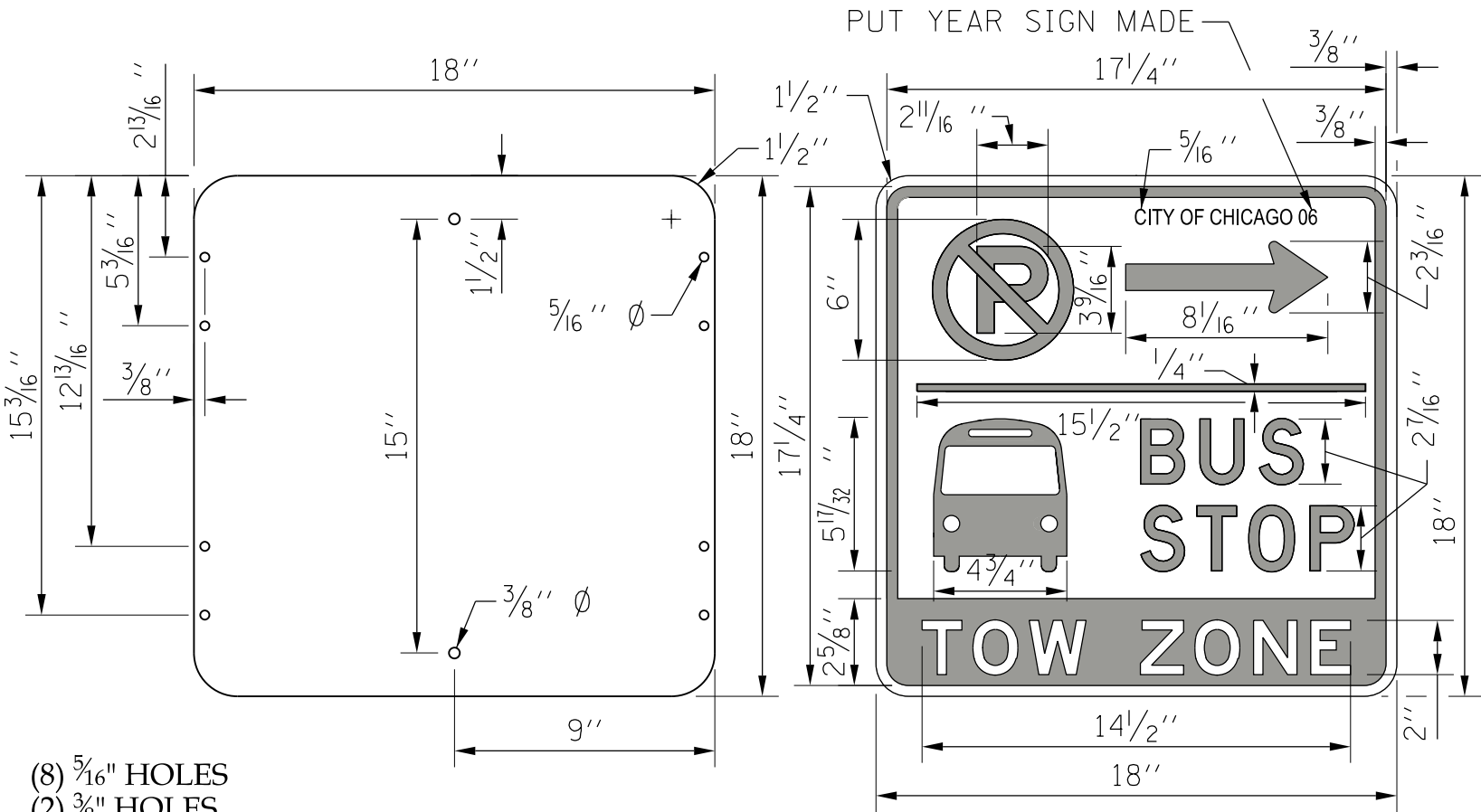

(8) 5/16" HOLES
(2) 3/8" HOLES
ALL HOLE MEASUREMENTS ON CENTER.

COLORS: BLACK - FOR BUS & P SYMBOL
RED - FOR ALL OTHERS EXCEPT TOW ZONE WORDING
WHITE - FOR TOW ZONE WORDING

SPECIFICATION 44578, ALUMINUM SIGN
BLANKS, SIGNS, COROPLAST SHEETS

DATE	REVISION	CITY OF CHICAGO
DATE	DRAWING	36" PENTAGON - SCHOOL S1-1
10/31/12	47	
DRAWN BY		
CDOT		

36" PENTAGON SCHOOL CENTER MOUNT WITH 1160 GPS GRAFFITI OVERLAY FILM

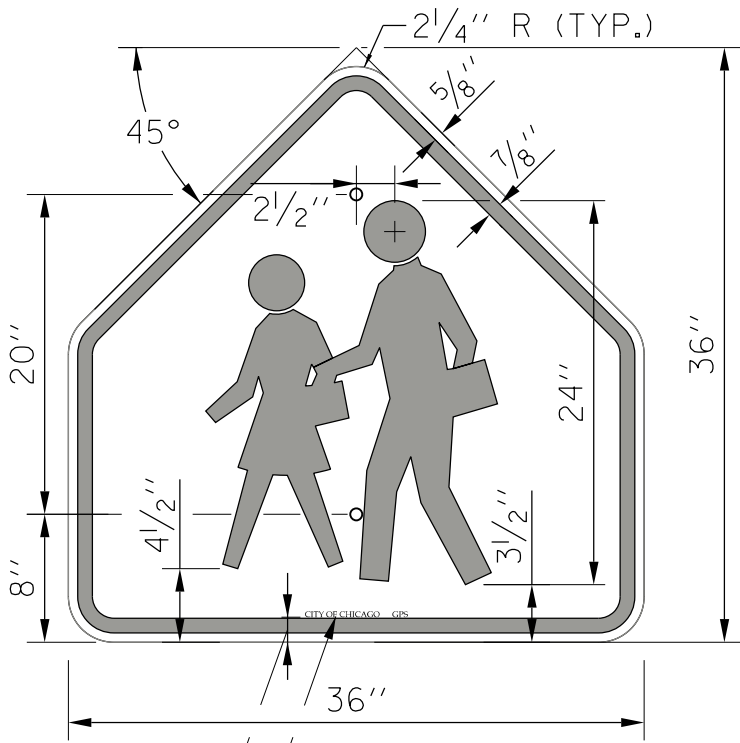

CITY OF CHICAGO GPS
is 3/8" letter size IN BLACK
in highway gothic D

Lettering is 1 3/4" from the bottom of the plate.
Note, the year is changed to reflect when made.

COLORS: SYMBOL - BLACK
BACKGROUND - YELLOW (REFLECTIVE)
- FLOURESCENT YELLOW GREEN

Holes are 3/8" on center and 8" from the edge of the plate.

36" PENTAGON FOR SCHOOL SIGN BLANK WITH HOLE PATTERN FOR RAW ALUMINUM AND PRE-MADE SIGNS

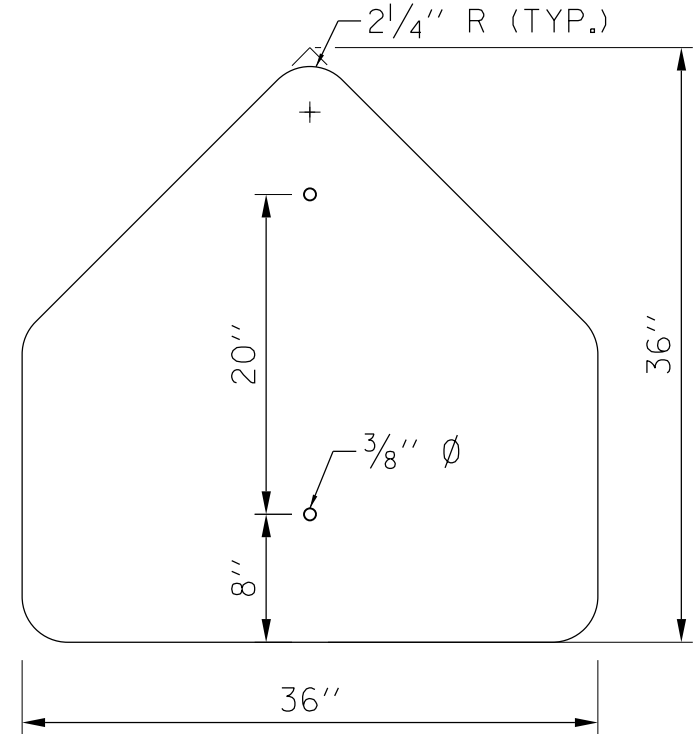

SPECIFICATION 44578, ALUMINUM SIGN BLANKS, SIGNS, COROPLAST SHEETS

24"X30" SINGLE FACED CENTER MOUNT ONE WAY WITH LEFT OR RIGHT ARROWS

24"X30" RAW ALUMINUM
(0.080) SIGN BLANK

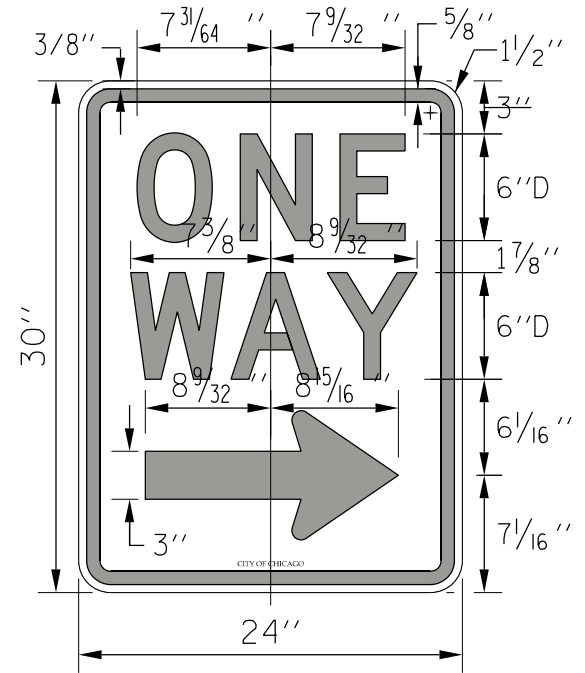
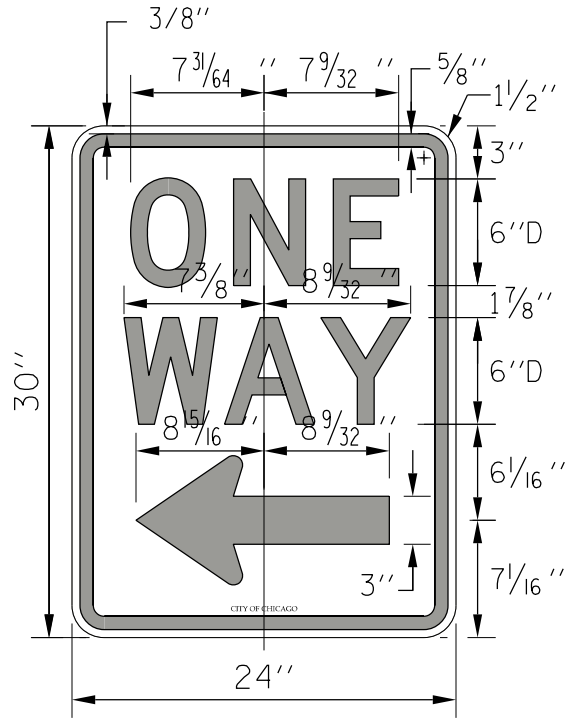
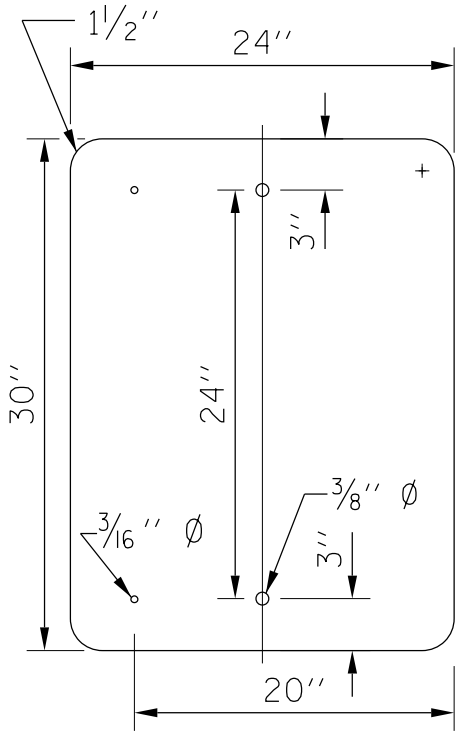

- (2) $\frac{3}{16}$ " HOLES
- (2) $\frac{3}{8}$ " HOLES
- ALL HOLE MEASUREMENTS ON CENTER.

MATERIAL: 0.080 ALUMINUM POWDER COATED WHITE BACKGROUND OR RAW ALUMINUM WITH 3M WHITE ENGINEER GRADE/UTILITY GRADE OR HIGH INTENSITY PRISMATIC GRADE REFLECTIVE SHEETING

COLORS: LEGEND - BLACK
BACKGROUND - WHITE

LETTERING STYLE: USE SERIES 2000 FROM THE MUTCD 2009 STANDARD HIGHWAY SIGNS BOOK

CITY OF CHICAGO

24"X30" - SINGLE FACED ONE WAY
WITH LEFT OR RIGHT ARROWS

DATE

REVISION

DATE

DRAWING

DRAWN BY

10/31/12

48

CDOT

SPECIFICATION 44578, ALUMINUM SIGN
BLANKS, SIGNS, COROPLAST SHEETS