



CHATHAM COMMERCIAL CORRIDOR DESIGN GUIDELINES



CITY OF CHICAGO



DEPARTMENT OF PLANNING AND DEVELOPMENT



DECEMBER 2018





The owners of Brown Sugar and 6th Ward Alderman Roderick Sawyer enjoy the parklet structure on 75th Street.

ACKNOWLEDGMENTS

CITY OF CHICAGO
MAYOR'S OFFICE
Bernita Johnson-Gabriel

6TH WARD
Alderman Roderick T. Sawyer

DEPARTMENT OF PLANNING
AND DEVELOPMENT
Eleanor Gorski, Bureau Chief
Cindy Roubik
Benet Haller
Isabel Lara
Luis Monterrubio
Susan Parks
Larry Shure
Nolan Zaroff

DEPARTMENT OF
TRANSPORTATION
Lubica Benak
Luann Hamilton
Vanessa Irizarry
Michael Simon

CONGRESS FOR
NEW URBANISM
Kristen Dunphey
Lynn Richards

COTTAGE GROVE
PLANTER SOCIETY
Leiana Gary

GREATER CHATHAM INITIATIVE
Nicole Bridges
Delmar Fears
Gaylord Minett, Jr.
Nedra Sims-Fears

THE RICHARD H. DRIEHAUS
FOUNDATION
Kim Coventry

FARR ASSOCIATES
Doug Farr
Aly Andrews
Cindy Gray Schneider
Tony Holub
Grant Hromas

"I was born here and continue to live here with my wife and children. I remember 75th Street as a busy thriving neighborhood, where businesses flourish, nightlife, social life, shopping up and down the streets, and we never had a problem. I want to see that to occur again"

—Alderman Roderick T. Sawyer, 6th Ward



CHATHAM COMMERCIAL CORRIDOR DESIGN GUIDELINES

DEPARTMENT OF PLANNING AND DEVELOPMENT

TABLE OF CONTENTS

EXECUTIVE SUMMARY.....	04
1. INTRODUCTION AND CONTEXT.....	05
2. EXISTING INCENTIVES.....	07
3. COMMERCIAL CORRIDOR DESIGN GUIDELINES.....	08
APPENDICES.....	17



EXECUTIVE SUMMARY

Chatham is one of several neighborhoods on the South Side of Chicago in which the City has established incentives to provide investment opportunities for the rehabilitation of existing or construction of new buildings. Some of these incentives include:

- Tax Increment Finance Districts (TIF)
- Special Service Area (SSA #51)
- Neighborhood Opportunity Fund
- Chatham Retail Thrive Zone
- Micro Market Recovery Programs

These economic development investment incentives target communities that have experienced economic challenges but have strong potential for growth, and represent the City's ongoing commitment to reinvesting in this neighborhood.

Chatham has an opportunity to uniquely benefit from these incentive programs due to its existing concentration of unique commercial buildings, including Chicago landmark properties identified in Figure 3.

PURPOSE OF THIS GUIDE

The Chatham Commercial Corridor Design Guidelines are intended to assist owners and tenants of buildings along three commercial corridors in the neighborhood, by providing the following:

- Guidelines for improving existing buildings, with emphasis on the appearance of storefronts, signage, and window displays
- Guidelines for the maintenance and restoration of the upper floors of traditional main street retail buildings
- Recommendations for the retention of single-story Midcentury Modern buildings
- Recommendations for prioritizing vacant sites for infill development

- Identify eligible improvements that could be funded under existing city incentive programs

These design guidelines are intended to **assist property and business owners who may wish to undertake physical improvements to their buildings**, particularly in conjunction with identified city incentive programs.

These design guidelines were informed by local businesses and community organizations, in coordination with the Planning and Design Division of the Department of Planning and Development.

These guidelines are intended to be self-regulated by the local business community and are **not a replacement** for the existing required permit process or of the applications, review process or fees of relevant City of Chicago agencies.

PUBLIC ENGAGEMENT

In 2016, DPD applied for a program offered by the Richard H. Driehaus Foundation that, in partnership with the Congress for the New Urbanism, provides design assistance through community engagement efforts.

These Design Guidelines were developed through this robust community engagement process. A summary of these efforts is available in Appendices A and B.

Participation by community stakeholders was critical to this planning process. Initiated in summer 2017, public engagement included input from more than 100 individuals over the course of three community meetings, a visual preference survey, and several forms of in-person feedback.

This plan also involved engaging the Chatham business community and area stakeholders in a **tactical intervention exercise** along W. 75th Street known as *Dining on the 5*, with the goal of demonstrating how local businesses and stakeholders can enhance the

existing conditions along Chatham's commercial corridors (see Appendix D).

The Chicago Department of Transportation was instrumental in providing input prior to the implementation of tactical interventions on W. 75th Street. Alderman Roderick Sawyer's input was also essential to the process.

As a result of this project, during the summer of 2018, the *Dining on the 5 project* was implemented by the Greater Chatham Initiative again.

The following images depict the successful implementation of a tactical intervention along East 75th Street.



Preliminary sketch of tactical intervention exercise presented to the community



Design team constructing parklets at a local business parking lot



Residents enjoy the outdoor seating on W 75th Street resulting from the tactical intervention

CHAPTER 1: INTRODUCTION & CONTEXT

HISTORY

Chatham, a roughly triangle-shaped community area on Chicago's south side, is bounded on the north by 79th Street, and the east, south and west by rail lines. Originally known as "Mud Lake," early Chatham was primarily swamp and used for duck hunting. In 1860, the first structures in the area were corn cribs, followed by small frame houses built by rail workers (the Illinois Central Railroad ran along the community area's eastern boundary). Historically, Chatham was composed of three neighborhoods: Avalon Highlands, first settled between 1884 and 1895 by Italian stonemasons; Dauphin Park, later called Chesterfield, settled by Hungarian and Irish rail workers; and Chatham Fields, used in the 1880s as a picnic ground. In 1914, a development called Chatham Fields was built on the land, enforcing strict use and development codes of conduct (predating the 1923 citywide zoning ordinance).

Development in the Chatham community was similar to that of the neighboring Greater Grand Crossing community and grew rapidly in the early 20th-Century. In the 1920s many Chatham residents were native-born Americans of Swedish, German and Irish descent. Brick bungalows and small apartment buildings sprung up throughout Chatham, and by 1930 the neighborhood was considered "residentially mature."

Chatham has been home to several notable residents throughout its history, including Mahalia Jackson (the Queen of Gospel music), Eugene Sawyer (former Chicago Mayor), and others. Appendix E provides a more complete historical timeline for Greater Chatham.

Between the 1950s and 1970s, Chatham transitioned from a middle-class white community into a middle-class African American community. More recently, the Chatham area has experienced a population decline. Within a one-mile radius of the study area, the population declined 15% from approximately 569,000 residents in 2000 to around 478,800 in 2010.

STUDY AREA

The Chatham Commercial Corridor Design Guidelines study area is located nine miles south of Chicago's Central Business District, or about 30 minutes by car (see Figure 1). The study area extends along 75th Street from Wabash to Cottage Grove Avenue, along 79th Street from Michigan to Maryland Avenue, and along Cottage Grove from 75th to 79th. The boundary encompasses existing Special Service Area (SSA) #51, 87th/Cottage Grove TIF district, 67th/Wentworth TIF district and the Chatham Retail Thrive Zone (see Figure 3). The District is also within a Neighborhood Opportunity Fund area.

These commercial corridors are connected to downtown by CTA rail with a Red Line station at 79th Street, by car via the Dan Ryan Expressway, and by Metra with stations at 75th

Street (Grand Crossing) and 79th Street (Avalon Park).

EXISTING BUSINESSES

Data collected by the Department of Business Affairs and Consumer Protection (BACP) showed there are approximately 166 active businesses licenses in the area. Each section of the study area has a distinct mix of businesses and orientation: for instance, East 75th Street has a concentration of food-oriented businesses, while 79th Street includes more retail service-oriented businesses, and Cottage Grove Avenue has primarily auto-oriented service businesses (see Figure 2 and Appendix C).

Figure 1. Location of the Study Area within the City of Chicago

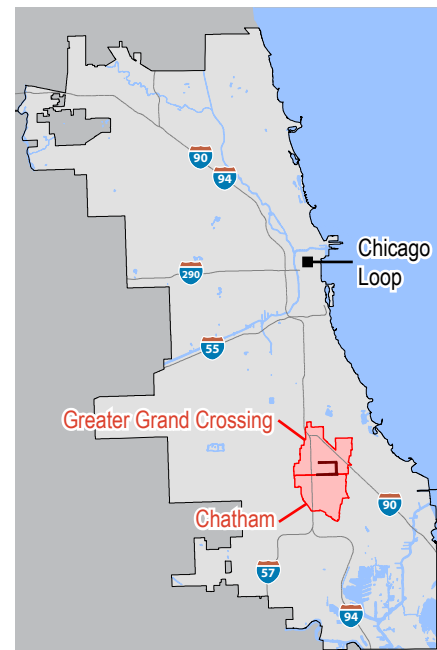

Looking north along Cottage Grove Avenue towards 75th Street (1920s)



View of 75th Street and Cottage Grove Avenue (1930)

Figure 2. BACP Licenses Analysis in the Study Area (2017)

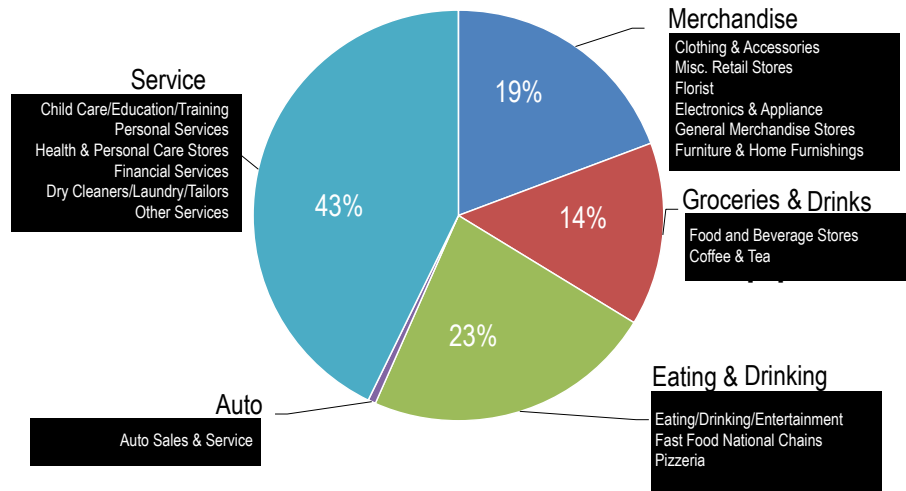
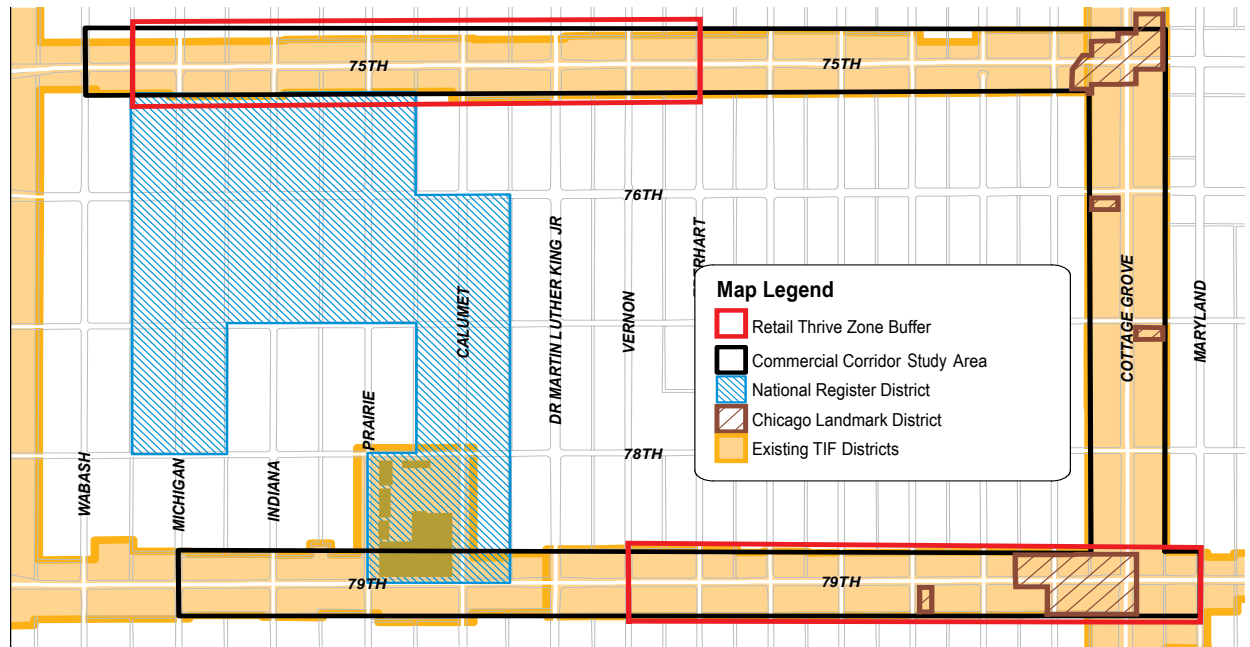

Figure 3. Chatham Study Area



- ① Security systems (cameras and window protection systems)
- ② Overall storefront rehabilitation
- ③ Electric sign and hardware behind the window's storefront
- ④ Facade's repair
- ⑤ Permanent lighting fixtures

Example of a one-story standalone commercial building and a mixed-use multi-story building, depicting potential Neighborhood Opportunity Fund and Retail Thrive Zone eligible items

CHAPTER 2: EXISTING INCENTIVES

NEIGHBORHOOD OPPORTUNITY FUND AND RETAIL THRIVE ZONES ELIGIBLE ITEMS

The Neighborhood Opportunity Fund (NOF) is an economic development tool that receives funds from new development downtown in order to fund catalytic projects within eligible commercial corridors on the City's South and West Sides. Business owners can receive **up to 65% of eligible project costs** through an NOF grant.

Retail Thrive Zones (RTZ) are a three-year pilot program that began in 2017 and focuses on a small number of commercial corridors within these same South and West Side communities, with the goal of providing greater access to capital covering **up to 75% of total project costs**.

WHAT CAN BE FUNDED?

Eligible costs under NOF grants must generally be related to new construction or the rehabilitation of existing buildings. This includes:

- Land acquisition and assembly
- Building acquisition, demolition and environmental remediation
- Security measures
- Roofing, facade repair and mechanical system repairs
- Architectural and engineering fees
- Financing fees (related to securing a loan or other capital)
- Minor site improvements, such as fencing or planters, when a part of an eligible project
- Other soft costs associated with eligible hard costs
- Projects that undertake the construction of new buildings are eligible to receive up to 30% of total project cost, while projects that rehabilitate an existing building may receive up to 50% of the total cost
- Minimum total project cost \$30,000, with a grant minimum of \$15,000

WHAT CANNOT BE FUNDED?

- Residential units or the residential portion of mixed-use buildings
- Minor repairs and improvements, such as painting
- Repairs or improvements that are required to bring a building into compliance with the City of Chicago Building Code
- Support programs or services
- Operating expenses
- Travel expenses

The illustration on page 6 shows additional examples of items that may be eligible for funding under the NOF and RTZ programs. More information is available at <http://neighborhoodopportunityfund.com>.

OTHER CITY & STATE RESOURCES

In addition to the City's NOF and RTZ programs, the Department of Planning and Development administers numerous business assistance and financial incentive programs on behalf of local companies including New Markets Tax Credits, Small Business Loan Program, and TIFWorks. More information on these programs is available at the DPD webpage: cityofchicago.org/city/en/depts/dcd/supp_info/economic_developmentincentives.html

Financial incentives for historic preservation projects fall into four major categories: federal incentives, local incentives, low-interest loans, and grants. The following are some historic preservation incentives for eligible properties:

A **20% Property Tax Assessment Freeze** is available for rehabilitating owner-occupied residential contributing buildings within the South Park Manor National Register District (see Figure 3). This 12-year freeze period requires that the rehabilitation must have eligible expenses equal to or exceeding 25% of the property's fair market value as determined by

the Cook County Assessor, for the year the rehabilitation began.

More information on this and other state-administered incentives are available at <http://www2.illinois.gov/dnrhistoric/preserve/pages/funding.aspx>.

A **preservation easement donation** is a one-time charitable federal income tax deduction equal to the appraised value of the preservation easement, which is a legal agreement that assigns a qualified non-profit organization the right to review and approve alterations to a property for the purpose of preserving it in perpetuity. The property must be a certified historic structure on the National Register of Historic Places, individually listed, contributing to a district, or contributing to a local landmark district. For more information, call Landmarks Illinois, at 312-922-1742.

The **Cook County Class-L Tax Incentive** is a 10-year property tax reduction for rehabilitating a commercial or industrial landmark building (see Figure 3 for Chicago Landmark District). The minimum investment is 50% of the building's assessed value (the total assessed value minus the land value) as determined by the County Assessor. For more information, call the Cook County Assessor's Office, Office of Special Assessment Programs at 312-603-4137, or the Historic Preservation Division of the Chicago Department of Planning and Development at 312-744-3200.

In 1997, Chicago City Council enacted a **Permit Fee Waiver Program** to enable owners of Chicago landmark properties to apply for a waiver of some building permit fees (see Figure 3). Obtaining fee waivers requires prior application and approval by City Council. For more information, call the Historic Preservation Division of the Chicago Department of Planning and Development at 312-744-3200.

CHAPTER 3: DESIGN GUIDELINES

The area's commercial corridors include buildings designed in popular architectural styles from the early 20th Century, including Classical, Renaissance and Gothic Revival styles, as well as structures designed in the Chicago-originated Prairie and Sullivan-esque styles. Chatham's commercial corridors retain many examples of these, particularly along 75th and 79th Streets closer to Cottage Grove Avenue. Buildings at the intersections of these streets—19 in total—were designated part of the Chatham-Greater Grand Crossing Landmark District in 2008.

POTENTIAL PEDESTRIAN STREET DESIGNATION (P-STREET)

In order to maintain the continuity of the multi-story commercial buildings along 79th Street, the area of 79th Street between Maryland and Champlain Avenues could be considered for designation as a **pedestrian street** or "P-Street." This section contains one of the best collections of extant, historic, multi-story, mixed-use buildings in the commercial district and has the opportunity to become a prime area for pedestrian-related activities and revitalized retail uses.

Designation of new P-Streets requires approval by City Council; this zoning change would require coordination between the community, alderman's office, and DPD to implement.

LANDMARKS ILLINOIS RESTORATION RESOURCES INVENTORY

For property owners who need professional services, products, crafts people, and other experts related to the maintenance, restoration, and rehabilitation of older structures, Landmarks Illinois provides a resource that may be helpful:

<http://www.landmarks.org/resources/illinois-restoration-resource-directory/>

1A. CONSIDERATIONS FOR HISTORIC BUILDINGS

For any alterations to buildings within the Chatham-Greater Grand Crossing Landmark District, work and permits must be approved by the Commission on Chicago Landmarks. More information on the Landmark permit review process is available at http://www.cityofchicago.org/city/en/depts/dcd/provdrs/hist/svcs/permit_review.html. For all other buildings in the Chatham commercial corridor area, the following guidelines are meant to assist property owners on rehabilitation best practices:

- Historic elements should be repaired, if possible

- Original design elements that have retained significance in their own right and characteristically define the historic district should be preserved to the greatest extent possible
- New materials should match original ones in composition, design, color, texture and other visual qualities to the greatest extent possible
- Buildings within the district are of a particular time, place and character. Signage should not be uncharacteristic in style, even if that style attempts to create a historic appearance, if that appearance is not characteristic of the district

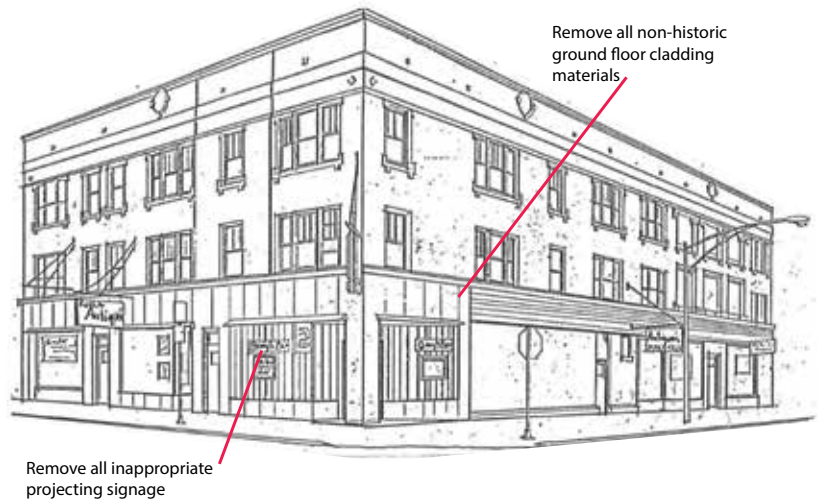

Mixed-use building example BEFORE

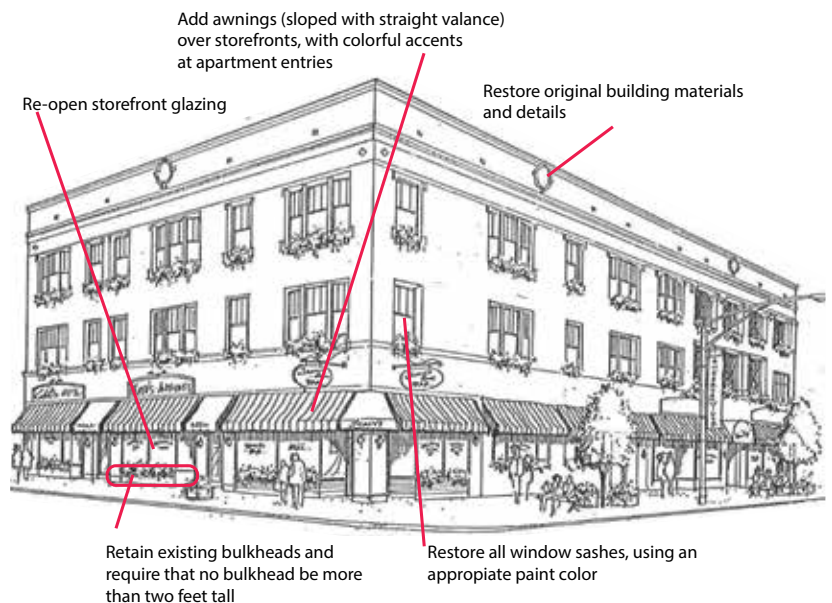

Mixed-use building example AFTER

- Restoration and/or replication of lost elements is encouraged
- All attachments to the facade should avoid damaging historic ornamental features, and be at mortar joints
- Number of attachments should be minimized as much as possible
- Fences, benches, landscaping and other elements should be compatible with the design of adjacent buildings
- Restore and non-abrasively clean original brick and limestone facades
- Restore all uncovered original building materials and facade details
- Restore and/or repaint all original window sashes
- Remove all inappropriate signage, chains and brackets
- Maintain existing building window configuration (both size & scale)

1B. STOREFRONT RESTORATION

- Restore the original size of any filled-in or covered over upper-story window openings and repair or replace windows in "like-kind" to match historic windows
- Ensure that security grills are unobtrusive and explore using other technologies, such as clear protective films for glass, or relocate security grills behind the storefront glazing
- Uncover and restore original piers and lintels
- Retain existing bulkheads and require bulkheads to be no more than two feet tall

1C. MAINTAIN AND ENHANCE EXISTING MIDCENTURY BUILDINGS

Between the 1950s and 1970s, three distinctive, single-story, Midcentury Modern commercial buildings were constructed: the Pride Cleaners building at 558 East 79th Street, Lem's Bar-B-Q at 311 East 75th Street, and a currently unoccupied building at 75 East 75th Street. This architecture style is unique in Chatham and in selected areas in Chicago and its preservation is encouraged. The three buildings are located at 311 E. 75th Street (currently Lem's Bar-B-Q), 558 E. 79th Street (currently Pride Cleaners), and 75 E. 75th Street (currently Pink Diamond).

The original configuration for this architectural style usually includes a standalone building linked with automobile access and a pole sign. The retention and restoration of historic pole signs in the district is encouraged. With the exemption of these three Midcentury Modern buildings, new pole signs are not encouraged within these corridors. For other existing pole signs along these corridors, they should eventually be removed or transitioned to monument signs.

The images on page 10 depict the three Midcentury Modern buildings located within the Chatham commercial area as well as two monument signs also in the area that showcase the same architectural character.

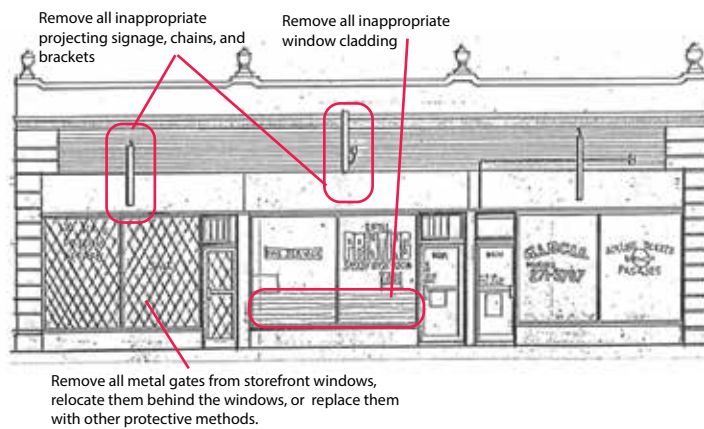

One-story commercial building example BEFORE

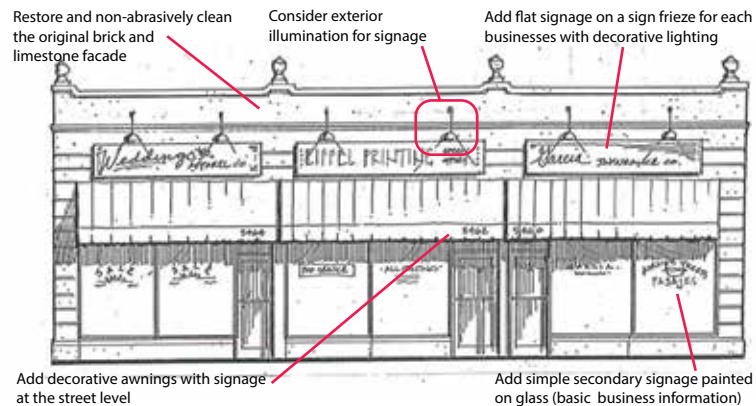

One-story commercial building example AFTER



Pride Cleaners building - 558 E. 79th Street - Photo By Lee Bey



Lem's Bar-B-Q building - 311 E. 75th Street



Pink Diamond building - 75 E. 75th Street



Existing pole sign at Pride Cleaners



Existing pole sign at Lem's Bar-B-Q

1D. POTENTIAL DEVELOPMENT SITES AND NEW CONSTRUCTION

During the planning process, DPD staff collected information on the area's vacant lots and city-owned properties, as shown in Figure 4. While there are several vacant sites within the district, two in particular have been identified for prioritization, due to:

- 1) Size and location
- 2) Disruption of commercial corridor continuity
- 3) Lack of pedestrian access

The following guidelines are meant to inform developers in best practices for new construction within the Chatham commercial corridor area:

- Use side streets and alleys for access whenever possible
- Corner buildings should embrace the corners and minimize any setbacks from the property line
- Design buildings and site plans to minimize the number of driveways (curb-cuts) needed
- Construct loading zones in the rear or on the side of buildings
- Shared parking facilities to minimize the number of curb cuts onto 75th and 79th Streets.
- Ensure that curb-cuts not exceed more than 25 feet, as specified in the Chicago Zoning Ordinance

2. SIGNAGE DESIGN RECOMMENDATIONS

All new signs and refacing of existing signs require a permit and will need to meet the zoning and building codes. For buildings in the landmark district, signs will need review and approval by the

Commission on Chicago Landmarks. More information on the City's sign permit process is available at:

<https://www.cityofchicago.org/city/en/depts/bldgs/provdrs/permits/svcs/sign-permits.html>

The following design guidelines are based on community feedback (see Appendices A and B) and general best practices to guide owners and tenants wishing to improve their signage.

CONTENT

- Keep it simple – store name, logo, and hours of operation
- Avoid electronic message signs
- Avoid more than one sign per business
- Avoid flashing or similar distracting signs (strobe lights are prohibited by the zoning ordinance)

Remove all inappropriate projecting signage, chains, and brackets

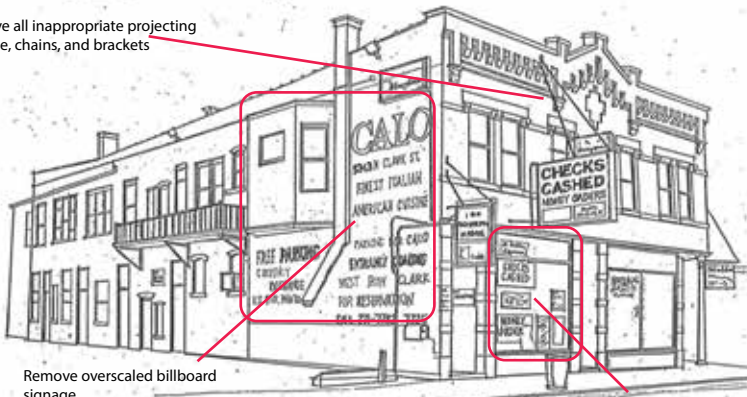

Remove overscaled billboard signage

Remove excessive window signage

Multi-story mixed-use building example BEFORE

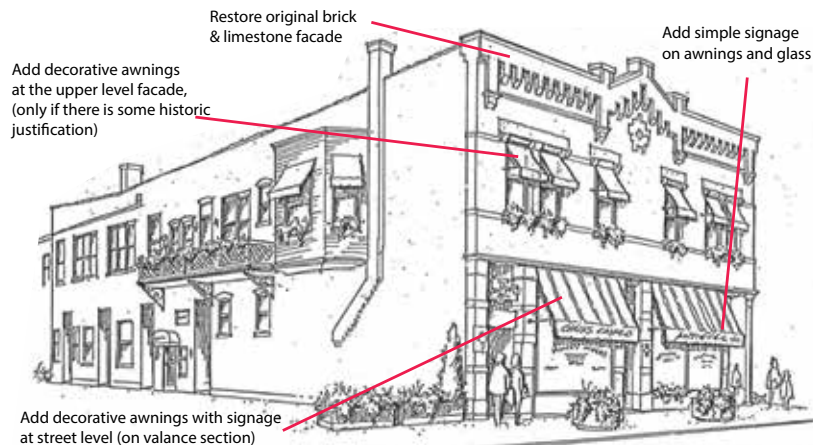

Restore original brick & limestone facade

Add decorative awnings at the upper level facade, (only if there is some historic justification)

Add simple signage on awnings and glass

Add decorative awnings with signage at street level (on valance section)

Multi-story mixed-use building example AFTER

Figure 4: Vacant Land by Ownership in the Design Guidelines District Area

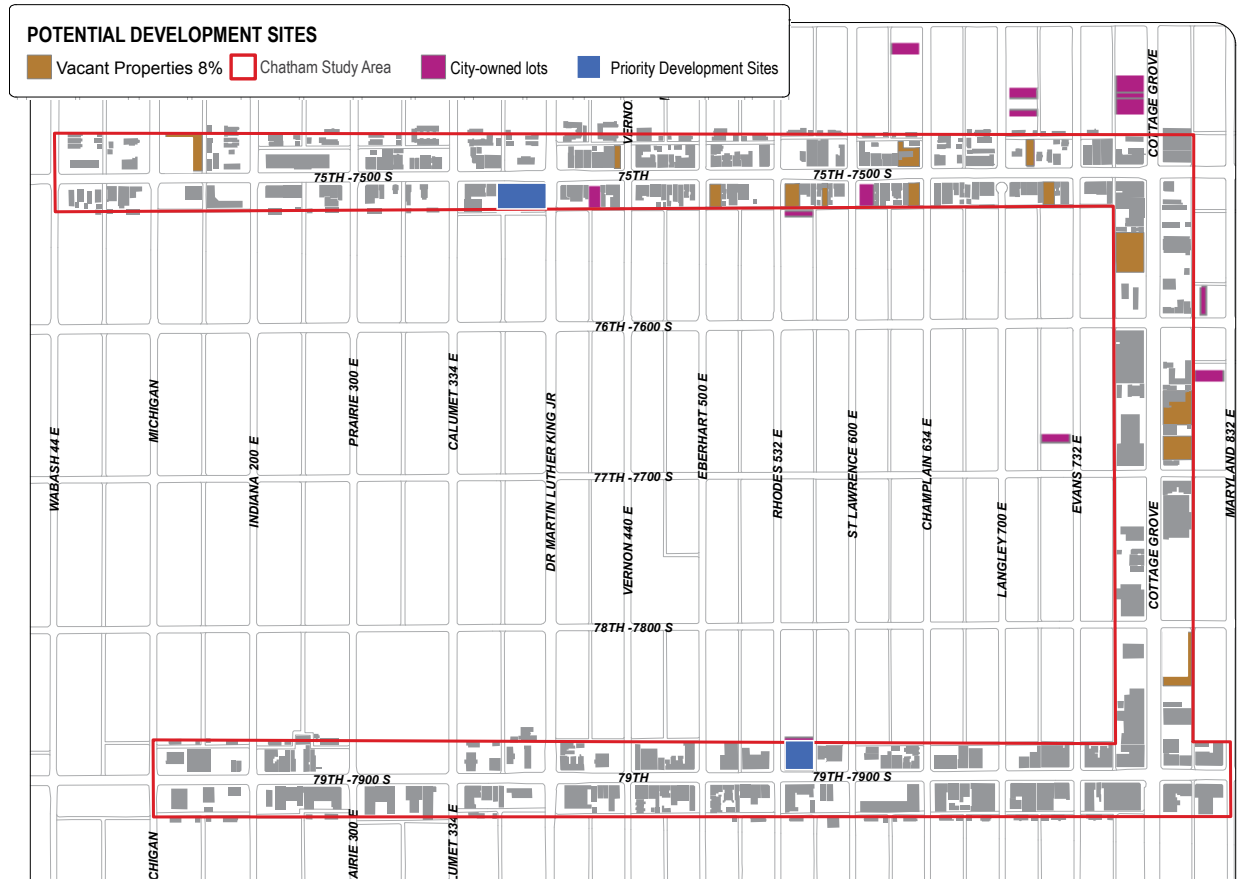

Vacant lot at the southwest corner of 79th Street and King Drive



City-owned vacant lot on 75th Street



Existing underutilized planters on 75th Street



Example of a high visibility crosswalk



Preliminary proposal for development site #1

SITE 1 - Approximately 24,100 sq. ft. located at the southwest corner of King Drive and 75th Street, the easternmost lot is zoned B1-1, while the western half is zoned C1-1. Redevelop the vacant lot located at the southwest corner of King Drive and 75th Street to include a commercial or mixed-use building that embraces the corner with the required parking in the back of the property.



Preliminary proposal for development site #2

SITE 2 - Approximately 12,300 sq. ft. located at 544 E. 79th Street, zoned B3-2. Based on its characteristics, the site could be redeveloped with a mixed-use building that includes commercial on the ground floor, and residential or office space above. Currently, the site accommodates a temporary vendor structure (i.e., Boombox) through the City's Retail Thrive Zones program, a three-year pilot program aimed at creating and supporting inclusive, vibrant commercial corridors in eight targeted neighborhoods. Boomboxes are prefabricated micro-retail kiosks that provide short-term pop-up retail opportunities for local entrepreneurs.

- Individual letters may sit in on a railway or channel to minimize number of attachments to facade

(decorative brickwork, cut limestone, terracotta, etc.)

PERMITS AND PUBLIC WAY USE

Any sign, awning or canopy that extends over the public way requires a Public Way Use Permit and annual fees. More information on this permit process and annual fee structure are available in Appendix F.

Additionally, any new sign requires a permit from the Department of Buildings. More information is available at: <https://www.chicago.gov/city/en/depts/bldgs/provdrs/permits/svcs/sign-permits.html>

AWNINGS

- Use straight awnings with a hanging “valance” to provide potential area for signs
- Awnings should extend between 48” to 60” from the face of the building
- Awnings should provide a minimum clearance of 7’-6” over the sidewalk
- Awnings are great for providing shade for the store’s merchandise and to protect pedestrians from inclement weather
- Awning structure should be made out of metal and ideally be retractable to avoid exposure to the elements when it is not needed
- Avoid vinyl materials, which can easily deteriorate
- Position awnings so as not to conflict with any architectural details

FLOWER BOXES

Local businesses could work together to develop a standard flower box for purchase by individuals, and create an annual flower box building awards program to maintain interest and engage the community.

CONSTRUCTION AND INSTALLATION RECOMMENDATIONS

- Building tenant or owner will be responsible for signs, permits, power sources, connections and installations
- Metal sign materials, fastenings and clips of all types should be hot-dipped galvanized iron, stainless steel or brass.
- Raceways, transformers, ballasts, P.K. housings, conduit, boxes and other wiring should be concealed from public view
Sign components will need to comply with code requirements

3. ENHANCEMENTS TO THE PUBLIC WAY

In addition to the design recommendations for buildings and storefronts, and as result of successful testing the temporary outdoor seating strategies, business owners are encouraged to integrate parklets and additional outdoor options into their establishments. As of 2018, businesses with a valid Retail Food Establishment License may apply for a Sidewalk Cafe Permit to serve food outside their restaurant on city sidewalks.

Signage should not be placed or block existin architectural details, windows, cornices, or other features

Signage should not be placed on the building above the first story sign frieze.

Signs located on the upper floors can be stenciled to the window glass.

Flat signs (either painted or individually cut-out letters) on the building sign frieze, which is horizontal flat band above the store windows

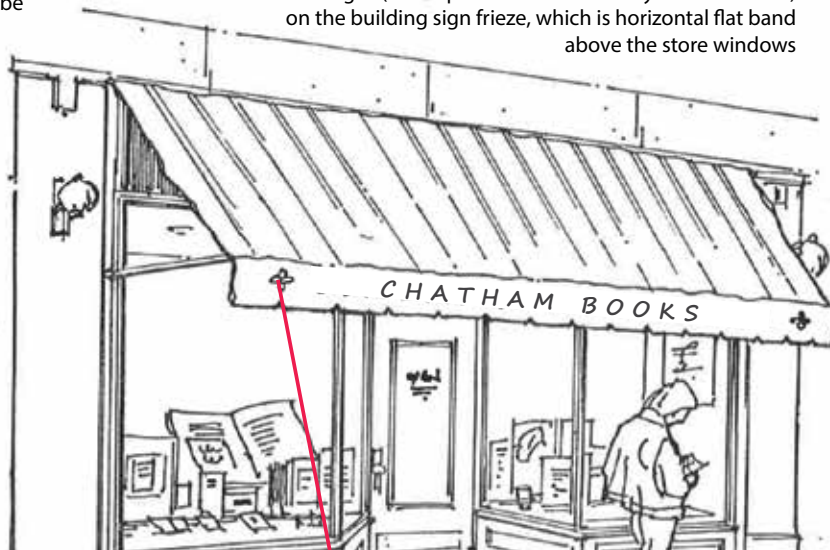

An awning valance can be an excellent place to advertise a business’s name, address or services (keep it simple)

Signage recommendations for an existing storefront

Make way for People (www.makewayforpeople.org) is a placemaking initiative that supports public-private partnerships to transform the public way through creative temporary tactical improvements and cultural programming, such as People Spots (parklets), People Streets, People Plazas and People Alleys. While sidewalk cafés, which require a sidewalk café permit, allow private businesses to serve on public sidewalk space, People Spots are temporary platforms in the parking lane of streets that are open to the public and are not designated for use by a specific businesses. By expanding the sidewalks, they provide additional public outdoor space for pedestrian use during the warmer months. People Spots have been found to increase pedestrian foot traffic and help promote economic development.

Some areas are not ideal for sidewalk café seating. Along 79th Street, for example, the existing sidewalks on both sides of the street are 11 feet wide, which makes them less appropriate for sidewalk seating. Per Sidewalk Café permit requirements, a minimum of six feet must remain clear for pedestrians to walk and two feet of clearance (minimum one foot for sidewalk cafés) must be maintained from the curb.

Interested businesses facing a narrow sidewalk are encouraged to locate outdoor cafés on side streets with wider sidewalks, like at 79th Street and Rhodes Avenue.

MAINTENANCE REQUIREMENTS

For streetscaping improvements including parklets, above and in-ground planters, and hanging baskets, the City requires that a local community organization or SSA sign a maintenance agreement stating they

will be responsible for maintenance prior to construction. This is a standard agreement that commits the community to conducting a variety of tasks, including, but not limited to:

- Removal of litter and debris
- Weeding
- Plant replacement
- Basic upkeep of plants
- Watering (if necessary)
- Reporting damage or vandalism
- Pavement sweeping and cleaning
- Reporting broken or unstable pavers

For temporary tactical improvements through CDOT's *Make Way for People* program, the City requires signature of a use agreement for the proposed project location.

MAKE STREET CROSSINGS SAFER FOR PEDESTRIANS

Making the overall Chatham commercial area more pedestrian-friendly is an important aspect of creating a thriving commercial corridor.

The following are a few low-to-high cost interventions that could be installed or applied to improve overall pedestrian access within the area. Any proposed improvements on the right-of-way will require allocating funding resources and coordination with various city agencies including the Chicago Department of Transportation and the Chicago Transit Authority.

Window displays and signage should not block the view into the store, in order to help advertise the business content and merchandise better.

Transom windows should not be obstructed or blocked by drop ceilings



Typical commercial storefront

Awnings should be located entirely within the storefront area and should not cover piers of columns

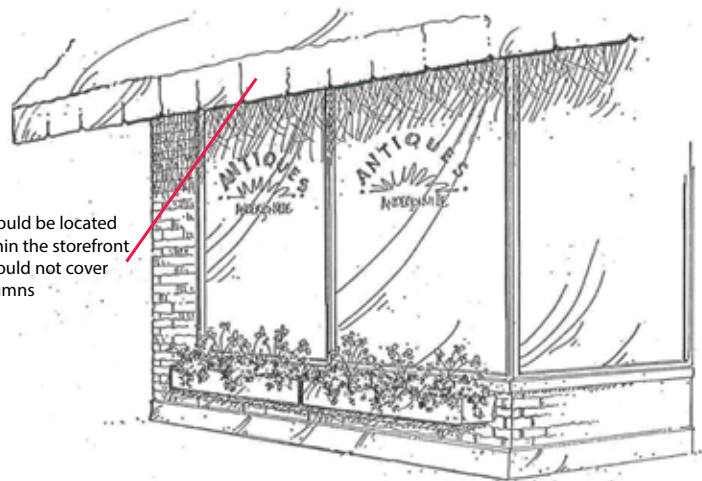

Typical commercial storefront

For additional reference, Figure 5 shows the potential location of improvements: these intersections were selected based on the concentration of existing businesses, major streets, or presence of institutional uses, such as the Whitney M. Young Library. These intersections also have the highest number of pedestrian injuries between 2009 and 2014 (source: www.chicagocrashes.org). The Cottage Grove corridor from 75th to 87th Streets has also been identified as a High Crash Corridor by the Vision Zero Chicago Action Plan.

SHORT-TERM IMPROVEMENTS

- Investigate the installation of in-street “stop for pedestrian” signs at key intersections throughout the corridor to alert motorists to pedestrian zones and facilitate pedestrian movement

Relocate existing planters along 75th Street that are randomly distributed to locations within the district areas businesses are concentrated to augment areas that already have higher pedestrian activity

- Consider the implementation of creative temporary tactical improvements through CDOT’s *Make Way for People* program. Temporary installations could include parklets, movable planters or furniture, and artistic installations (see Appendix D)
- Re-stripe and install upgraded crosswalks

MEDIUM-TERM IMPROVEMENTS

- Increase the amount of trees along 75th Street (particularly the north side blocks between Indiana Avenue and King Drive), and along Cottage Grove Avenue (both sides of the street). Creating additional landscaping on these rights-of-way will improve the aesthetic appearance of the district, provide a buffer for pedestrians on the sidewalk, provide shade and reduce heat-island effect

- Install curb-extensions (bulb-outs) where feasible to create additional pedestrian space (depending on the conditions, a curb extension could be 7’ wide and 20’ to 30’ long)
- Install pedestrian refuge islands along Cottage Grove Avenue, where feasible, ideally at the crossings of main intersections (see Figure 3)

LONG-TERM IMPROVEMENTS

- Investigate the installation of stormwater management systems where feasible, which could include permeable pavers or bioinfiltration systems such as infiltration planters or bioretention parkways along the public right-of-way
- Consider shared bike lanes where feasible

Figure 5: Main arterial streets and pedestrian injuries map

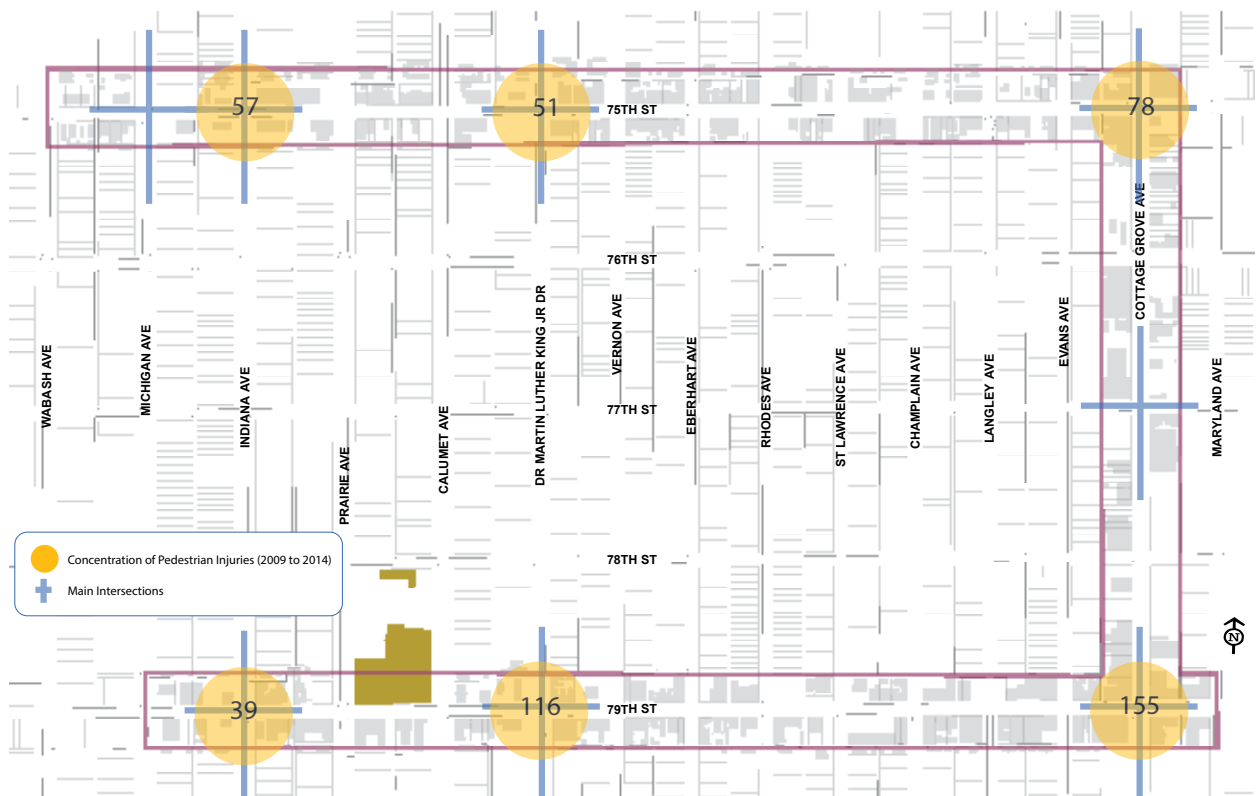



APPENDICES



APPENDIX A: COMMUNITY ENGAGEMENT PROCESS

During the summer of 2017, three community meetings were held in the Chatham Commercial Design Guidelines area and approximately 80 people attended. The following is a brief description of the community feedback provided at each meeting.

MEETING 1, JUNE 29TH: VISUAL PREFERENCES

Attendees were lead through a visual preference survey by Farr Associates (Appendix B) in which they were asked

to provide feedback on design options for storefront improvements, including awnings, metal grills, transparency, business experience, signage types, etc. The responses also triggered a lively conversation about the preferred image of the corridor.

MEETING 2, JULY 27TH: DINING ON THE 5 RECAP

Attendees provided their thoughts on the tactical intervention event (see Appendix D), Some highlights included: outdoor seating makes sense; additional foot traffic helped increase sales revenue by 30%; increased activity made the area feel alive, vibrant, and safe once again.

Partnering organizations and individuals highlighted the need to streamline processes for existing City programs and permits that enable small business owners to add features such as outdoor seating.

MEETING 3, AUG. 18: FINAL GUIDELINES

The third meeting's presentation included an overview of the preliminary design recommendations as well as a quick introduction to the City's permitting process for including signage for business and residents in Chatham.



I WISH THIS WERE...

- A worship center
- A basketball court with seating and trees
- Game room
- Community center
- A safe place for kids to come and play
- Kids community center
- Trade school
- Soup kitchen
- Free counseling center for children and adults to attend to help cope with violence
- Tech lab
- Community center
- Youth development center
- Center for the community
- Poetry center
- Community outreach
- Basketball courts
- Tennis courts
- Vegetable garden
- Fitness center
- Bowling alley
- A refreshing oasis
- Counseling center
- Corner store
- Community center
- Boys and girls club
- Candy store
- YMCA
- Sports center
- Shelter
- Youth center
- Nail shop
- Tech center
- Housing for the homeless
- Pool/game lounge
- A park
- A beer garden
- Cultural center
- Basketball court
- A park for children
- Create a community garden to encourage organic food choices
- Playground
- Farmers market
- Education center

APPENDIX B: RESULTS OF VISUAL PREFERENCE SURVEY (JUNE 29, 2017)

The following pages detail the results of the visual preference survey conducted by Farr Associates with Chatham residents, businesses and other stakeholders on June 29, 2017.

Are **blade signs** appropriate for Chatham businesses?

- A. Yes
- B. No
- C. Unsure

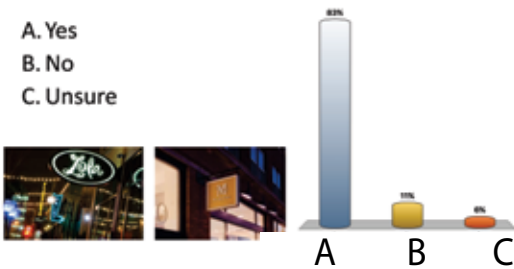

BLADE SIGNS



Are **painted signs** appropriate for Chatham Businesses?

- A. Yes
- B. Yes, but only if they are kept simple
- C. No
- D. Unsure



PAINTED SIGNS



What type of **lighted sign** do you prefer?

- A. Front-lit
- B. Back-lit (non-blinking)
- C. Both
- D. Neither



HOW TO LIGHT SIGNAGE



Do you prefer **façade signs** or **awning signs**?

- A. Façade
- B. Awning
- C. A mix of both
- D. Unsure

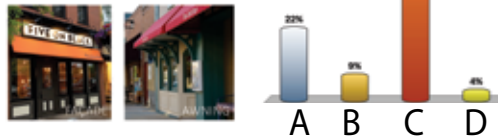

FAÇADE SIGN



AWNINGS



Which level of window coverage is acceptable for Chatham Businesses?

- A. 90%
- B. 50%
- C. 20%
- D. Unsure

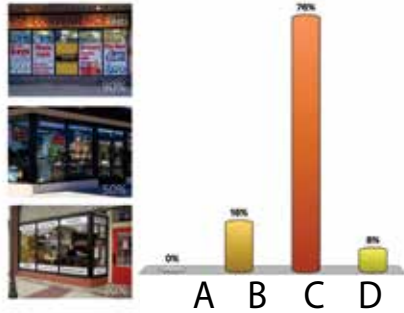

WINDOW COVERAGE



What is your attitude toward outdoor seating?

- A. I love it and want more!
- B. It's too hot in the summer.
- C. I like it, but not on 75th or 79th Street.

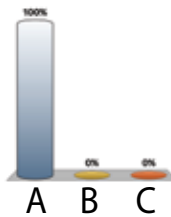

OUTDOOR PARKLET SEATING



Do you prefer consistent signage or varied signage for Chatham businesses?

- A. Consistent
- B. Varied
- C. Unsure

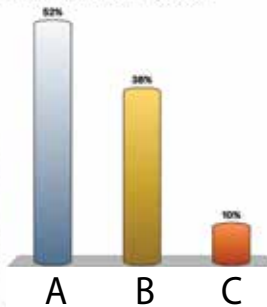

CONSISTENT SIGNAGE

VARIED SIGNAGE



What kind of dining experience do you want more of Chatham?

- A. Fine table dining
- B. Casual table dining
- C. Counter/bar seating
- D. 'ALL' by hand polling (90%)



COUNTER AND BAR SEATING



FINE TABLE DINING



CASUAL TABLE DINING



Do you prefer take-out or dine-in restaurants in Chatham?

- A. Take-out
- B. Dine-in
- C. Both

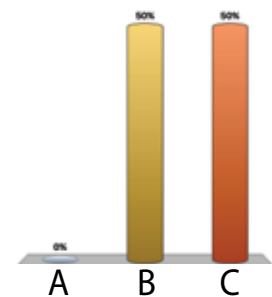

TAKE-OUT



DINE-IN



APPENDIX C: SUPPLEMENTAL INFORMATION FROM EXISTING CONDITIONS ANALYSIS

Figure C.1: Breakdown of Business Licenses along the 75th, 79th, and Cottage Grove Corridors, 2018

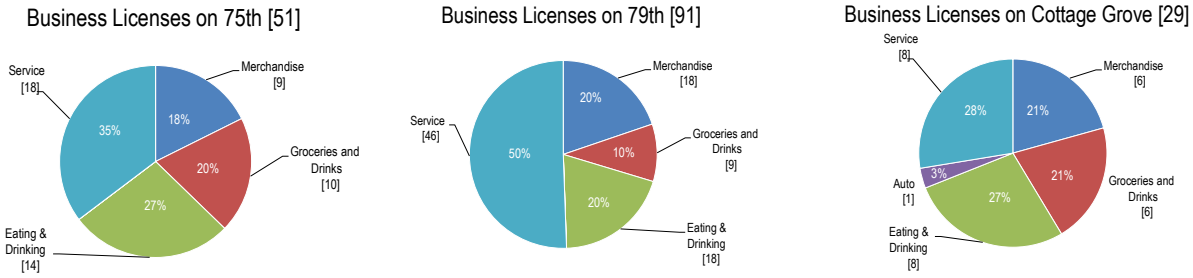

Figure C.2: Number of Establishments in Study Area by Business Category, 2018

Business Description	Design Guidelines Area	On 75th St	On 79th St	On Cottage Grove	Type
Clothing & Accessories	11	4	6	2	Merchandise
Child Care/Education/Training	5	2	3	0	Service
Personal Services	46	10	30	6	Service
Eating/Drinking/Entertainment	33	12	16	7	Food
Misc. Retail Stores	3	0	1	2	Merchandise
Food and Beverage Stores	23	9	9	6	Grocery
Florist	2	1	0	1	Merchandise
Electronics & Appliance Stores	8	3	5	0	Merchandise
Health & Personal Care Stores	4	0	4	0	Service
Financial Services	5	2	3	1	Service
Fast Food National Chains	4	1	2	1	Food
Coffee & Tea	1	1	0	0	Grocery
Dry Cleaners/Laundry/Tailors	7	4	3	0	Service
Auto Sales & Service	1	0	0	1	Auto
General Merchandise	6	1	4	1	Merchandise
Furniture & Home Furnishings	2	0	2	0	Merchandise
Other Services	4	0	3	1	Service
Pizzeria	1	1	0	0	Food
Totals	166	51	91	29	

Land Use Summary

Figure C.3 shows land use in the Chatham Commercial Design Guidelines area in 2018.

More than 70% of the district is designated as commercial and retail uses. There are few exclusively residential buildings within the district, however, many commercial buildings have residential units on upper floors.

Institutional uses comprise 14% of the area, including the Whitney M. Young Regional Library, Martha M. Ruggles Elementary School, 6th Ward office, US Post Office, Fire Station Engine #122, and several places of worship.

Vacant land currently accounts for 8% of the overall land area. Sites are scattered through the district, but there is a concentration of vacant lots along Cottage Grove Avenue.

Figure C.3: Existing Land Use, 2018

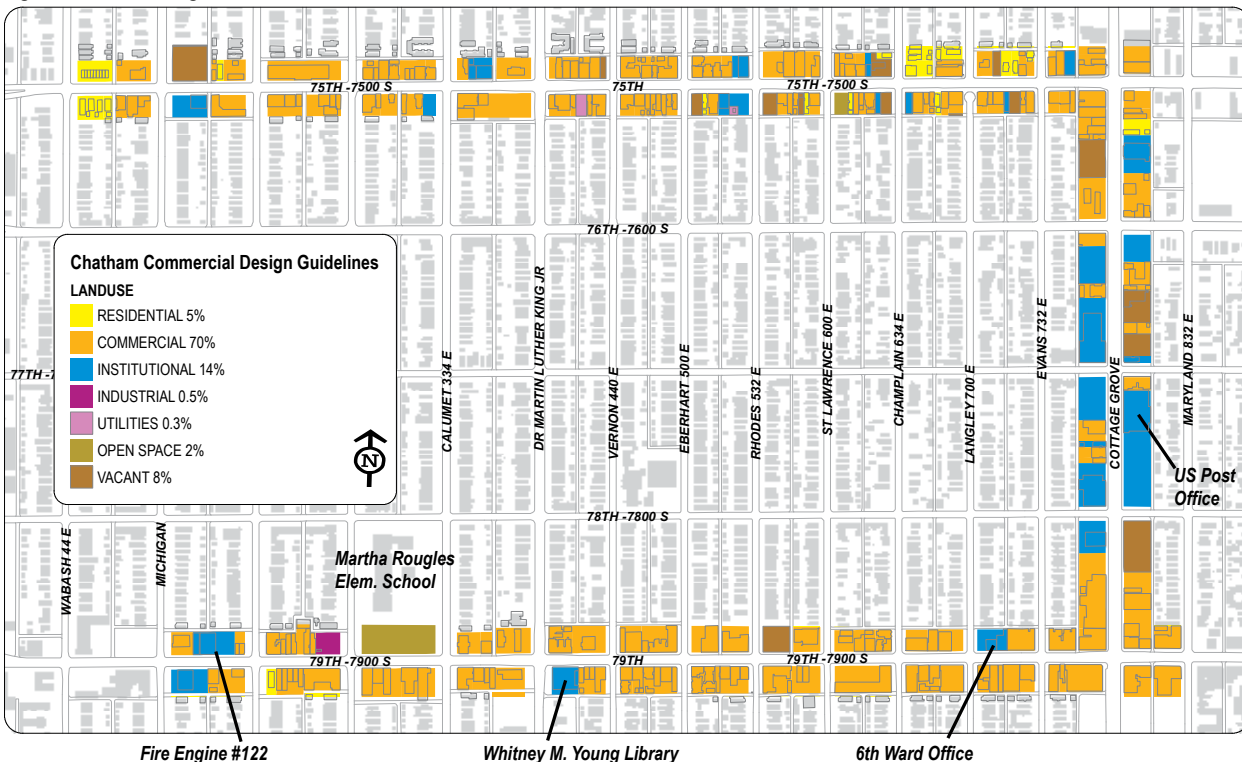
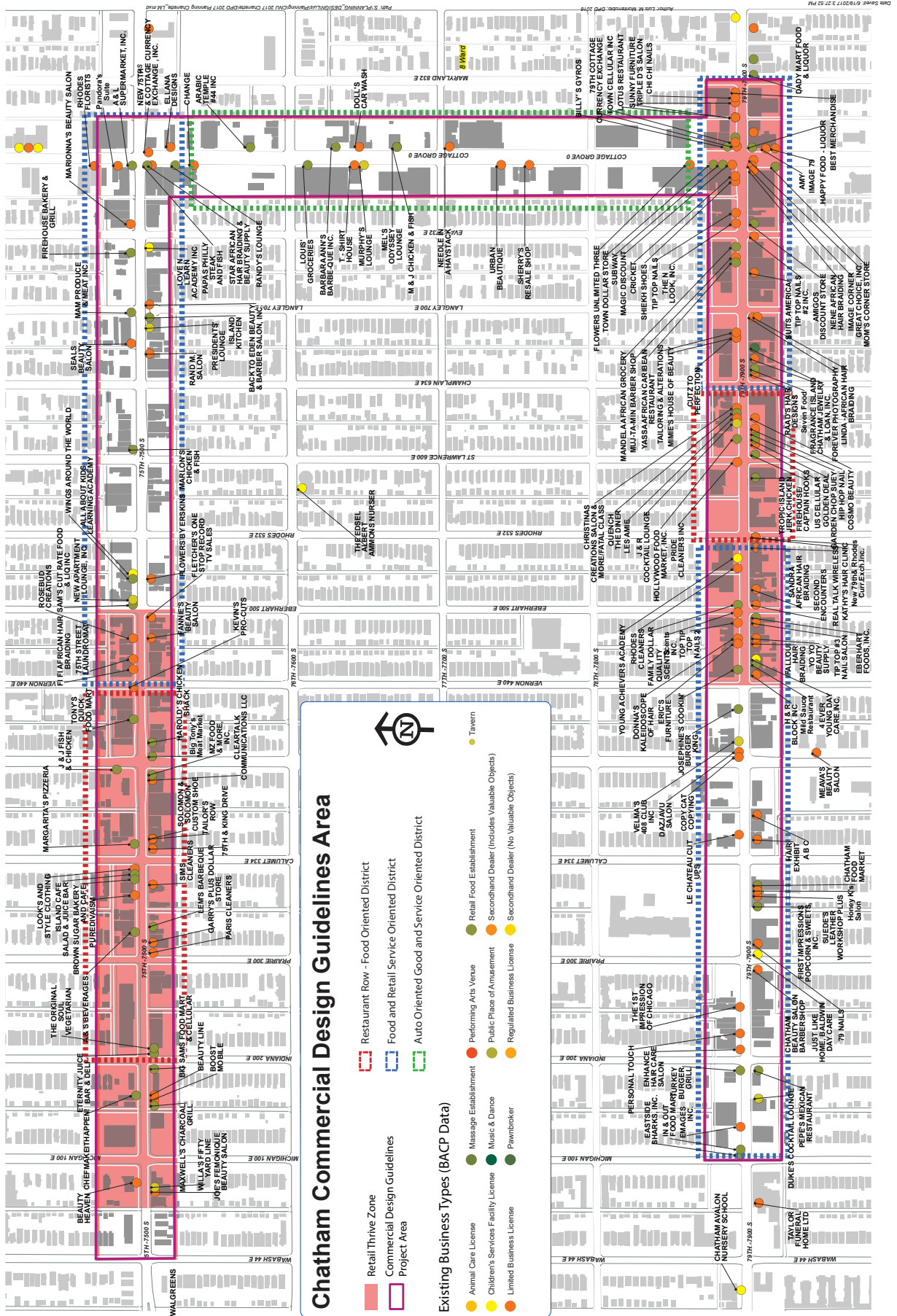

Figure C.4: Inventory of Existing Businesses in the Design Guidelines Area in 2018



APPENDIX D: TACTICAL INTERVENTION

DEFINITION

Tactical Intervention refers to using short-term, low-cost physical interventions in the urban landscape with the goal of proving the success of new concepts and catalyze long-term change. In the context of this study, it was intended to test ideas on:

- How to attract new customers to local businesses within a retail district for the short term
- Give business owners an appreciation of the potential financial benefits of providing outdoor seating
- Put a spotlight on a specific retail district to get it on the “radar” of residents in the rest of Chicago
- Explore both near-term and long-term improvements to the public way to increase pedestrian friendliness and improve safety for all users

DINING ON THE 5 EVENT

Stakeholders and planning staff organized a temporary low-budget tactical intervention event the weekend of July 21 - 23, 2017, where hundreds of community residents and regular customers helped to reactivate the street.

The event, known as “Dining on the 5,” incorporated outdoor seating, parklets, live music and other special offers from participating local businesses along Chatham retail corridors. These interventions are identified on the map below.

PLANNING

The planning process began more than two months before the event and included several coordination meetings among the planning team, CDOT, community groups, and the Alderman’s office.

Tasks undertaken included:

1. Assemble a team
 - Community organizations
 - Local alderman
 - Designers
 - Funders
 - City agency partners
2. Develop a plan
3. Identify locations (3 months before event)
 - Concentration of pedestrian-oriented businesses
 - Enough space on the sidewalk (or on private space adjacent to sidewalk) to install temporary elements in the public way. A 6’ walking path must be maintained
- Low to moderate level of auto traffic

- Limited number of parking lots, curb cuts and vacant lots
- If in the public way, contact CDOT to discuss the project, location and permitting requirements.
- Meet with CDOT on plans for street improvements prior to tactical event and to make sure no work is planned which could disrupt the event

4. Engage the community (5 months before event)

5. Reconvene with the team

Focused Build Day tactical interventions became successful as a public engagement tool and test for new ideas; the project was ultimately extended by the Mayor’s Office through Labor Day.



Dining on the “5” event poster

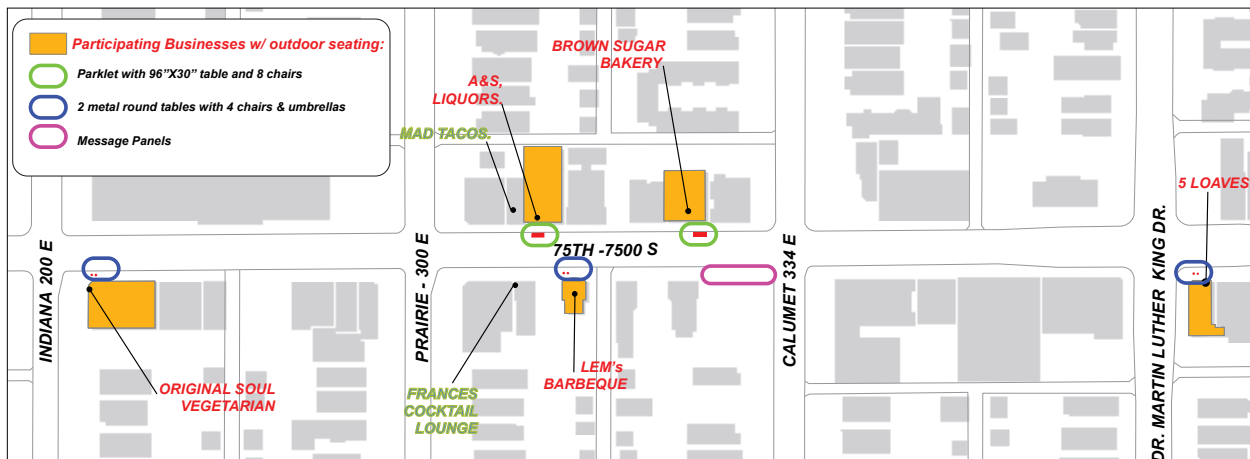

Map showing location of tactical interventions for the event

CONSTRUCTION

Parklets, outdoor seating, planters and message panels were constructed over the course of 2 days by the design/planning team and dedicated community volunteers.

Everything was assembled on the parking lot of a participating business, and a rented storefront secured by the Greater Chatham Initiative.



Design team constructing parklets at A&S Beverages



Volunteers assembling and painting new mobile planters for participating businesses



Finished planter with local school art's project, ready to be moved to local restaurant

IMPLEMENTATION

The proposal initially included three local businesses. However, interest within the business community grew quickly and, by the end of the first week of coordination work, the event had four additional businesses and an additional sponsor came forward.

The results of implementing the tactical interventions included hundreds of people attending the

event and local businesses reporting an average **30 percent increase in sales**. Additionally, nearby businesses that are usually closed over the weekend were opened, and benefited from the additional foot traffic. *Dining on the 5* was repeated again in 2018, with similar success.



Customers sitting at the A&S Beverages' parklet



Live music on 75th Street



New customers enjoying the outdoor seating and planters at 5 Loaves restaurant



Outdoor seating at Brown Sugar Bakery



Outdoor seating and planters at 5 Loaves restaurant

PARKLET CONSTRUCTION MATERIALS

The following pages illustrate how parklets for the *Dining on the 5* event were constructed, but these materials and instructions do not conform to CDOT's People Spot design standards, and any future installations should be coordinated with CDOT and adhere to their guidelines available at:

<http://chicagocompletestreets.org/wp-content/uploads/2016/01/MWFP-People-Spot-Standard-Design.pdf>

<http://chicagocompletestreets.org/wp-content/uploads/2016/01/People-Spot-Design-Assembly-Manual-2.pdf>

OSB Plywood (Oriented Strand Board)

2 to 4 sheets of 1/4 in. x 4 ft. x 8 ft. (example: Model # 300985 Internet #100025804 Store SKU #300985 - These will be used for the floor and seating surface for benches.

One may wish to put 1/8" hardwood subfloor on top for a nicer surface finish as OSB is a bit utilitarian. The tops of any floor surface will need to be sealed with a water-based deck sealer



Block Pallets (11 per parklet)

It may be possible to get free pallets from local grocery or other stores. Home improvement stores no longer make these available for free. Pallets can also be purchased directly from pallet recyclers. Pallets come in two common sizes 48" x 48" and 48" x 40". The square ones form the base for the parklets, while the others are used for the sides.



Common Board

1 in. x 6 in. x 8 ft. Premium Kiln-Dried Square Edge Whitewood Common Board (you'll need at about 5 per parklet).

These are used to tie the pallets together (forming a top rail), to fill the open sides of the side pallets, and to shim the floor pallets where they meet the curb, and as inserts within the pallets to support flower boxes.



Utility Panel

(Common: 1/8 In. x 4 Ft. x 8 Ft.; Actual: 0.106 in. x 48 in. x 96 in.) This may be added on top of the OSB panels for a more pleasant top surface. The top surface will need to be painted with a water based deck sealer. This may also be used to span between the parklet and the sidewalk to create a seamless for a larger dining area



Wood Screws

Power Pro #8 x 1-1/4 in. Star Flat-Head Exterior Wood Screw (1 lb.-Pack) Model # 48595 \$9.98 each - These are used to tie pallets and thinner wood member together.



#10 3-1/2 in. Star Flat-Head Wood Deck Screws (1 lb.-Pack) \$6.82 each - These are used when need to connect thicker wood items together (such as attaching 2 x 4s to each other).



Water based deck sealer

1 gal. Deck Plus Natural Clear Transparent Waterproofing Wood Finish.



Flexible Posts

3-foot tall flexible protective bollards shall be installed in 10-foot on center intervals 6 inches from the face of the parklet along the full length of each parklet. The outside edge of the bollards should not extend past the inside of the parking lane line. (sample product from Uline).



Car stops

6 foot long car stops. These will be installed at both ends of each parklet at least two feet from the sides.



Reflective object markers

(OM-3R) shall be mounted on both end caps of each parklet. The mounting height from the street surface to the bottom of the object marker should be a minimum of 4 feet.



PARKLET ASSEMBLY

Place four (4) pallets against curb and next to each other. Shim with 1" x 6" board under the pallets within the street's gutter pan to level the ground parklet surface. This is necessary due to the crowning of a typical street

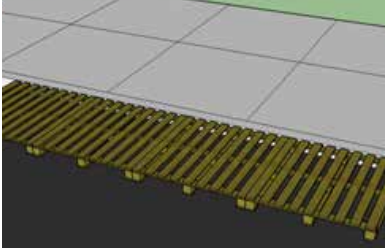

Lay OSB panels over the ground pallets. Leave these panels unfastened for the moment. You'll need access to the floor pallets in order to attach the wall pallets

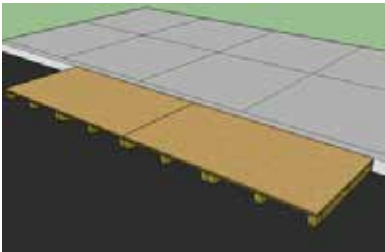

Place six (6) 40" x 48" pallets to form the front (street-facing) and sides (end caps) of parklet. Orient the pallets horizontally so they roughly the same length as the floor pallets.

Block pallets vary between 'horizontal' and 'vertical' deck boards. You may want them to be consistent (all horizontal or vertical) or mixed.

Screw the OSB panels to the floor pallets. Set the end cap pallets 3/4" inches back from the street-facing pallets (as shown in figure 4)

Center the four front vertical pallets on the center point of the horizontal pallet surface. This will likely leave a gap between the front vertical and side vertical pallets. The gap should be roughly 3/4" from the front vertical pallets, allowing a 1" x 6" support to close off the open end of the end cap pallet (facing the street).

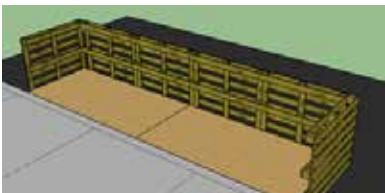

If there is sufficient room on the sidewalk a utility panel may be added to expand the dining area (at the full 8 feet if there is room or less if necessary). These boards will need to be anchored into the sidewalk with concrete anchor screws

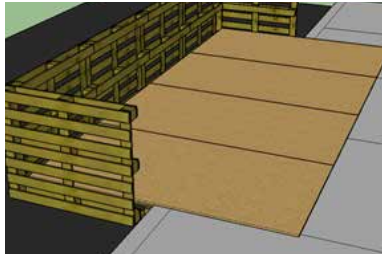
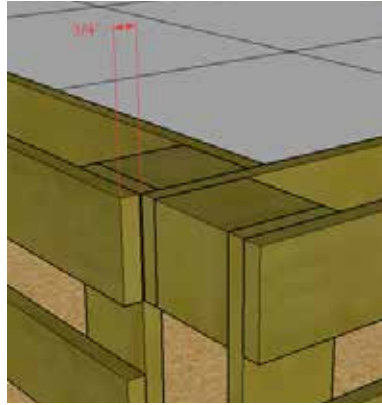

Cut one 40" x 48" pallet in half using a circular saw or table saw. Screw each half pallet into the middle support of the end cap pallet and street-facing pallet. Add a 1x6 board, acting as a chair leg, to support projecting end of bench (as shown in Figure Cut OSB board to covet top of each bench.

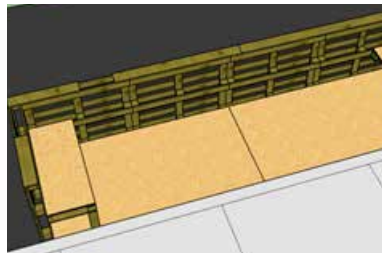

Use a 1" x 6" board to create a finished top surface for the parklet. These pieces should be of appropriate length and spacing to fasten the pallets together by spanning the seams between adjacent

street-facing pallets. Top pieces on the end cap pallets should extend 3/4" beyond the end cap pallet (toward the sidewalk, see figure 9) to allow for a vertical 1" x 6" board to close off the open side of the end cap pallet. Leave openings between top boards (at an interval of your choosing) to accommodate flower boxes. To support the flower boxes, cut 1x6 boards, to act as shelves. These can be wedged between the pallet openings. Screw through the face of a deck board, and into the shelf for additional support.

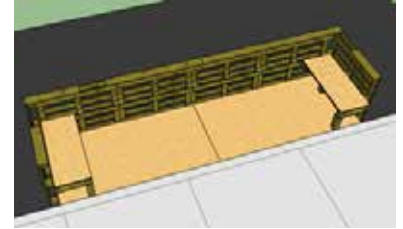

Add 1" by 6" boards on open ends of end cap pallets (both street side and sidewalk side).

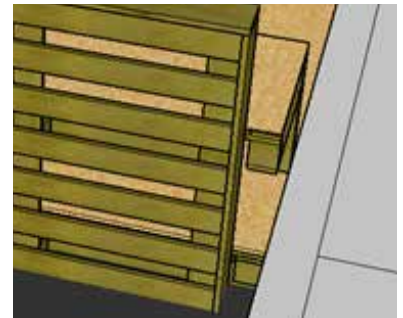
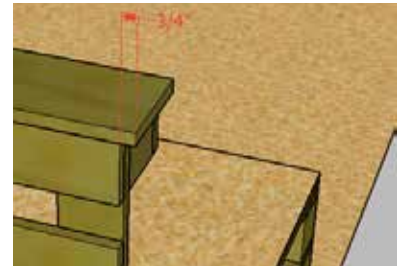

Add wheels stops and flexible bollards. Wheel stops should be at least 2 feet from the end caps on both sides of each parklet. The bollards should be at least 6" from the face of the parklet and 10 feet on center. The outside edge of the bollards should not extend past the inside of the parking lane line.

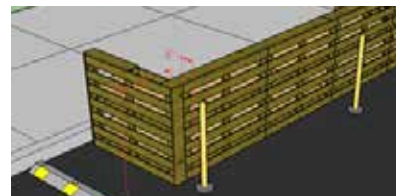

MOBILE PLANTER CONSTRUCTION MATERIALS

Two rigid casters and two swivel casters with side brake. The rigid casters go on one of the short ends and the locking swivel casters on the other. This allows planters to be moved more predictably and easily and makes it easier to lock in position than if all casters swiveled.



Everbilt 2 in. Soft Rubber Swivel Plate Caster with 90 lb. Load Rating and Side Brake
Model# 49509



Everbilt 2 in. Soft Rubber Rigid Caster with 90 lb. Load Rating
Model# 49481

Two Pennington black plastic liners for 36" wide window box (actual dimensions: 32" long, 5.5" wide and 5" tall) - Not considering soil or plants as part of the build



One 11/32 in. x 4 ft. x 8 ft. Rtd Southern Yellow Pine Plywood Sheathing (Model # 166065 Internet #100003677 Store SKU #166065) -Be careful to select sheets with minimal damage to edges and without too many pitch pockets and knots. Be careful not to damage plywood during transportation!



2x 4 x 96 in. Premium Kiln-Dried **Whitewood Stud**

You'll need just over five 8 foot lengths of 2 x 4s per planter Model # 161640 - Be careful in selecting relatively straight studs without significant pitch pockets, knots and other irregularities



Alexandria Molding

WM 105 3/4 in. x 3/4 in. x 96 in. Poplar Wood Primed Finger-Jointed Quarter Round Molding

Model # 0W105-97096C Internet #205958669 Store SKU #805777 - You will need 6 of these. One of the biggest costs in the build!

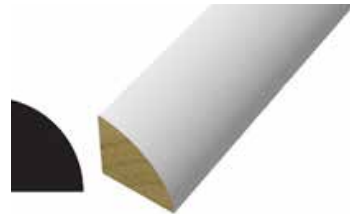

KILZ 2 1 gal. Gray Water-Based Latex Multi-Surface Interior/ Exterior Primer, Sealer and Stain-Blocker TP Model# 22941



Elmer's indoor/outdoor wood glue

Model # E7310 Internet #202819838 Store SKU #814691 (16 oz)- Make sure to use wood glue rated for exterior applications!



#8 x 1-1/4 in. **Star Flat-Head Wood Deck Screws** (1 lb. Pack)

Model # 177931 Internet #202308466 Store SKU #177931 - (needed to attached casters and some wood blocks)



Everbilt #10 x 2-1/2 in. **Star Flat-Head Wood Screws** (1 lb.-Pack)
Model # 116003 Internet #205143008 Store SKU #1000050855 - Used to firmly join butt joint 2 x 4s and blocks to facilitate glue integrity



Porter-Cable

16-Gauge x 1-1/4 in. Glue Collated Finish Nail (1000 per Box) - Model # PFN16125-1 Internet #100138111 Store SKU #549207



DEWALT

1/4 in. x 1/2 in. x 18-Gauge Crown Staples (2500-Pieces)

Model # DNS18050-2 Internet #205647402 Store SKU #1001188144- These are needed to attach artwork to sides of planter



Porter-Cable

16-Gauge x 2-1/2 in. Finish Nail 1000 per Box, - Model # PFN16250-1 Internet #100064480 Store SKU #554689



PLANTER ASSEMBLY

This assumes work will be performed at a well-equipped wood shop with access to pneumatic nail guns, a panel saw, a table saw, a power drill and a miter saw. Ideally, there are also large tables (with a minimum dimension of at least 40") to layout sides of planters while under construction. These planters are designed to accommodate printed artwork (36" x 36" by approximately 1/8" thick) on the wide sides, though one could always paint directly onto the visible plywood surfaces (after they have been primed) if one desired.

Anytime, you are using the 2 ½ inch wood screws, it would be a good idea to drill a pilot hole (using an eight inch wood drill bit) to a depth of at least 1 ½ inches to ensure that the wood does not split. Please make sure to use exterior paint and glue!!!

Step 1: Create Main Side Panels of the Planter

1. Using a panel saw make two cuts to the 4 by 8 foot plywood sheet to create two 36 ¼ by 48 inch panels (the remainder from this is not needed for the planter).

2. Using the panel saw make a cut to each of the 36 ¼ by 48 pieces to create two 36 ¼ inch squares.

3. Cut the two remainder pieces (using panel or table saw) to 30 ¾ inches long.

4. Using a table saw, narrow the two panels to 10 ¾ inches wide

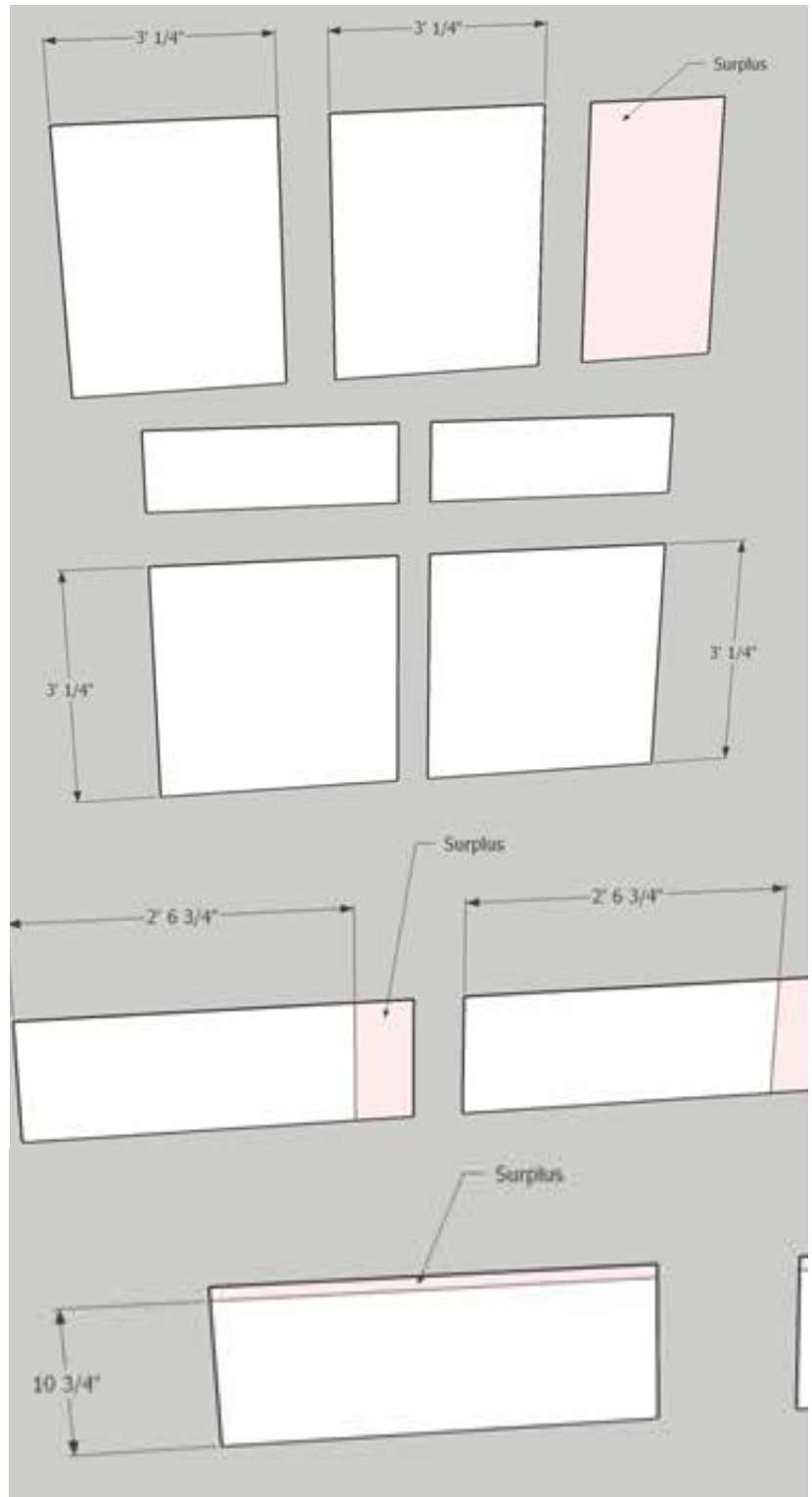

5. Using a miter saw, cut the 2 x 4s to create four 36 ½ inch lengths (sides) and four 39 ½ inch lengths (top and bottom). Draw a pencil line in the middle of each of these studs on the narrow side (this will help to line things up later). Also cut twelve 5" lengths of 2 x 4 and rip four of these in half lengthwise (creating eight pieces which are 5" long by 1.5" by – slightly less than- 1.75"). Mark the middle of each piece on the narrowed side with a pencil to ease placing these in the frame. Cut four 3" lengths of 2 x 4 (these will be cleats for 2 x 4s which will support the planter boxes) and four 2" pieces (these will support the bottom rail of the side panel). Lightly sand all cut ends and smooth other irregularities.

6. Apply glue to ends of 36 ½ " long studs and butt joint to 39 ½ " studs (creating 39 ½ squares) use several 2 ½ inch finish nails to hold studs in place and pre drill a 1/8" hole and drill a 2 ½" wood screw into the center of each joint. Remember: the short side of the stud (the 1.5" wide side) should be facing out!

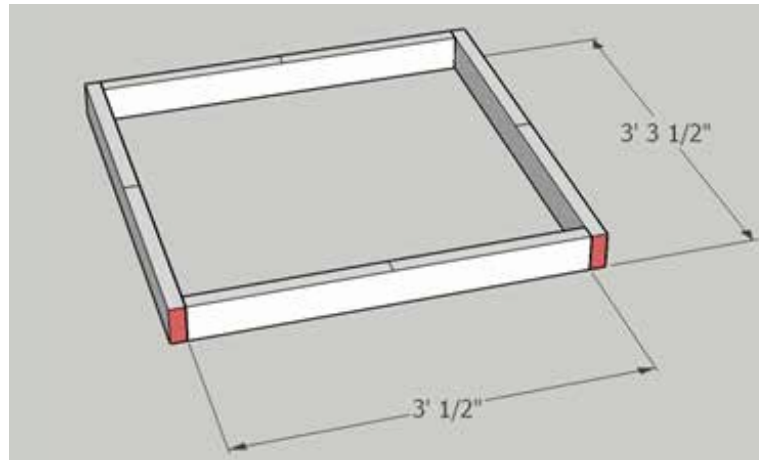

7. Now create the nailing blocks for the plywood panel. Glue the four ripped 5" by 1.75 by 1.5" pieces to the inside middle of each side of the square you just created using the surface of the ripped 2 x 4 as the gluing surface. Secure the block using 2.5" finish nails and a single 2.5" deck screw (coming in from the outside).

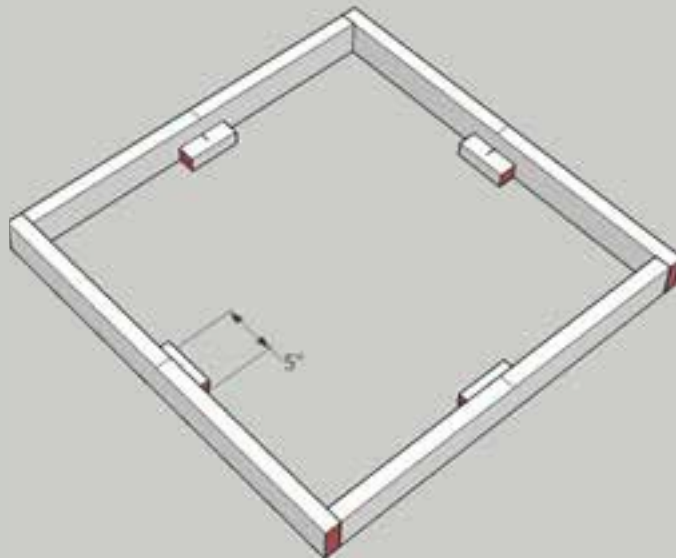

8. Put glue on the nail blocks and place and center the 36 ¼ plywood panel within the square. Use a tape measure to measure across from opposite corners to ensure that the studs are square and nail the panel to the nailing blocks using several 1 ¼ finish nails at each of the nailing blocks.

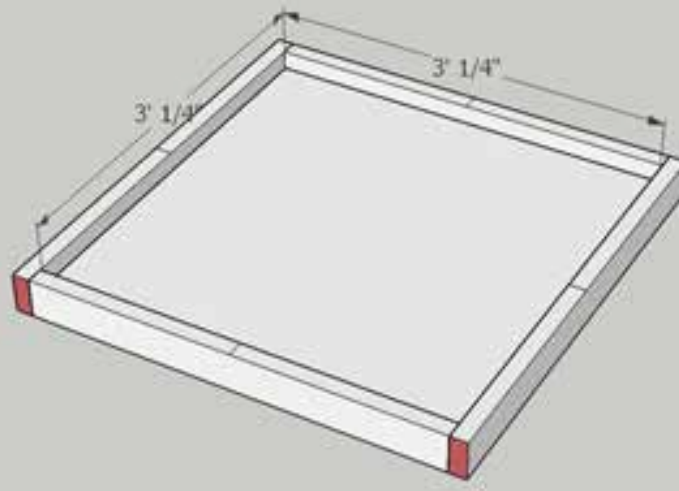

9. Now turn the over the stud framed panel you've created so far (so you are looking at the back) and glue and nail the 4 5" 2 x 4 pieces to each inside corner (so they are parallel with the side framing studs) to serve as corner braces and a nailing surface for the side panel elements. The end of the stud should be glued to top (or bottom) framing stud and the narrow side should be glued to the panel and the long side should be glued and nailed to the side framing studs. Use many 2 1/2 inch finish nails to secure these pieces. Glue (and finish nail) the 3" lengths of 2 x 4 directly above the middle nailing blocks on the sides. Given three points of contact, these will be very strong even before the glue sets. Lift Panel up and use 1 1/4 " finish nails to nail panel to new nail blocks. Place panel back on table with front side facing down and glue and nail the 2" length of 2 by 4 below the corner blocks with the narrow face aligned with the long face of the corner block (this piece will ensure a strong connection with the bottom rails of the side panels). Draw a line 6.5 inches from the top of the top stud and a second line 9 inches from the side.

10. Turn the panel up so it is resting on the bottom stud and then glue the 3" lengths of 2 by 4 directly below the line 6.5 inches from the top and on the line 9" from the side (so the block is within 5.5" and 9" from the side. Secure it in place using 1 1/4 inch finish nails (from the outside face) and add a single 1 1/4 wood screw as well to strong adhere glue.

11. Paint the inside of these panels and let dry overnight. Best to turn upside down so that you can paint the bottom of the bottom stud very well. Don't paint the outer faces of the corner block nor 1.5 inches immediately above the cleat for the planter supports since these will be gluing surfaces for later elements

See on the right side panels primed on the inside and turned upside down and top edge of planter sides in foreground (note planter box cleat supports near bottom of each panel and the absence of paint in future gluing locations)

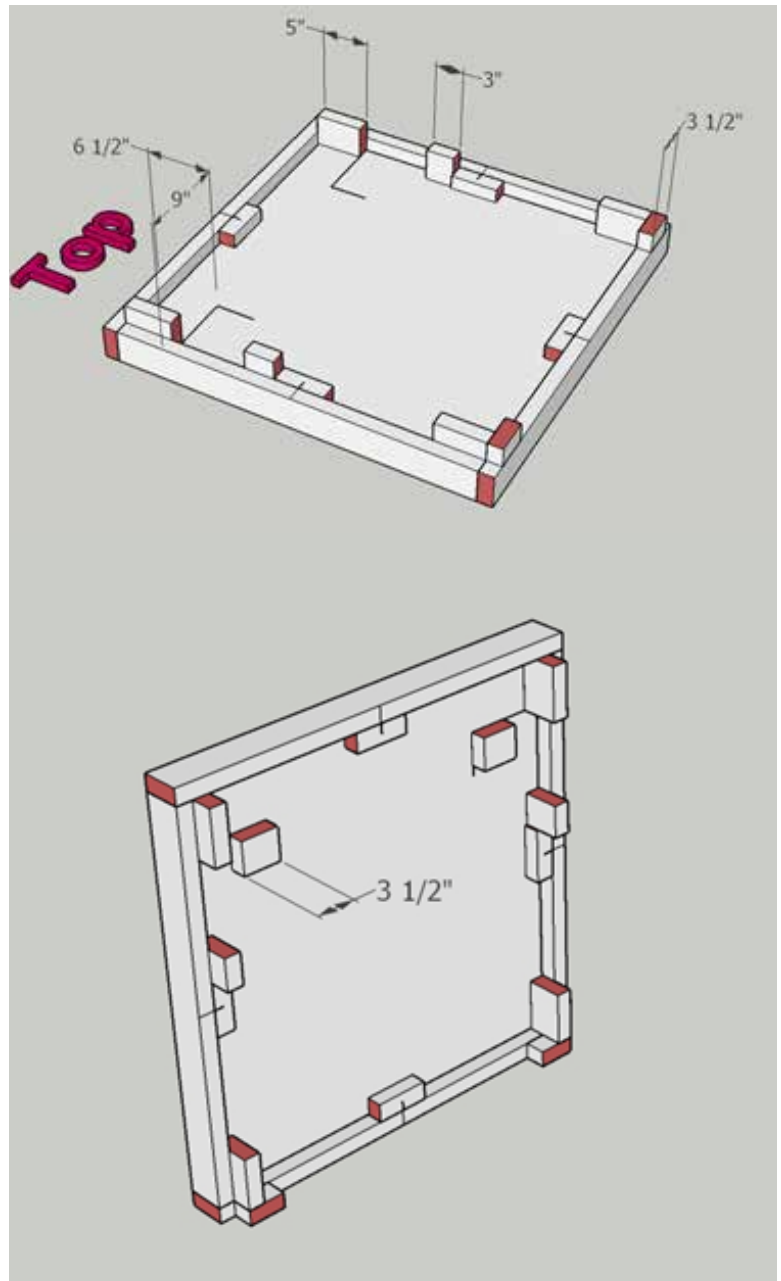

Step 2: Create Side Panel Elements

1. If you have not already done so using a table saw cut the plywood remainder from the $36 \frac{1}{4}$ squares to $10 \frac{3}{4}$ inches by $30 \frac{3}{4}$ inches (see images in Step 1 above).

2. Cut six 11" segments of 2 by 4. These will form the top and bottom pieces of the planter. Lightly sand edges to eliminate splinters.

3. Butt join using glue and $2 \frac{1}{2}$ finish nails short side of two of these to the long side of two others (see figure 1 as well as image below). These will form the top of the side of the planter. Prime the back faces (but not the cut ends)

4. Cut two $13 \frac{3}{4}$ inch segments of 2 by 4 (these will be the planter supports). Prime these except for the cut ends and the last 1.5 inches of the underside.

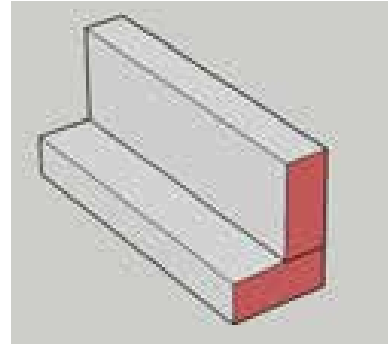

Step 3: Make the Boxes

1. On a level floor, put glue on the top corner nailing blocks and butt ends of top side pieces and nail in place using $2 \frac{1}{2}$ inch finish nails. Add some $2 \frac{1}{2}$ wood screws in strategic places for strong adherence

2. Glue and nail bottom rail

3. Put glue on nailing blocks and center and finish nail side plywood panel to all the nailing blocks using $1 \frac{1}{4}$ finish nails.

4. Place glue on top of planter support cleats nail $13 \frac{3}{4}$ studs to top of each cleat

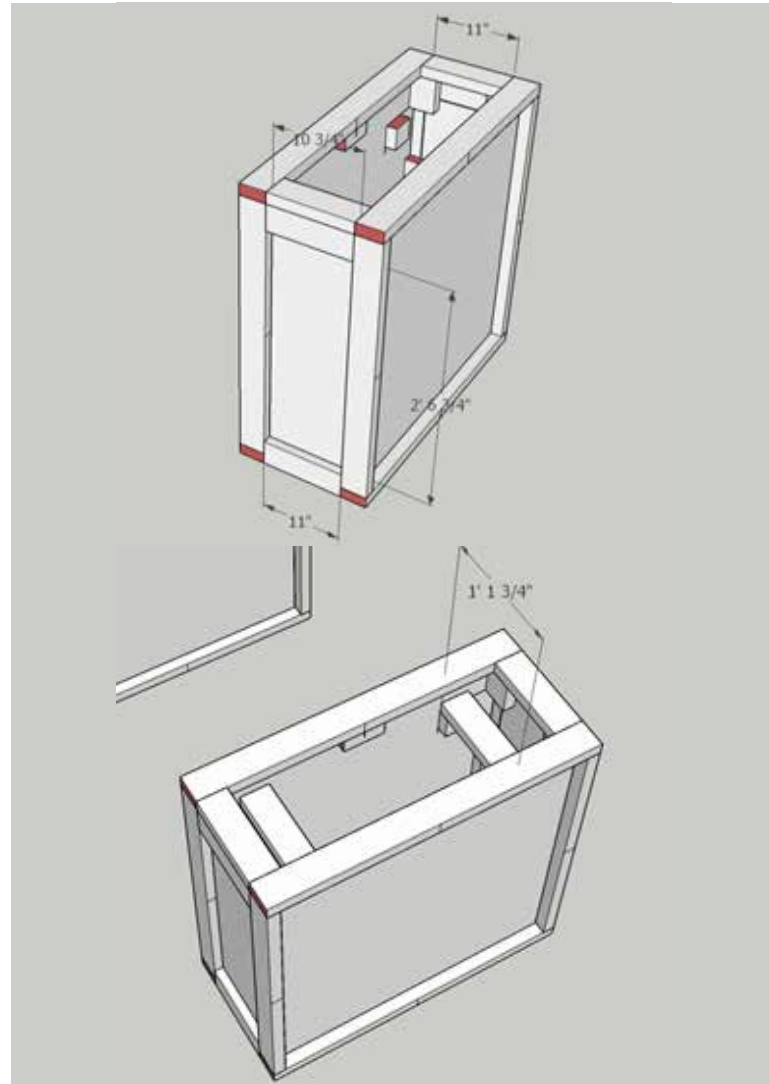

5. Turn planter upside down and thoroughly prime all surfaces, but leave top for later (since it's on the floor).

6. Let dry for a few hours or overnight



Step 4: Attach Casters and Finish Priming Top of Planter

1. Attach casters along center line of bottom studs about 2" in from the ends. Remember to put both swivel casters together on one of the short sides (the swivel casters are both on the left in the image below)

2. Turn planter over to rest on casters, give top a good sanding and prime top of planter.

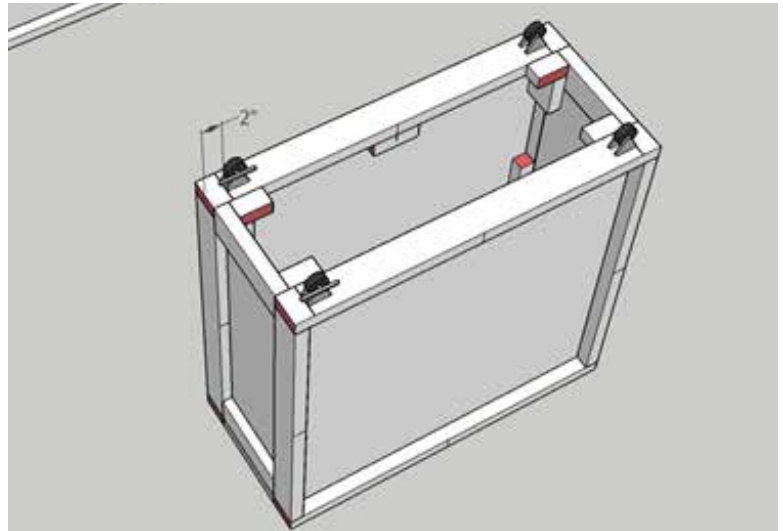

Step 5: Paint Planter, Attach Art, and Apply Quarter Round

Once primer has dried, planter can be painted. Paint exterior of planter and make sure it is dry prior to applying the art. Make sure to use exterior paint! Paint quarter round. Attach artwork to wide sides of planter using 3/8 inch staples. Cut quarter round at a 45 degree angle at each corner (approximate dimensions will be 36.5 inches (square) for wide sides and 31 inches by 11 inches on narrow sides).

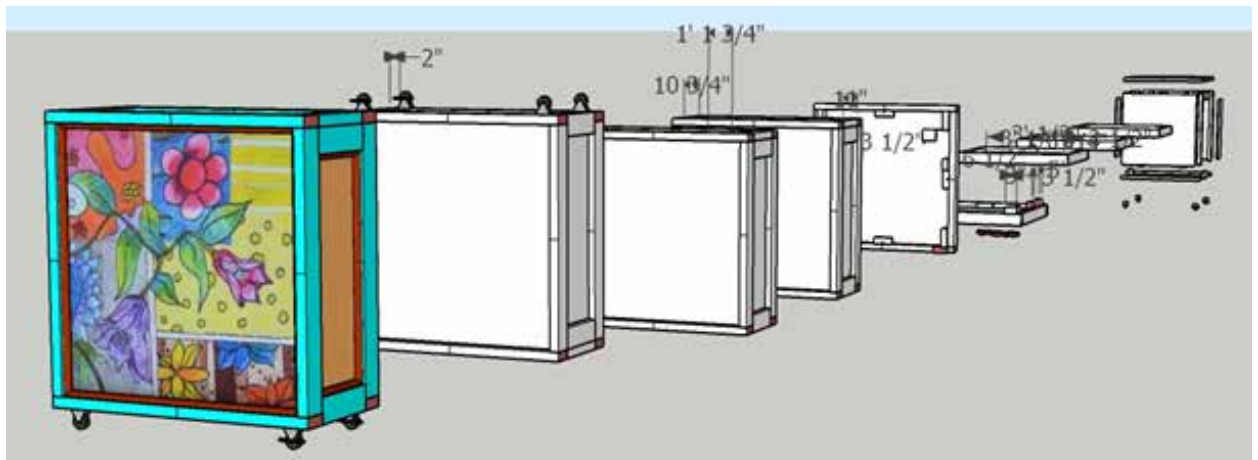

Planter Materials List	Number need for One Planter	Length			Total Length of 2 x 4s needed		
		In Feet	& Inches	Inches	In Feet	& Inches	Inches
2 x 4s							
Full width Elements							
Top and Bottom of Frame	4	3	3 1/4	39 1/4	13	1	157
Sides of Frame	4	3	1/4	36 1/4	12	1	145
Top and Bottom Rails for Side of Planter	6	0	11	11	5	6	66
Support for Planter Boxes	2	1	13/4	13 3/4	2	3 1/2	27 1/2
Corner Nailing Blocks	8	0	5	5	3	4	40
Cleats for Planter Box Supports	4	0	3 1/2	3 1/2	1	2	14
Supports for Side Panels in Middle	4	0	3	3	1	0	12
Blocking for Bottom Side Rails	4	0	2	2	0	8	8
2 x 4 ripped in half (1.5 by 1.75 inches)							
Middle Nailing Blocks	8	0	5	5	1	8	20
Total Length of 2 x 4s per Planter							
					40	9 1/2	489 1/2

This page left intentionally blank.



APPENDIX E: HISTORY OF GREATER CHATHAM

Brief Historic timeline of Chatham, prepared by the Greater Chatham Initiative.

Greater Chatham encompasses four neighborhoods in the South Side of Chicago: Auburn Gresham, Avalon Park, Chatham and Greater Grand Crossing. These four neighborhoods have similar histories and today are served by the Greater Chatham Initiative as one focus area.



History of Greater

<p>1852</p> <p>Land for the crossing point at Illinois Central was stolen from the Northern Indians</p>	<p>1860</p> <p>First buildings, corn cribs, constructed in Chatham by the Illinois Central Railway</p>	<p>1930</p> <p>Area is considered residentially and commercially mature</p>	<p>1918</p> <p>Bungalow building boom</p> 	<p>1949</p> <p>Resident Mahalia Jackson sold over 1 million copies of "Move on Up a Little Higher"</p> 	<p>Park Manor neighborhood in 1949 erupted into a riot when a mob of whites used sticks, bricks and bottles to drive a black football team out of a local park</p>	<p>1952</p> <p>Chatham- Avalon Park Community Council (CAPCC) announced first public meetings</p>	<p>1954</p> <p>Realtor Joseph Bridges was the first black to open a business on 79th Street in Chatham in the fall</p>
--	---	--	---	---	--	--	--

INDUSTRIAL AGE (1836-1949)

AFRICAN-AMERICANS

<p>1836</p> <p>The swamp land that became Chatham was bought by John L. Wilson</p>	<p>1876</p> <p>First factory put in place, the Cornell Watch Factory</p>	<p>1938</p> <p>Restrictive covenants are outlawed, thanks in part to resident Carl Hansberry</p>	<p>1955</p> <p>Dixon Elementary accepts its first black student</p> <p>Chatham-Avalon Park Community Council includes blacks</p>
<p>1853</p> <p>First train wreck in Chicago that gave Greater Grand Crossing its name, caused 18 deaths and 40 injuries</p>	<p>1926</p> <p>First electric train put into service</p>	<p>1950</p> <p>Gwendolyn Brooks receives the Pulitzer Prize for her poem, Annie Allen</p> 	<p>1953</p> <p>Rev. William J. Faulkner becomes the first pastor of the Congregational Church of Park Manor and the first black pastor in the neighborhood</p>

Chatham

1961

United American Progress Association founded, dedicated to improvement of the economic condition of black Americans

1959

Chatham resident Lorraine **Hansberry's** A Raisin in the Sun opens to the public on March 11, 1959



1964

Independence Bank was founded by George Johnson



1971

Chatham Business Association founded to combat extortion from gangs, enhance business community and create kinship

1973

Whitney M. Young, Jr. Library was created, named after the former executive director of the Urban League

1977

Ernie Banks is inducted into the Baseball Hall of Fame

2013

W. Kamau Bell is named the American Civil Liberties Union celebrity ambassador on racial justice

Ernie Banks earns the Presidential Medal of Freedom for his contribution to sports

2017

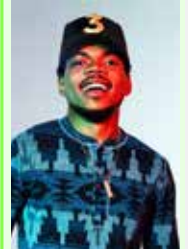

Chance the Rapper earns three Grammy awards for Best New Artist, Best Rap Performance and Best Rap Album

(1950-1960)

CHATHAM GOLDEN YEARS(1961-)

1960

Chatham is 63.7% black

1965

Chatham Southeast Citizen Newspaper first published on April 15 1965, by Gus Savage, propagated the concept of black economic empowerment

1968

South Central Community Service Inc., was founded after the community raised \$79,000 to have a neighborhood mental health clinic

The Nat "King Cole was Park was dedicated on a Sunday, July 14, 1968

Fair Housing Act is passed

1972

Herbert Nipson becomes Executive Director of Ebony Magazine



1987

Eugene Sawyer becomes Mayor of Chicago

2009

Roland Burris is sworn in to the Senate to replace Barack Obama

2016

The South Side: A Portrait of Chicago and American Segregation is published by Chatham native and journalist Natalie Y. Moore



APPENDIX F: PUBLIC WAY USE

If a business has a sign, canopy, awning, bench, or anything that extends over, under or is on the public way, it requires a Public Way Use Permit (Grants of Privilege) issued by the Department of Business Affairs and Consumer Protection (BACP) - Public Way Use (PWU) Unit. The process to obtain the permit requires City Council approval.

In addition to a Public Way Use permit, all business identifiers such as signs, awnings, canopies and banners are required to have a Sign Construction Permit from the

Department of Buildings. Only a licensed sign contractor may apply to obtain a Sign Construction Permit.

A business may apply for both permits at the same time at BACP. Figure 6 below is reproduced from the City of Chicago Public Way Use Permit application for reference.

For temporary use of the public way due to construction, applicants must obtain a Construction Canopy Permit from the Chicago Department of Transportation.

Note that no fee shall be charged for a public way use that is on or above the public way for residential buildings constructed on or before 1922 (Section 17-17-02146 of the Municipal Code of

Chicago) and for Landmark Designated Buildings, any part of the building which is on or over the public way, including a clock or light fixture in case these were part of the original landmark designation.

CITY OF CHICAGO PUBLIC WAY USE PERMIT APPLICATION



Figure 6: Annual Fees for Public Way Use Permits in 2018 (subject to change)

BACP | SBC-PWU GRANT OF PRIVILEGE APPLICATION PACKAGE

PUBLIC WAY USE	ANNUAL FLAT FEES
Awning	\$50 for the first 25 feet + \$1 each additional foot
Canopy	\$50 for the first 25 feet + \$1 each additional foot
Balcony	\$75 each
Banner	\$75 each
Barber Pole	\$10 each
Bay Window	\$75 each
Bicycle Rack	\$0 / \$50 application fee
Bollard	\$75 each
Cable	\$50 for 1 st 25 feet + \$1 each additional linear foot
Conduit (fiber or not)	\$6 per linear foot
Clock	\$400 each
Door Swing	\$75 each
Fire Escape	\$400 each
Flag Pole	\$75 each
Light Fixture	\$75 for the first + \$5 each additional light
Light Pole	\$75 each
Manhole	\$400 each
Marquee	\$50 for the first 25 feet + \$1 each additional foot
Park Bench	\$75 each
Security Camera	\$0 / \$50 application fee
Sign	\$100 each (if less than 25 square feet)
	\$300 each (if 25 square feet and up)
Smoking Management Receptacle	\$75 each (permanent)
	\$0 / \$50 application fee (portable)
Trash Container	\$75 each
Windscreen	\$400 each
Landscaping	\$0 / \$50 application fee
Planter	\$0 / \$50 application fee
Trees	\$0 / \$50 application fee
Tree Grate	\$0 / \$50 application fee
Combination of Sign (< 25 ft.), Awning, Canopy, Light	\$175 maximum

The fees for all other structures occupying the public way are determined by a formula based on square feet, real estate value, and level (on, over, under the public way), with a minimum charge of \$400 per item per year.

Notwithstanding the above, the total fee for a public way use for any combination of signs less than 25 square feet, canopies, awnings, or light fixtures, at the same location, shall not exceed \$175.00 for all such public way uses.

Exemption: No fee shall be charged for a public way use that is on or above the public way in the following cases:

In the case of a residential building, as that term is defined in Section 17-17-02146, constructed in or before 1922 (with proof provided with this Application), a public way use that is part of the original construction and is a permanent structure of the building; provided that in the case of a mixed used building, any public way use that solely is for the use or benefit of any commercial or business activity in the building shall pay the fee(s) required for the public way use. In the case of a landmark building, any part of the building which is on or over the public way, including a clock or light fixture, if the clock or light fixture is part of the landmark designation. For purposes of this Exemption, a landmark building shall also include any building in a landmark district, other than a non-contributing building. If, in the case of any building specified in this Exemption, the public way use for which the Public Way Use Permit is sought is below grade level or is under the public way or under any other public place, the appropriate fee(s) shall be charged.



1 Two Lights in the public way (\$75 + \$5)

2 Sign over entry: 12' X 1' = 12 Sq. Ft.

3 Sign on door: 2' X 1' = 2 Sq. Ft.

Total sign area = 14 Sq. Ft.

Annual Public Way Fee = \$80

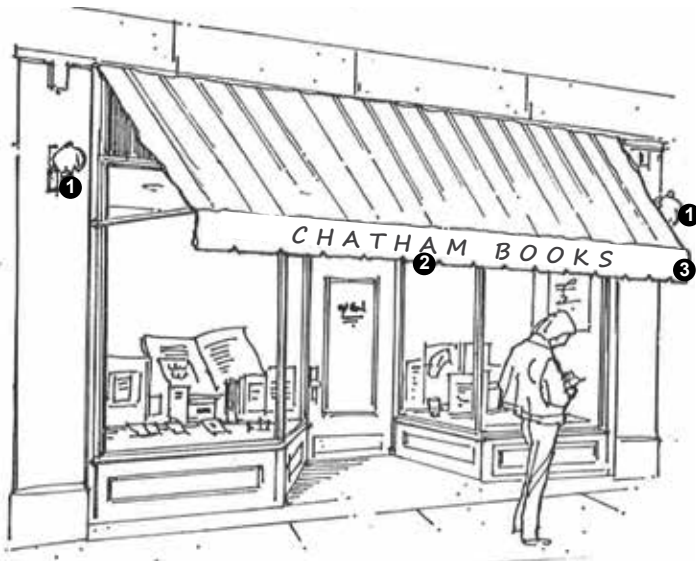

1 Two Lights (\$75 + \$5)

2 Sing on Awning sign (\$100)

3 Awning (\$50)



1 One projecting sign
Less than 100 Sq. Ft. (\$100)

2 Two Lights (\$75 + \$5)
Blade sign: 2' X 3' = 6 ft.

3 Window signs: 2' X 4' = 8 Sq. Ft.

4 Door sign 2' X 2' = 4 Sq. Ft.

Total sign area: 26 Sq. Ft.

Annual Public Way Fee = \$175

Three diagrams showing examples of retail signage and estimated permitting costs (as of 2018)



DPD

CHICAGO DEPARTMENT OF
PLANNING & DEVELOPMENT

DIVISION OF PLANNING, HISTORIC PRESERVATION AND SUSTAINABILITY
121 N. LASALLE STREET, ROOM 1000
CHICAGO, IL 60602
2018