

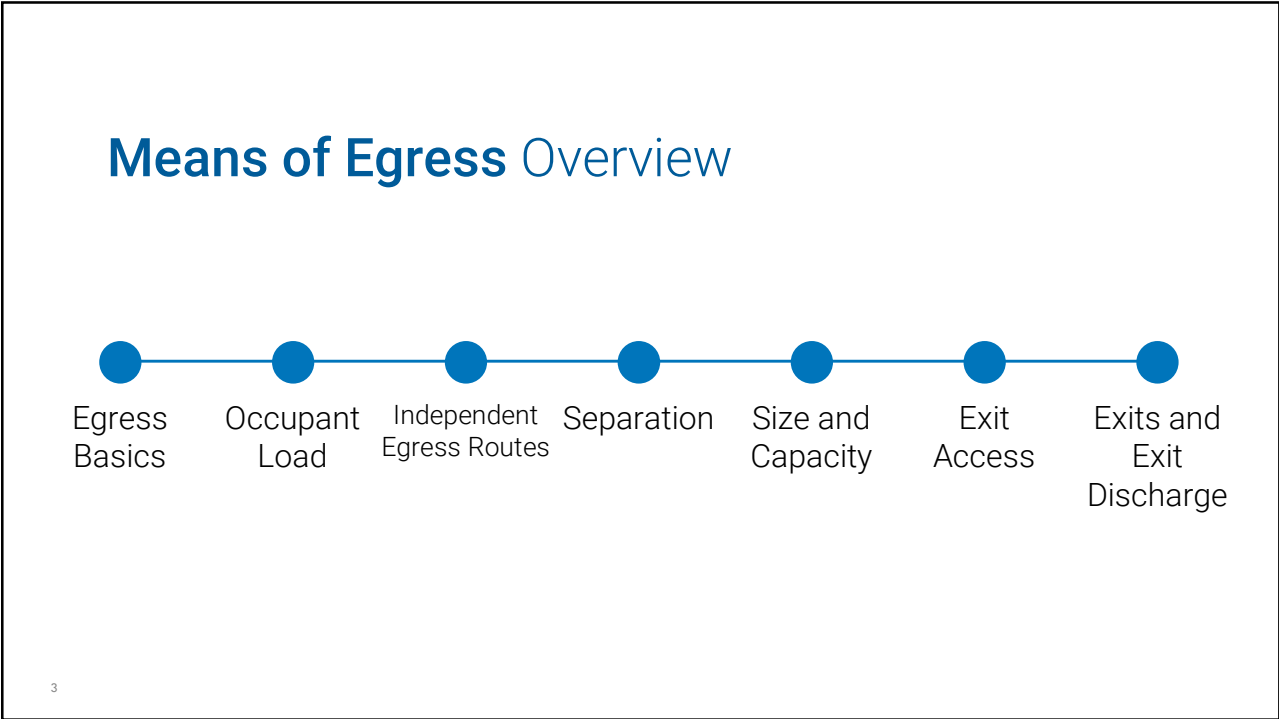



2



3



# Egress Basics

Definition

Components

4

4



## Means of Egress

A continuous and unobstructed path of vertical and horizontal egress travel from any *occupiable space* in a *building* or *structure* to a *public way*.

5

5

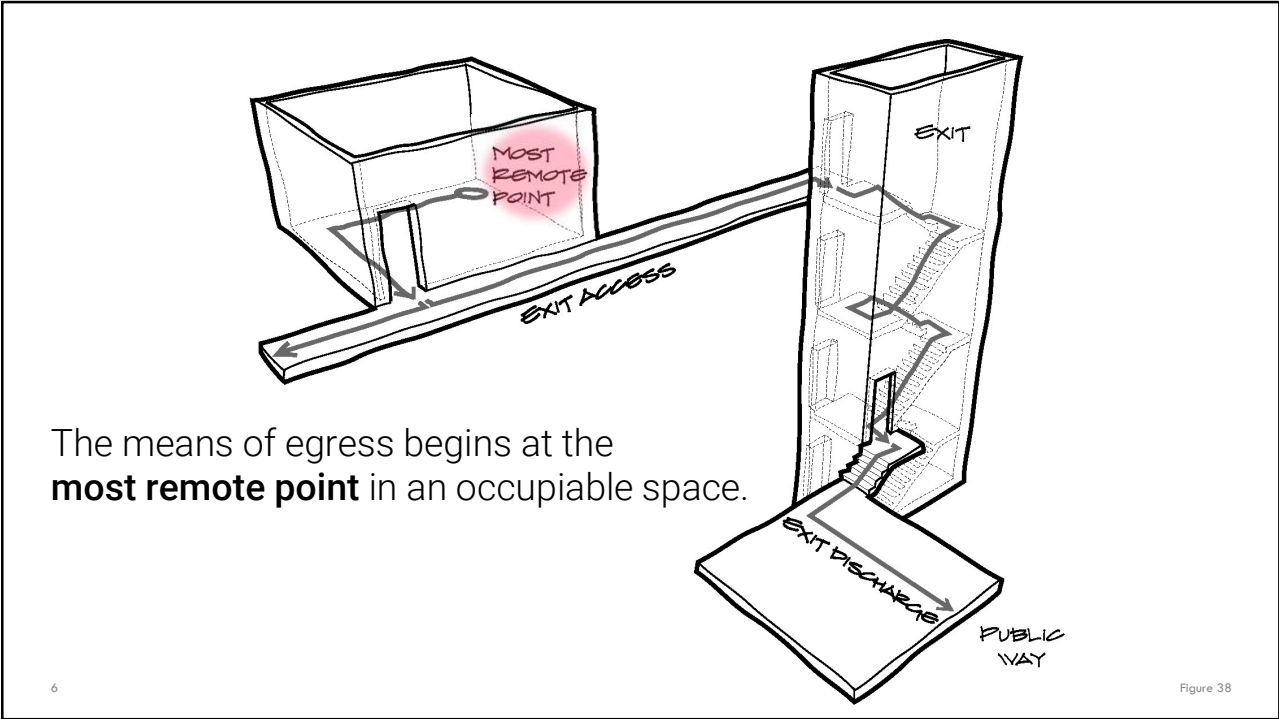

6

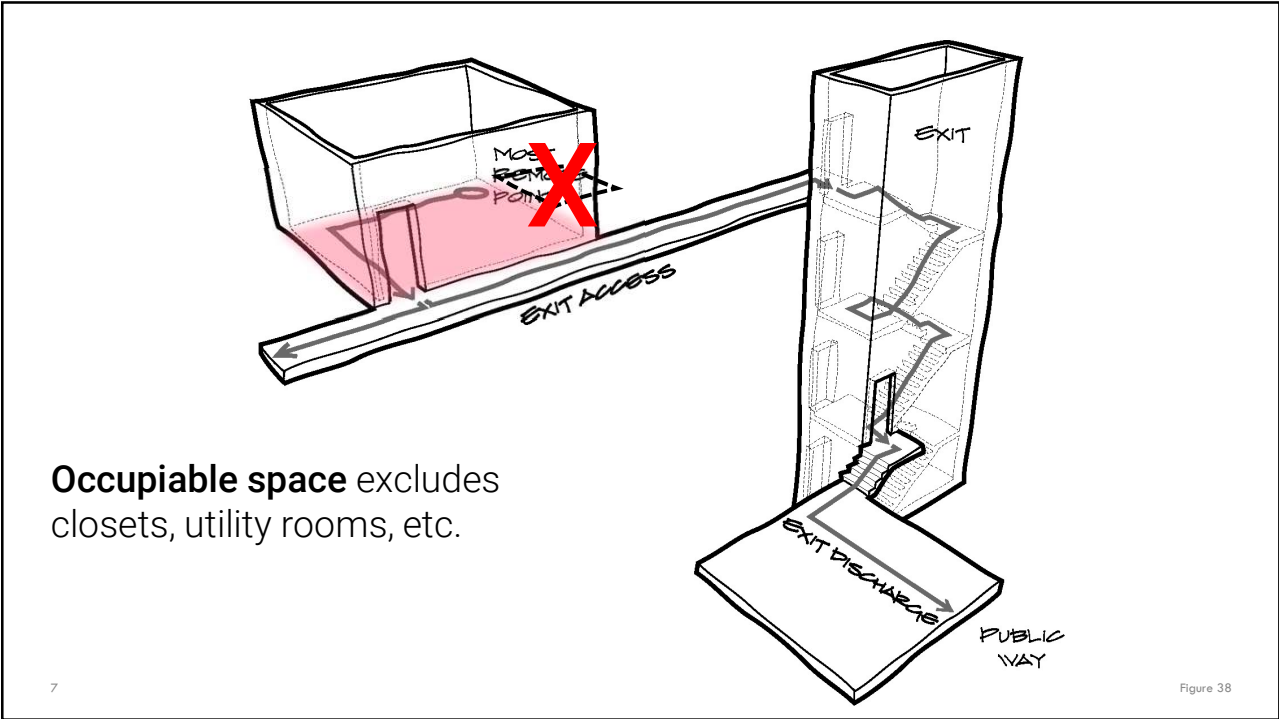

7

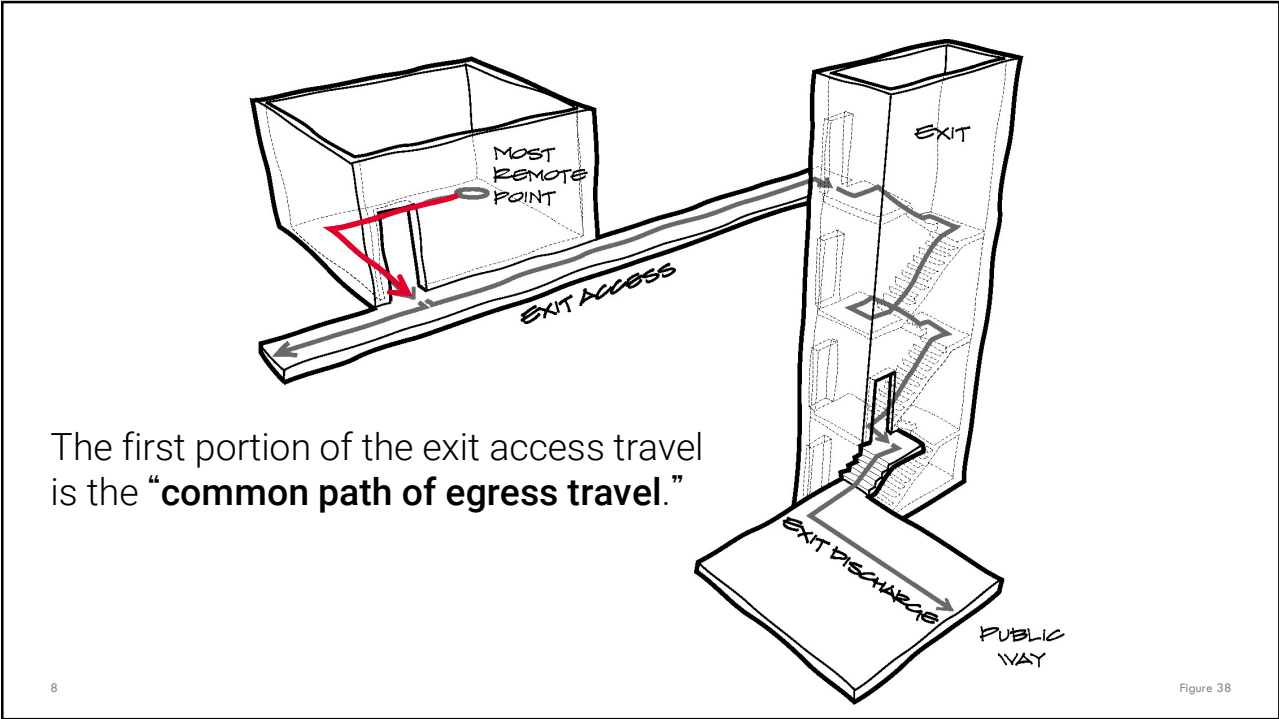

8

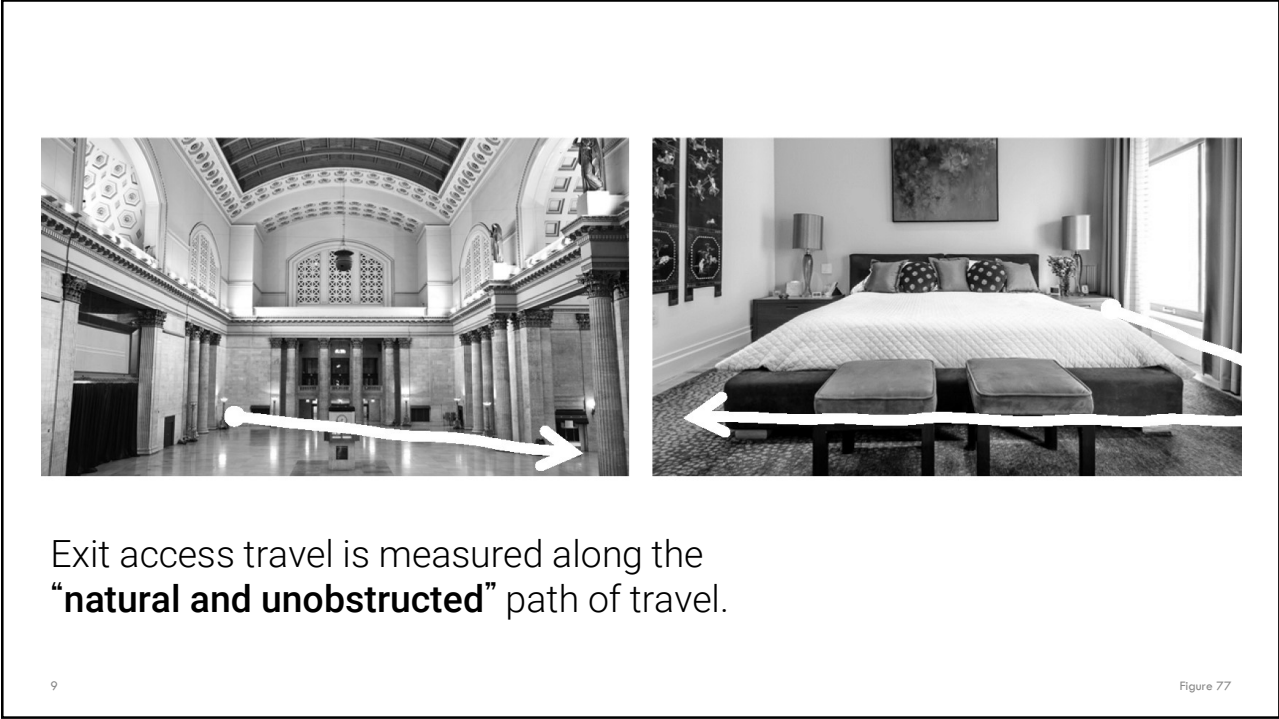

9



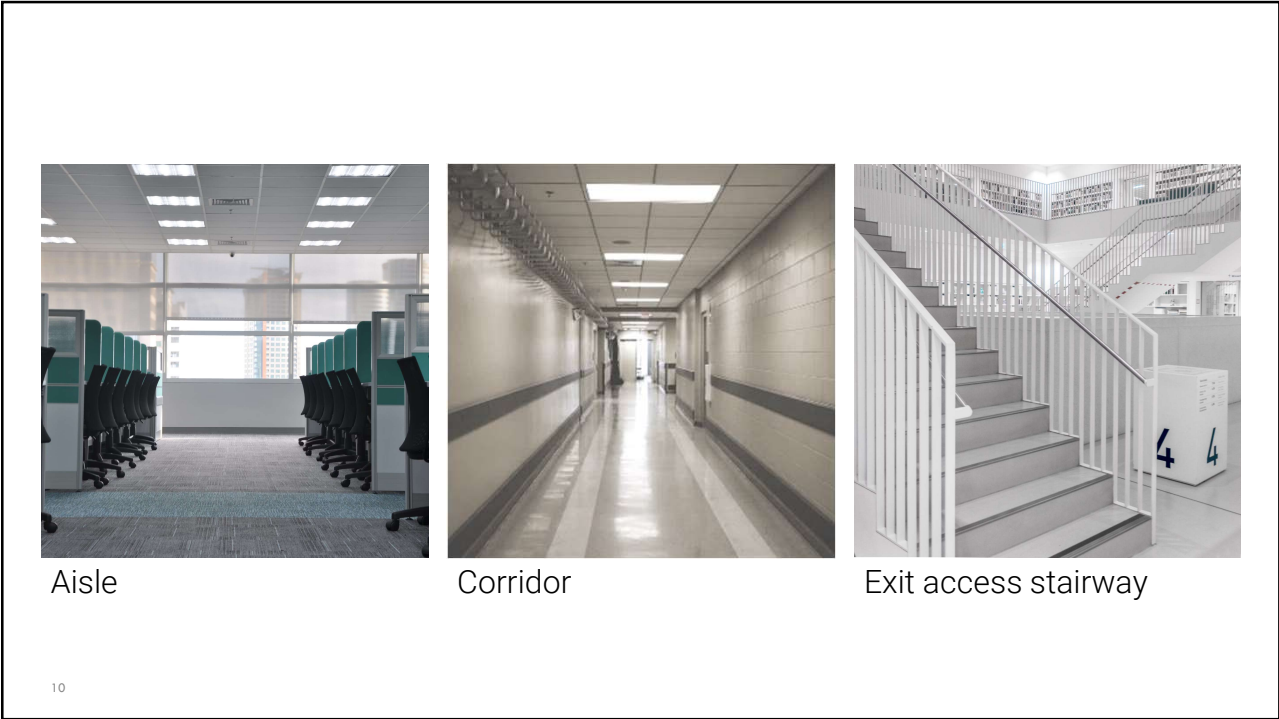

10

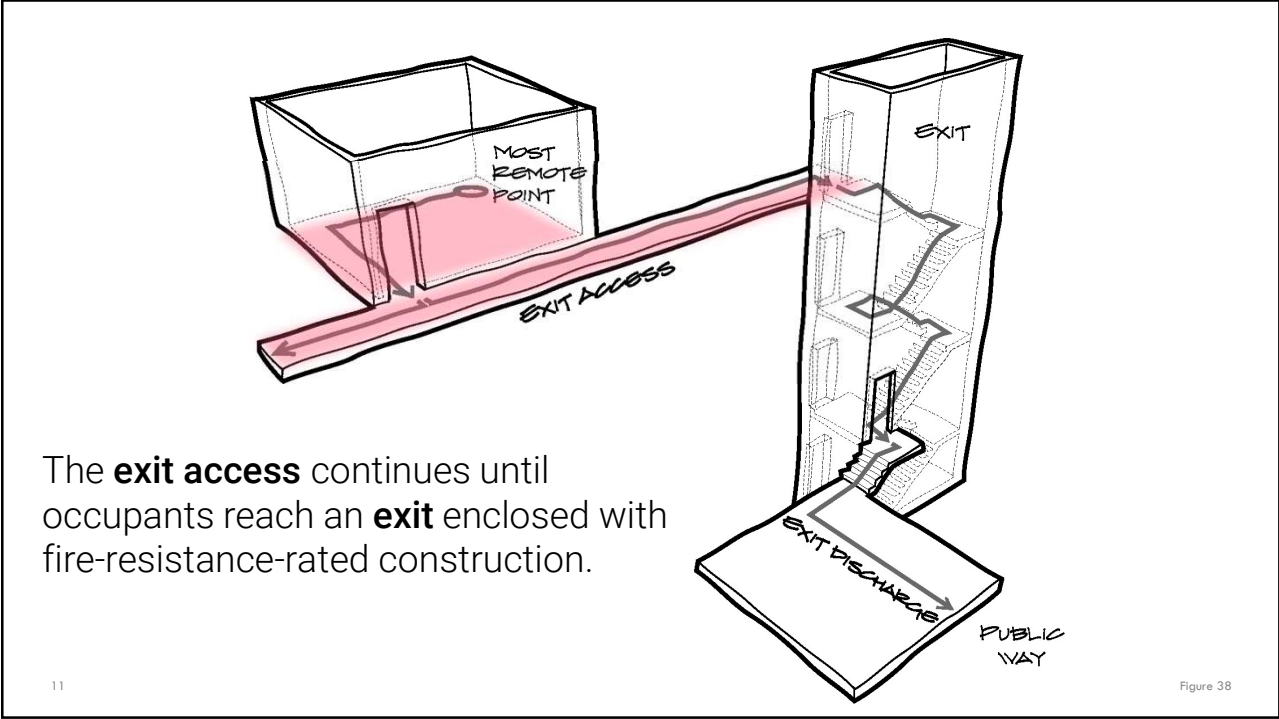

11

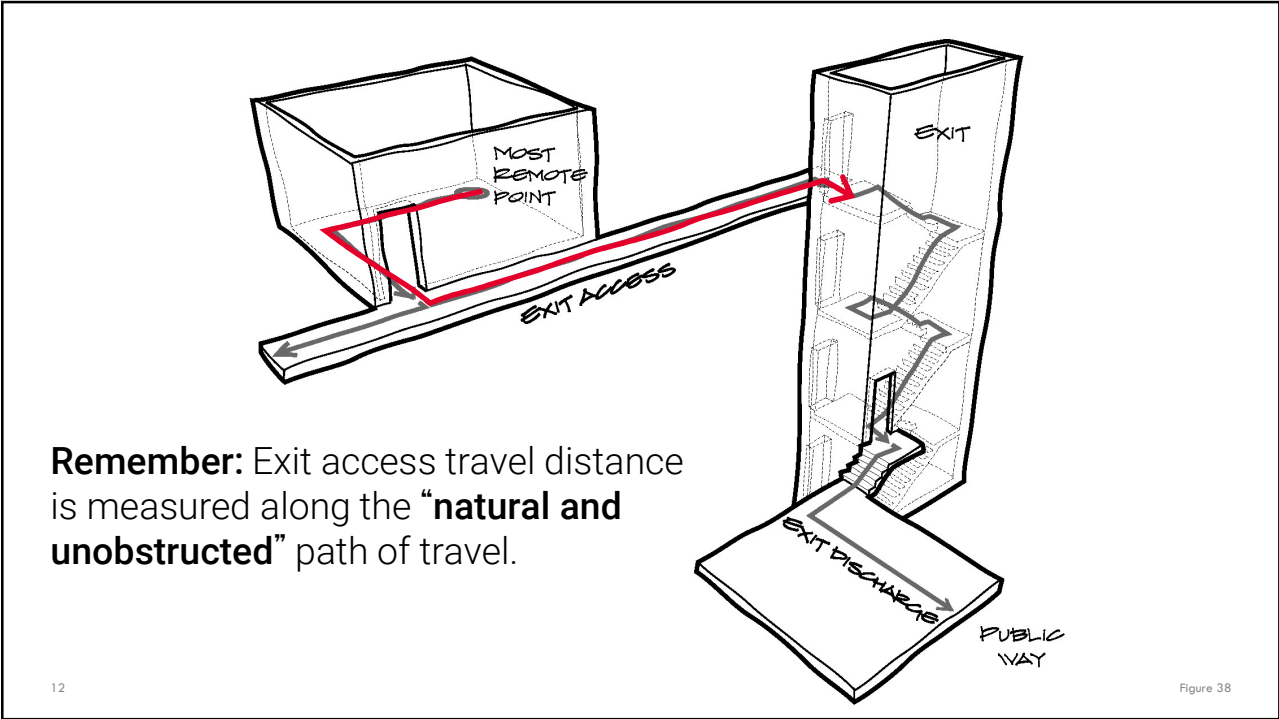

12

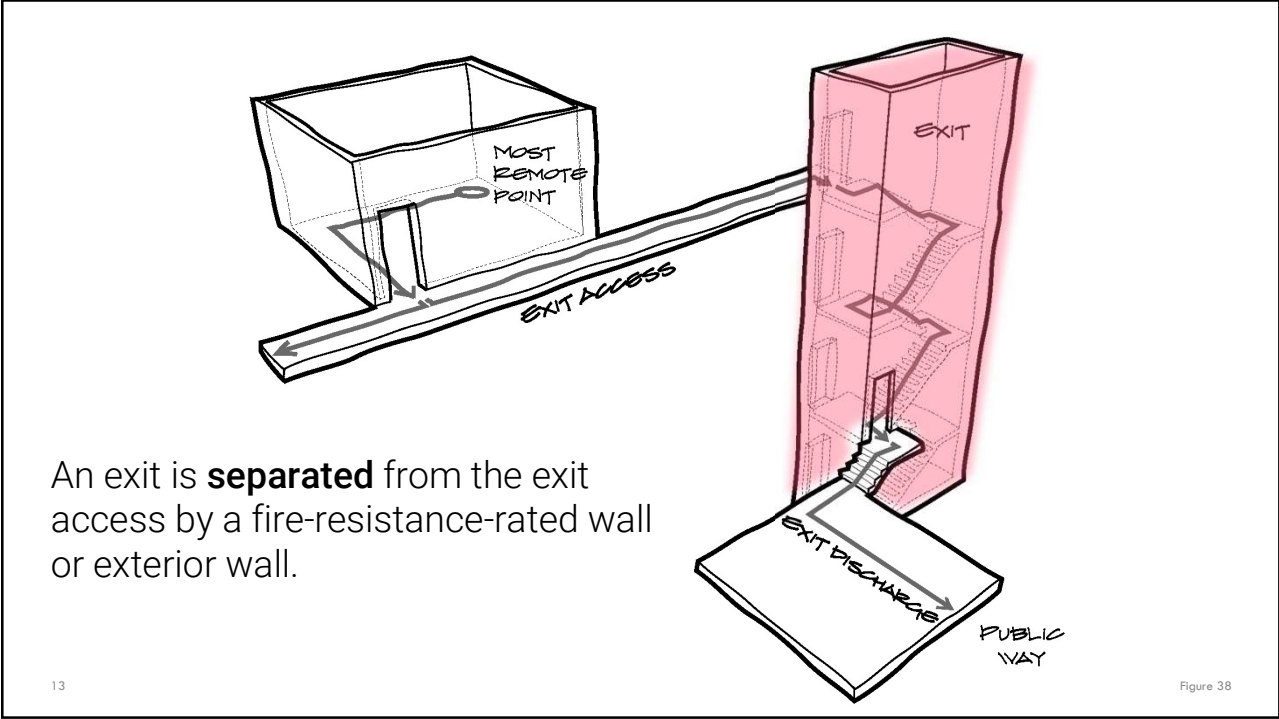

13



14

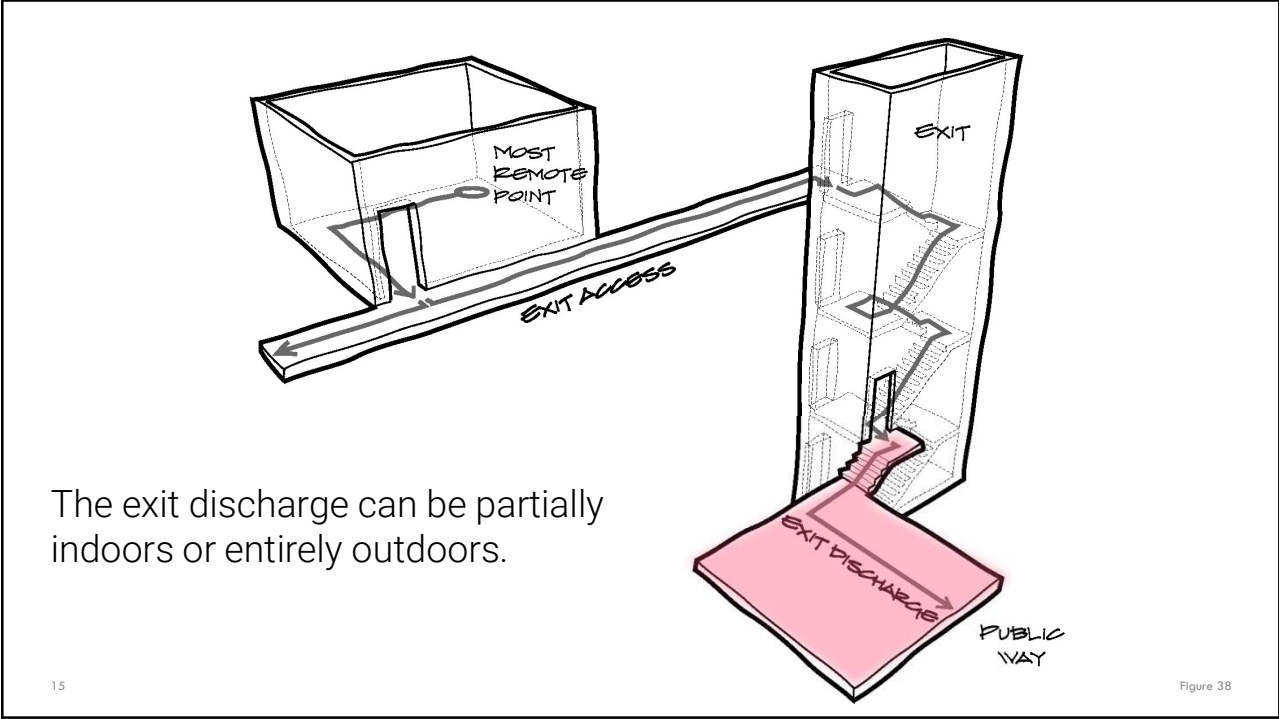

15

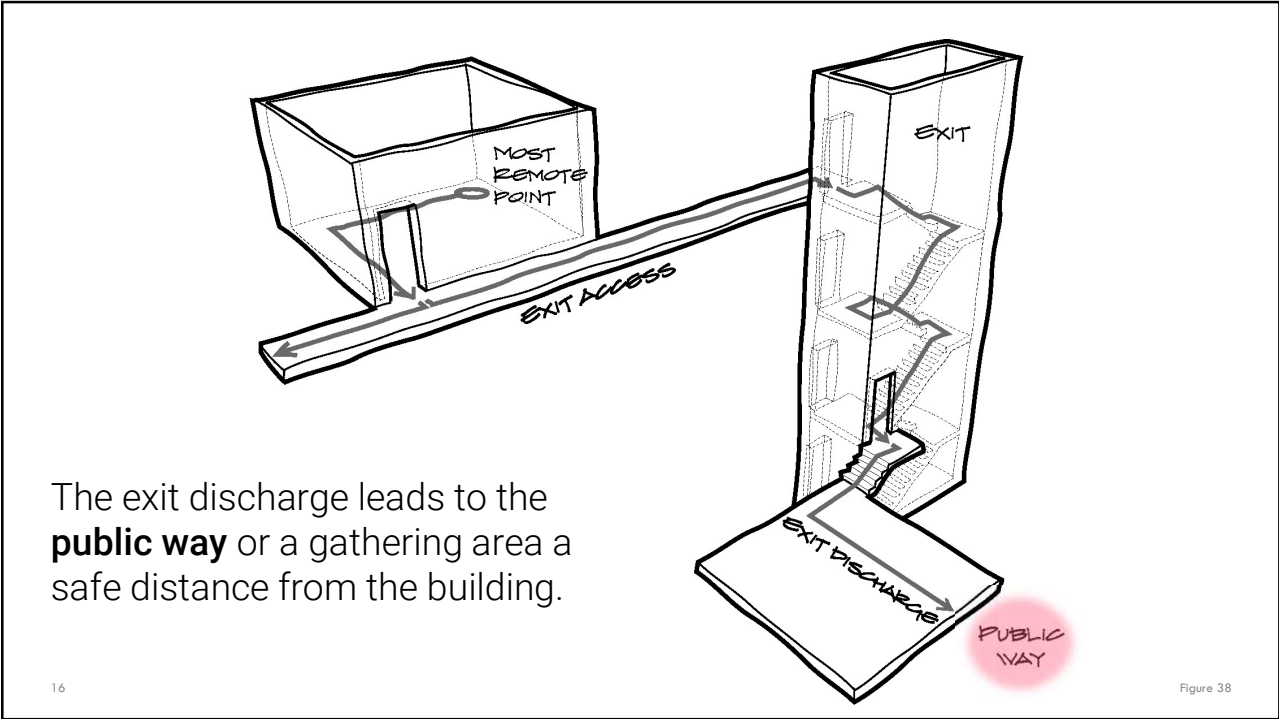

16

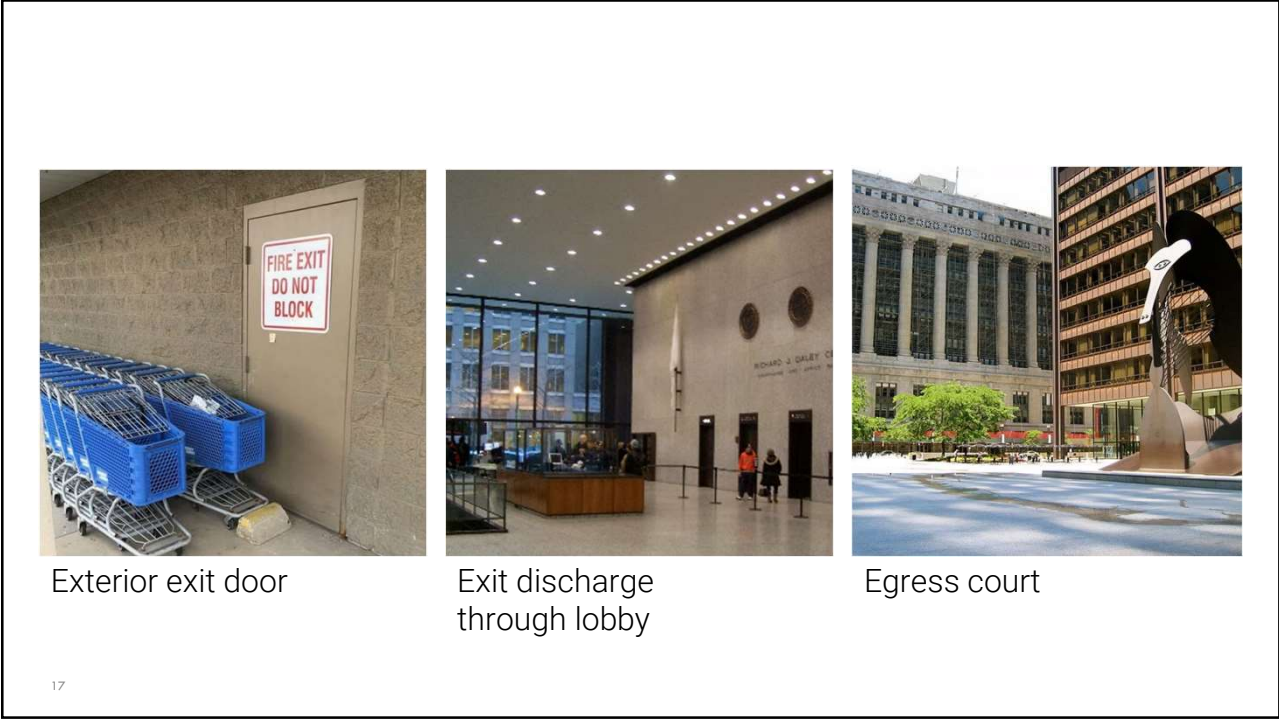

17

At the **Daley Center**, the exit stairs discharge into the ground-level lobby. After exiting the building, occupants must cross the plaza (egress court) to reach a public way.

Both the **lobby** and **plaza** are exit discharge components.

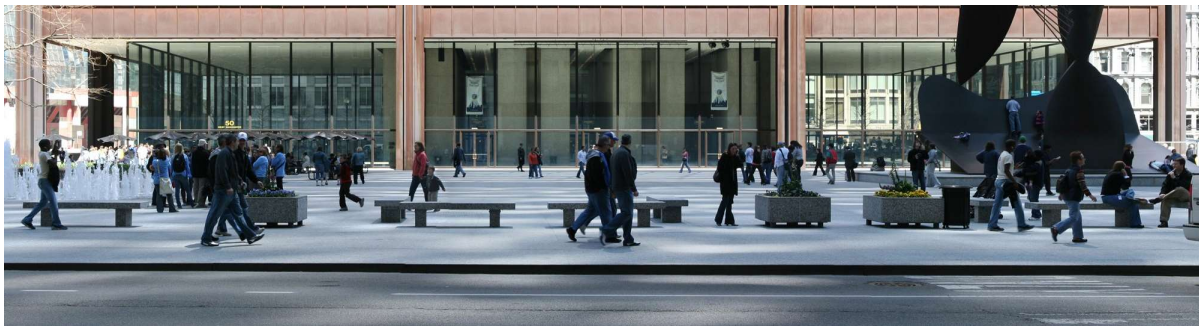

18

slido



What egress requirement is most challenging to understand?

① Start presenting to display the poll results on this slide.

19



slido



## Audience Q&A Session

① Start presenting to display the audience questions on this slide.

20



# Design Occupant Load

- Purpose
- Calculation
- Net vs. gross area
- Example
- Special conditions

21

21

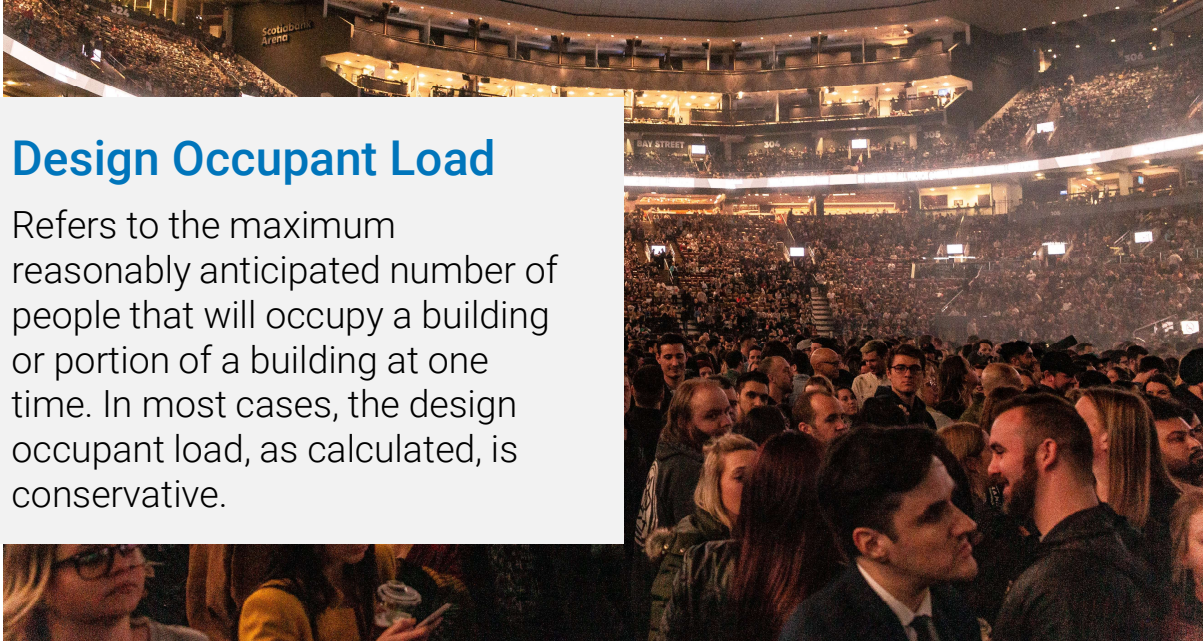

**Design Occupant Load**

Refers to the maximum reasonably anticipated number of people that will occupy a building or portion of a building at one time. In most cases, the design occupant load, as calculated, is conservative.

22

22

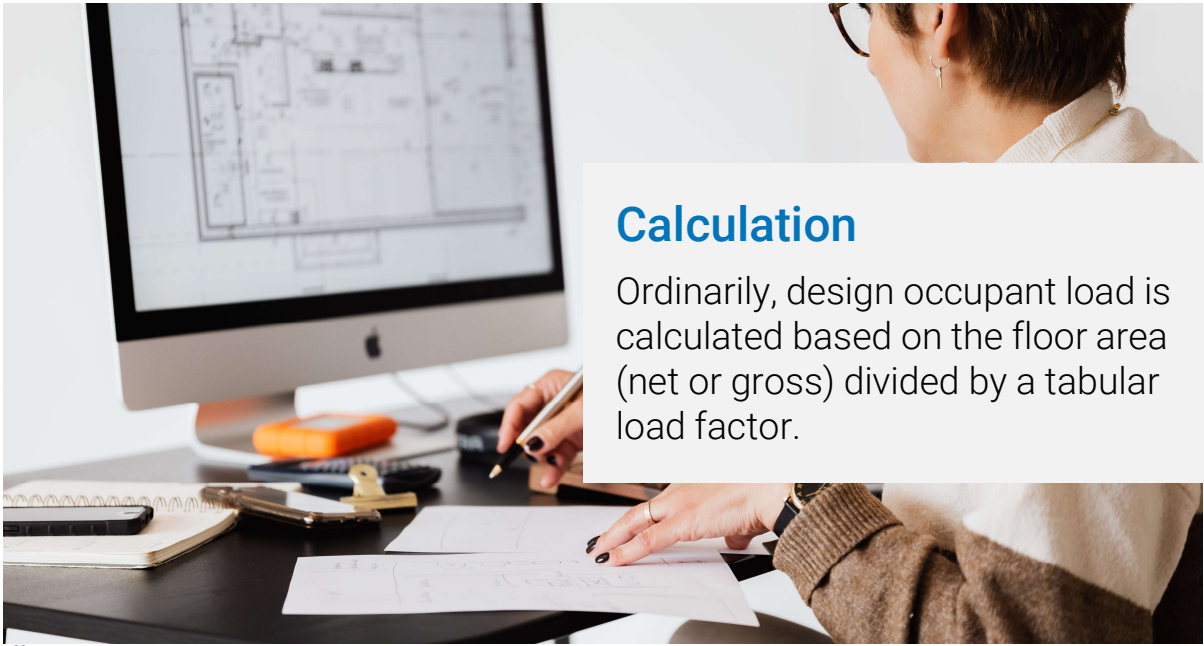

**Calculation**

Ordinarily, design occupant load is calculated based on the floor area (net or gross) divided by a tabular load factor.

23

23



24

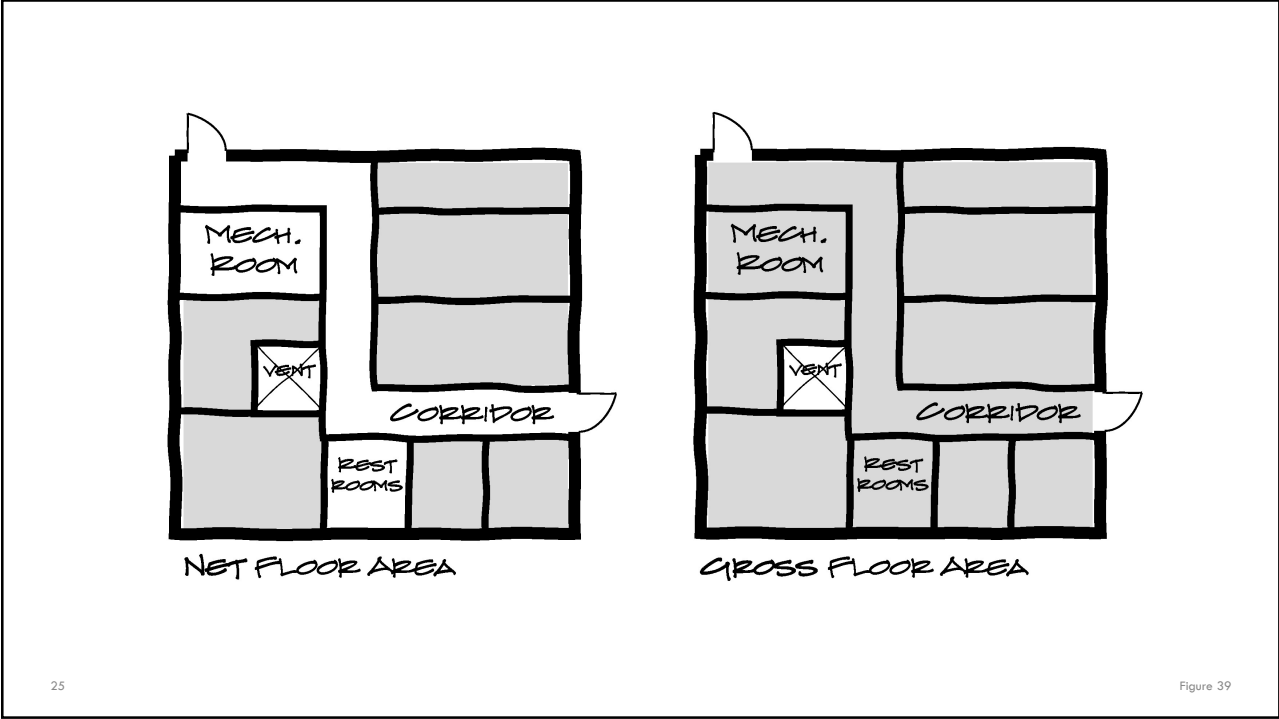

25

Figure 39

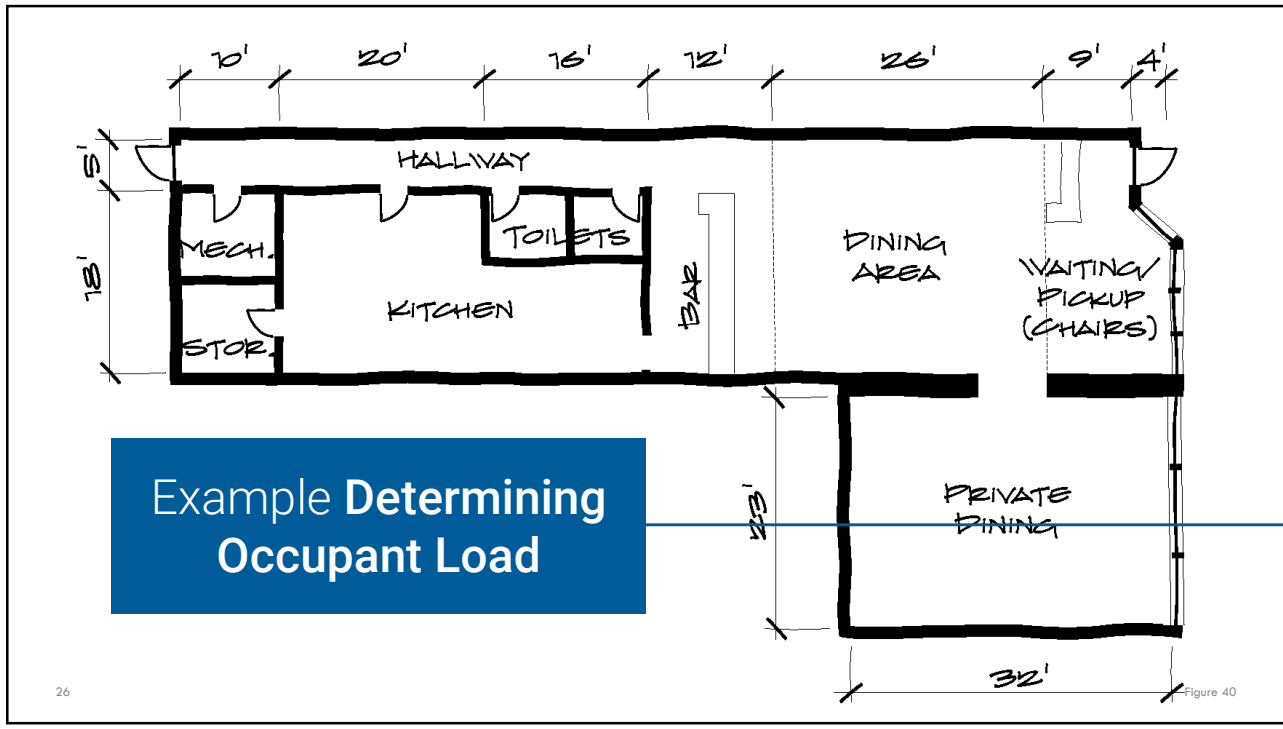

26

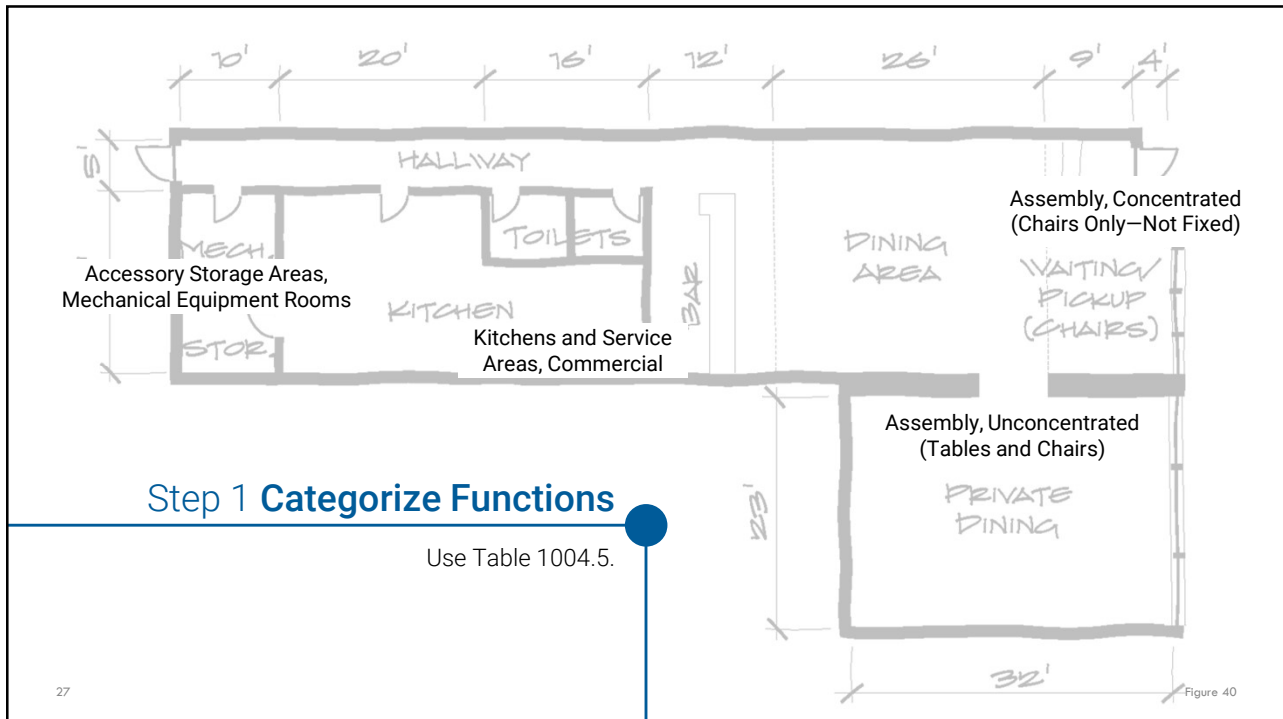

27



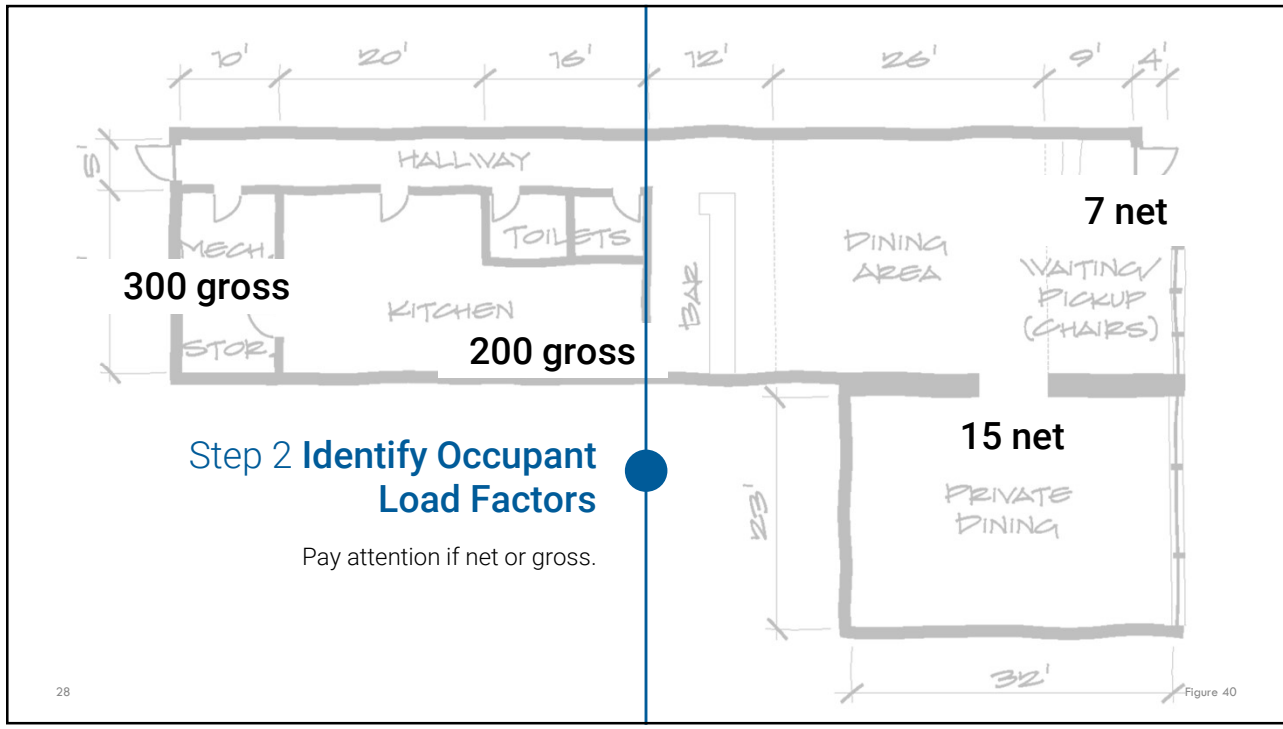

28

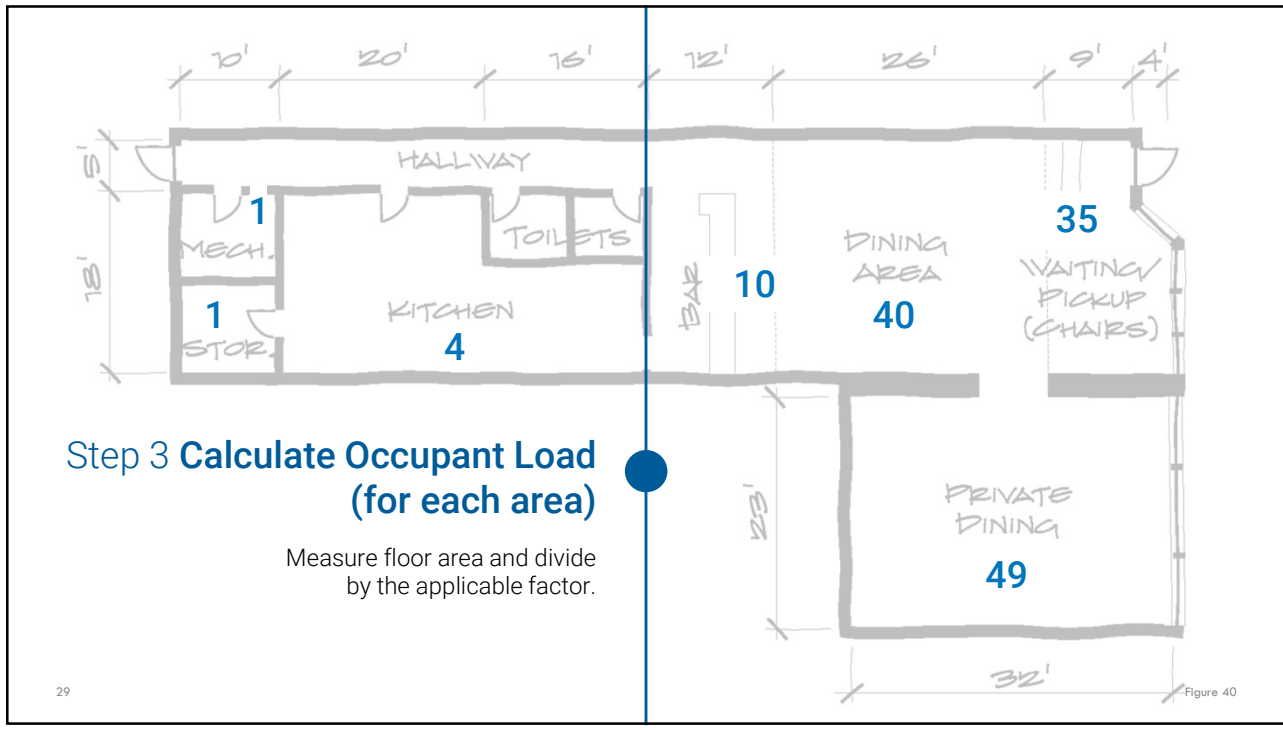

29



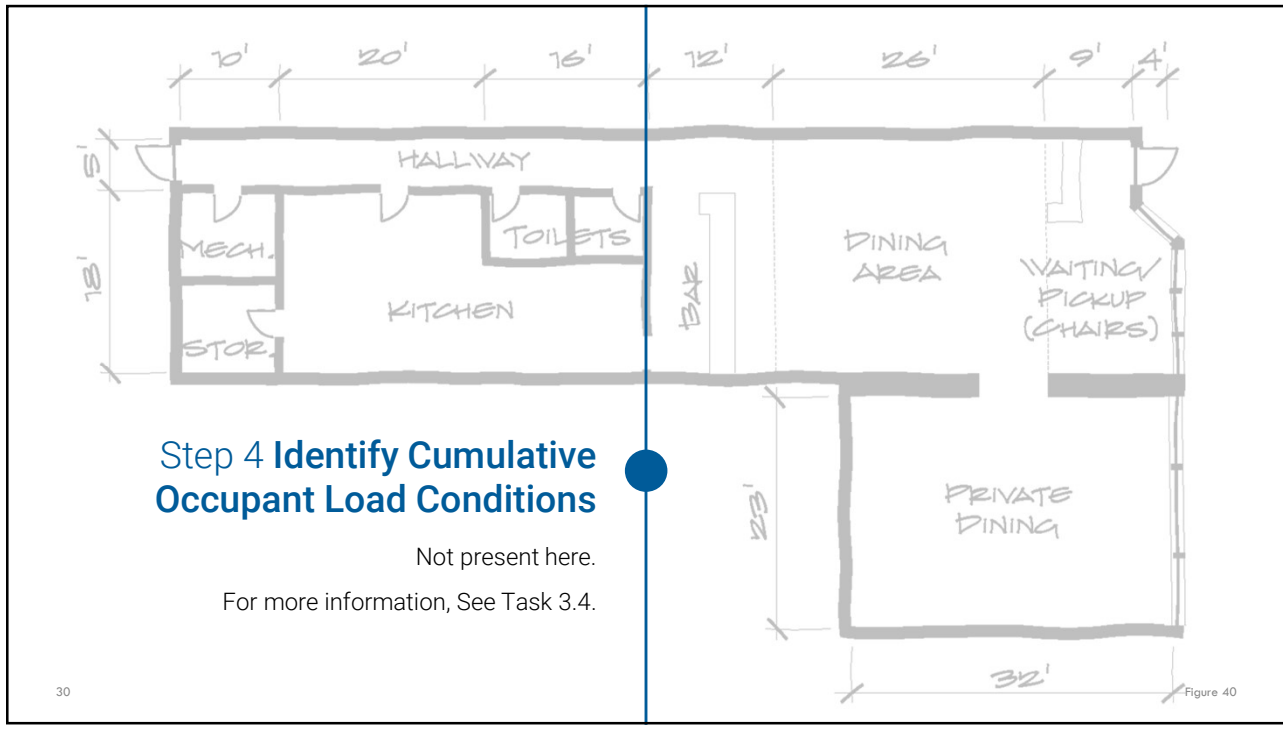

30

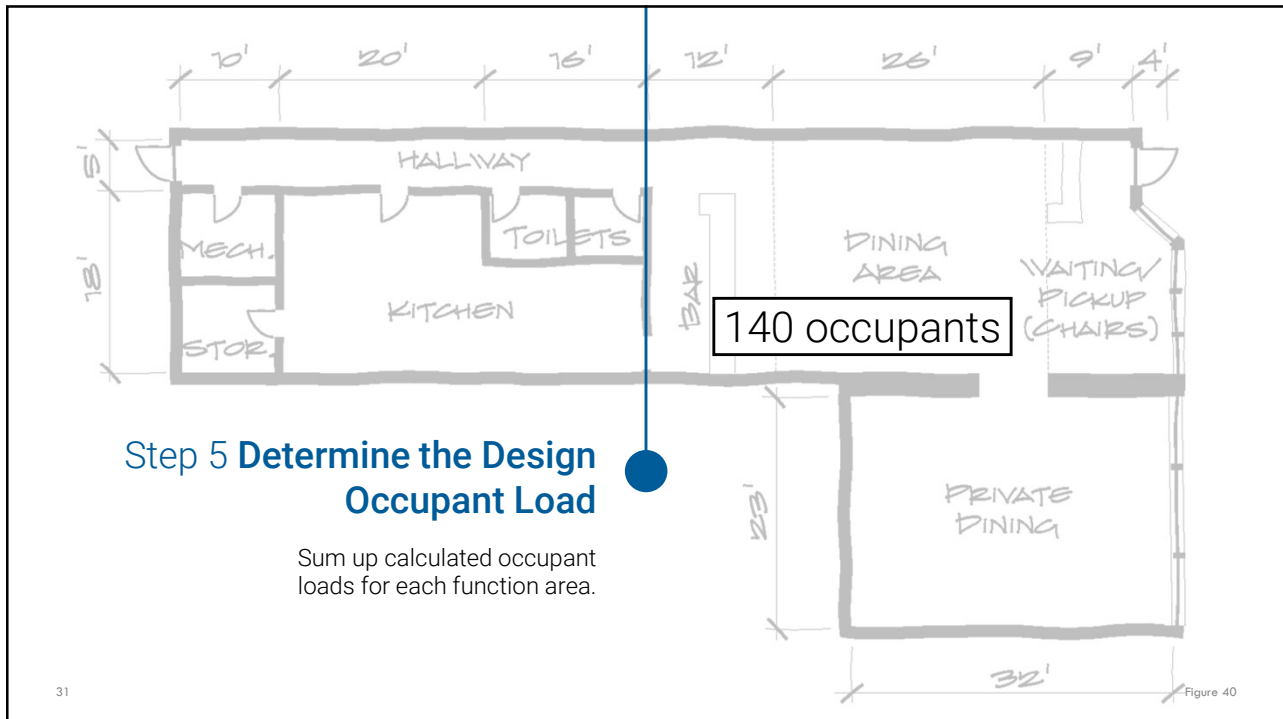

31

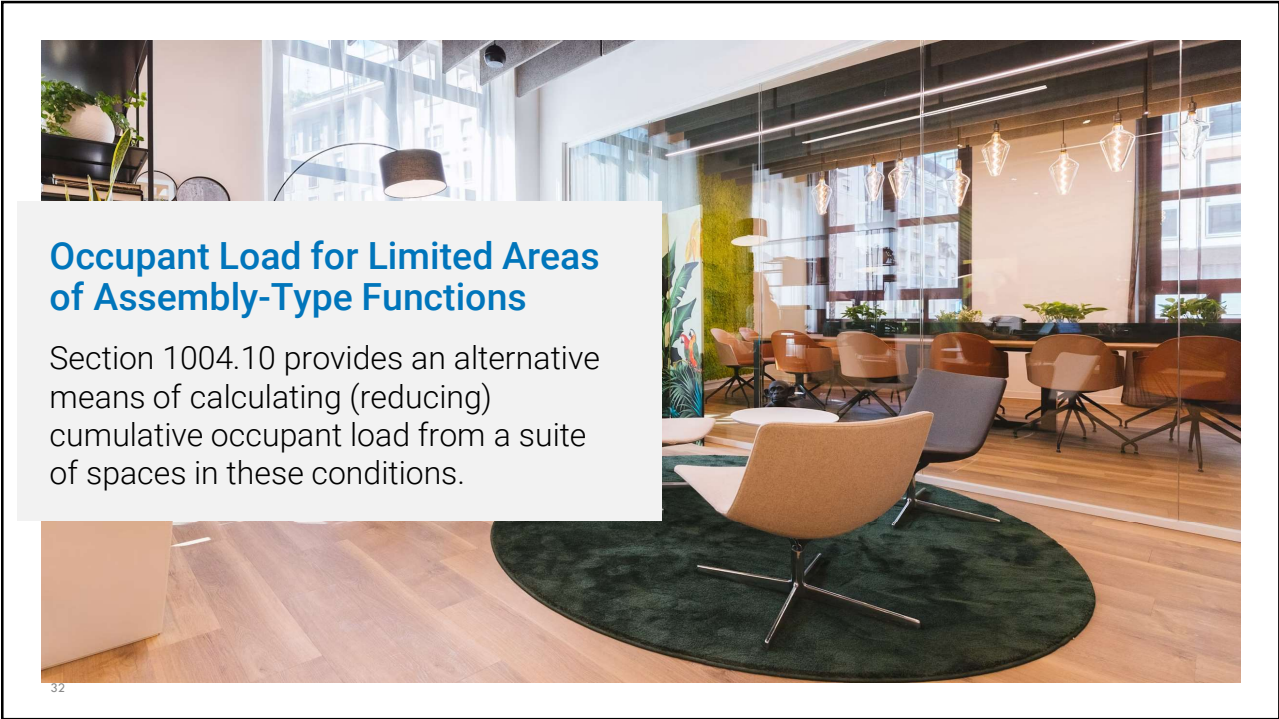

32

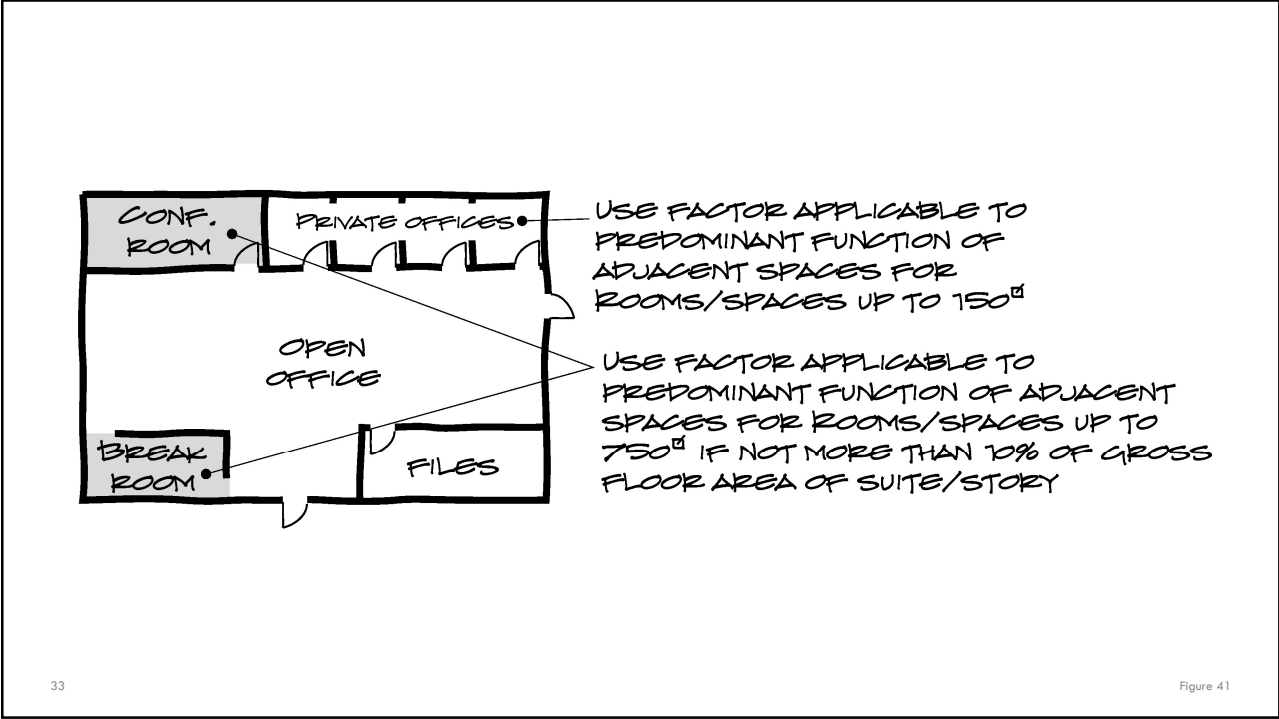

33

Figure 41



**Fixed Seating**  
Another special condition is fixed seating. Section 1004.6 addresses fixed seating—both individual seats and conditions like benches and booths.

34

34

slido



Audience Q&A Session

① Start presenting to display the audience questions on this slide.

35



## Independent Egress Routes

- Egress from stories/rooftops
- Egress from room/space
- Convergence

36

36



## Two Independent Routes

In most cases, two independent egress routes are required from both spaces and stories. There are limited exceptions. In some cases, spaces and stories with high occupant loads will require more than two egress routes.

**2**  
**F02**

37

37

## Check Quantity of Independent Egress Routes

38

38

### Step 1 Check Quantity of Egress Routes from Each Story and Occupiable Rooftop

- An egress route can be an **exit** or **access to an exit** on the story above or below.
- In most cases, at least **two** independent egress routes are required from a level.
- A story with an occupant load of 501 to 1,000 is required to have **three**.\*
- Every **habitable space** on the level must connect to at least the required number of routes.

39

39



Step 1.1 **Count exits from the story or occupiable rooftop.**

- Exits from the story can include exit stairs, exit ramps, horizontal exits (to another building), and exterior exit doors (at the level of exit discharge)
- Interlocking or scissor stairs count as a single exit.
- Do not count horizontal exits that lead to the same story in the same building. These do not count as exits from the story.

40

40

Step 1.2 **Count access to exits on other stories.**

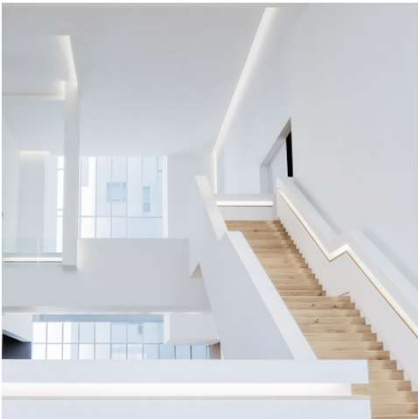

- In most cases, exit access stairways or ramps must provide access to an exit no more than one story above or below.
- Exceptions include:
  - Within Group R dwelling units
  - Group S-2 open parking garages
  - Group A occupancies with open-air seating or balconies, galleries, or press boxes

41

41

Step 1.3 Check single egress route from a story allowances.

- Section 1006.3.3 specifies **nine** conditions where a single egress route from a story is permissible.
- **Three** additional exceptions related to outdoor areas are listed in Section 1004.7.
- (So, there are **twelve** in total.)
- **Seven** of these only apply to residential occupancies.
- **Five** apply to all occupancies.

42

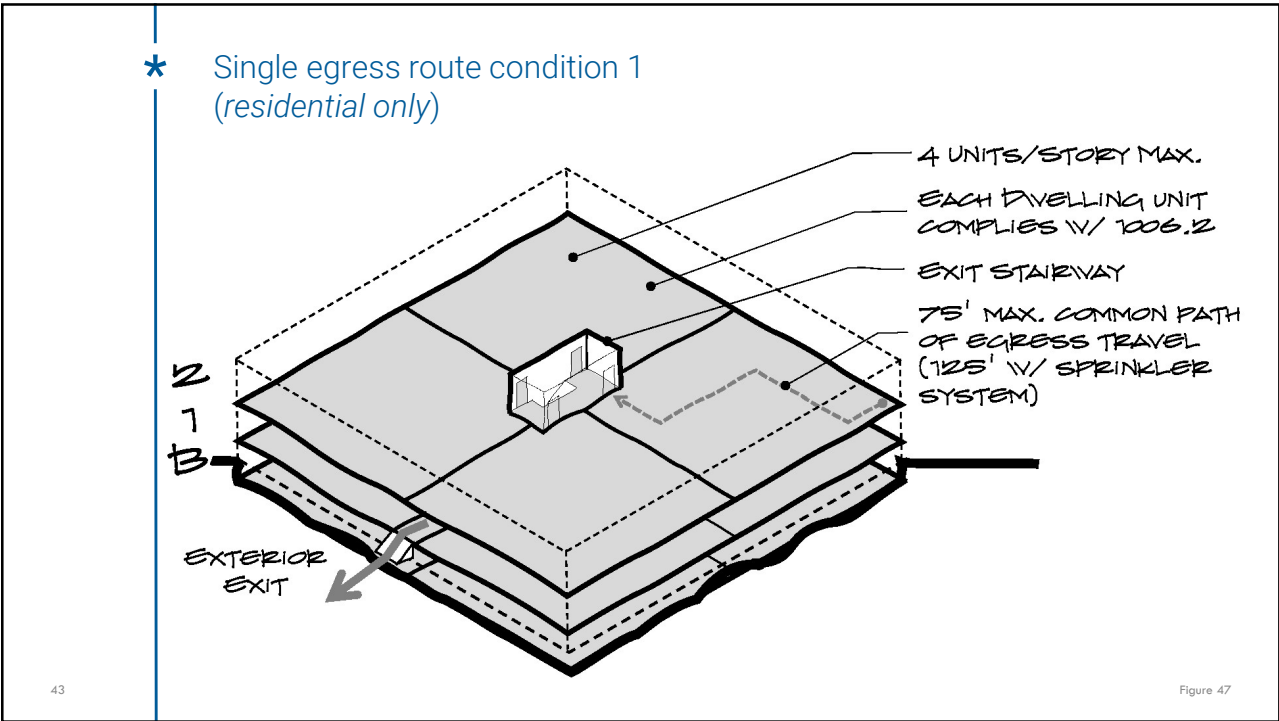

43

\* Single egress route condition 6  
(residential only)

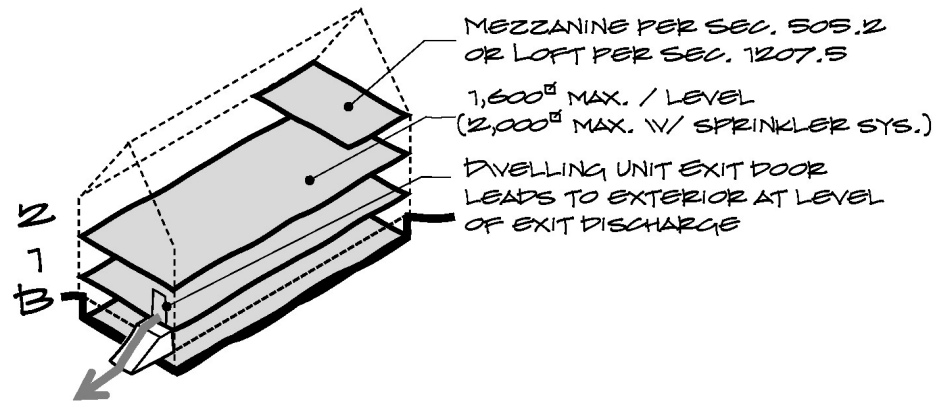

44

Figure 48

44

\* Single egress route condition 7  
(residential only)

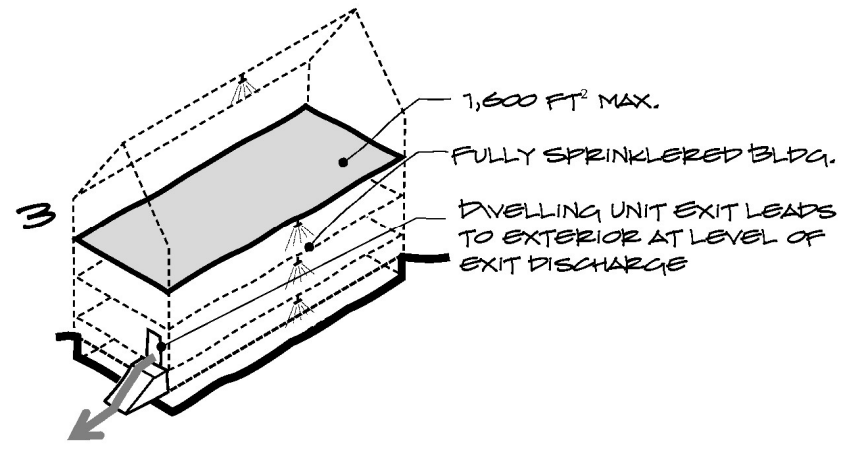

45

Figure 49

45

\* Single egress route condition 8 (residential only)

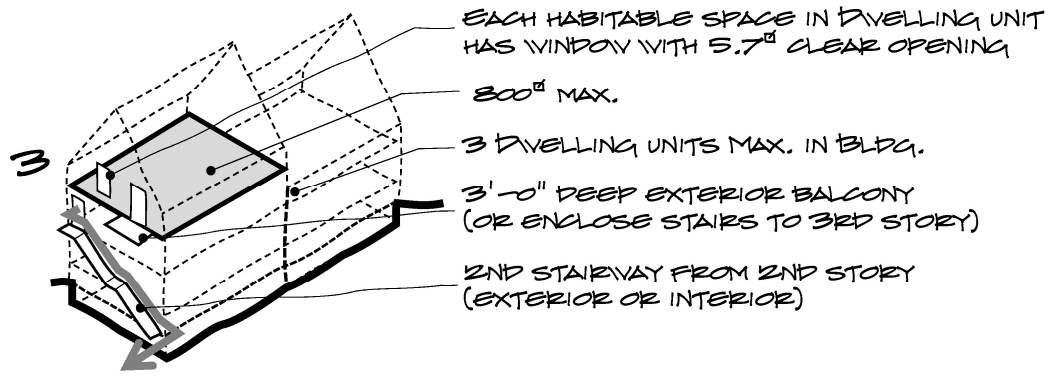

46

Figure 50

46

\* Single egress route condition 9 (residential only)

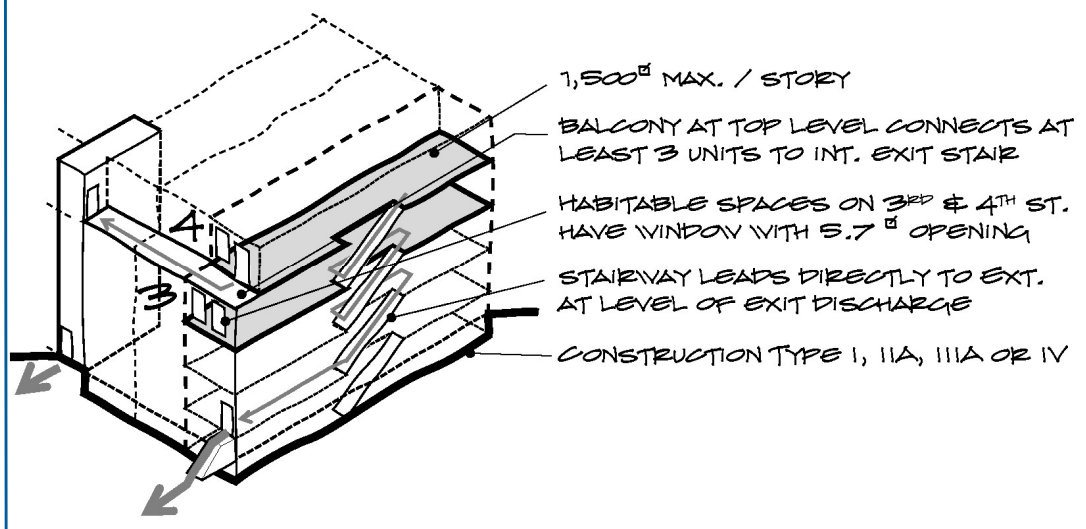

47

Figure 51

47

\* Single egress route condition 13(2)  
(residential only)

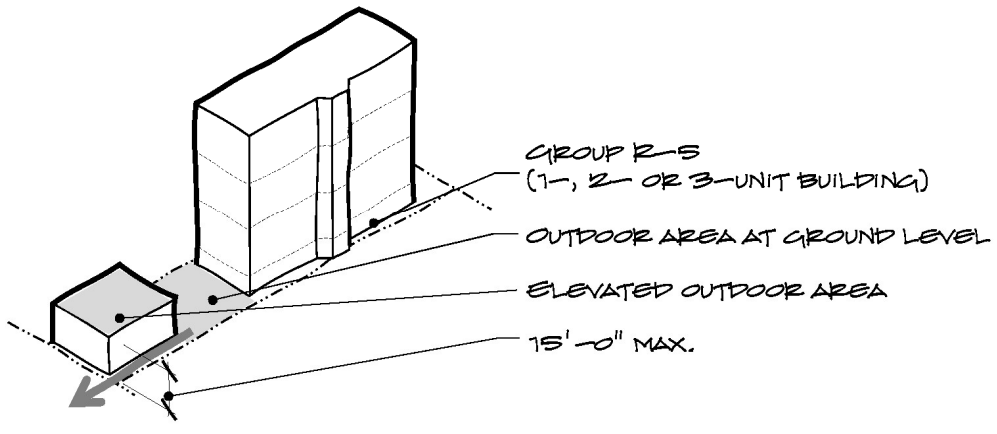

48

Figure 53

48

\* Single egress route condition 13(3)  
(residential only)

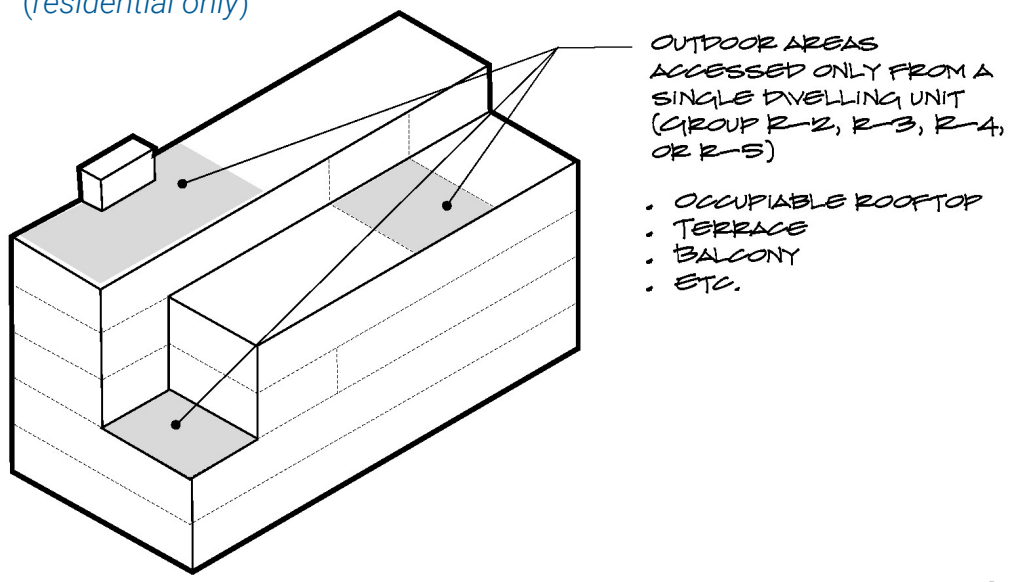

49

Figure 54

49



\* Single egress route condition 2  
 (all occupancies)

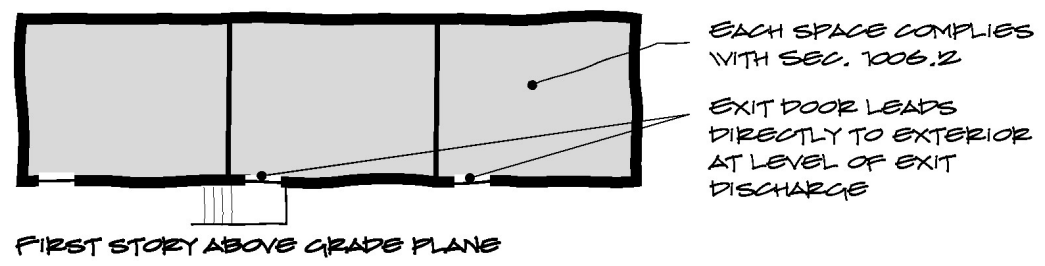

50

Figure 55

50

\* Single egress route condition 10  
 (all occupancies)

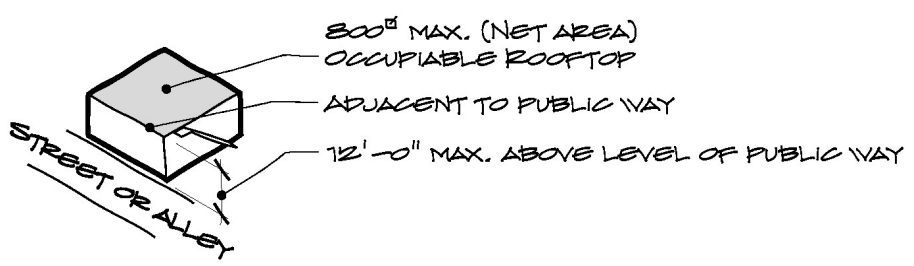

51

Figure 56

51

\* Single egress route condition 11  
(all occupancies)

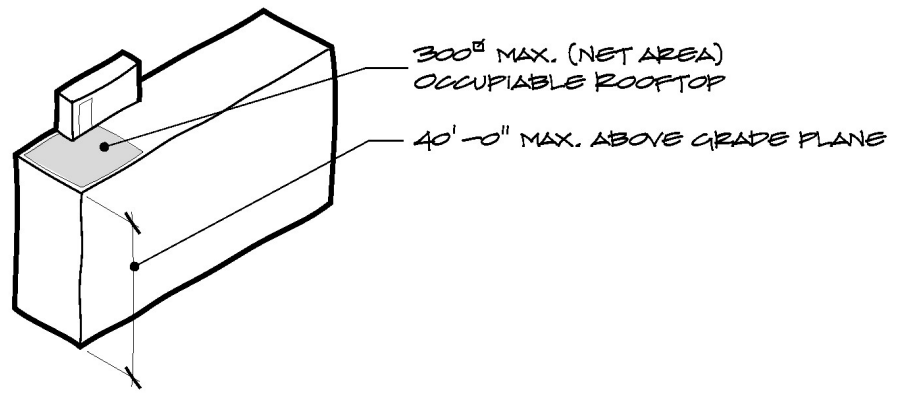

52

Figure 57

52

\* Single egress route condition 12  
(all occupancies)

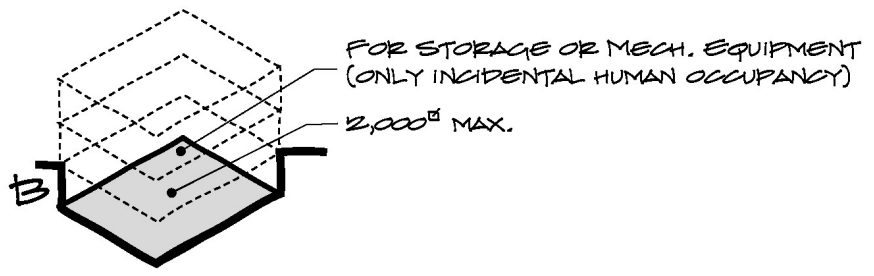

53

Figure 58

53

\* Single egress route condition 13(1)  
(all occupancies)

54

Figure 59

54

**Step 2 Check Quantity of Independent Egress Routes from Each Room or Space.**

- For levels required to have two or more independent egress routes, review each room or space on that level in this step.

**Step 2.1 Check requirement based on floor area.**

- Any room or space that exceeds 4,000 square feet gross floor area requires at least two independent egress routes.

55

55

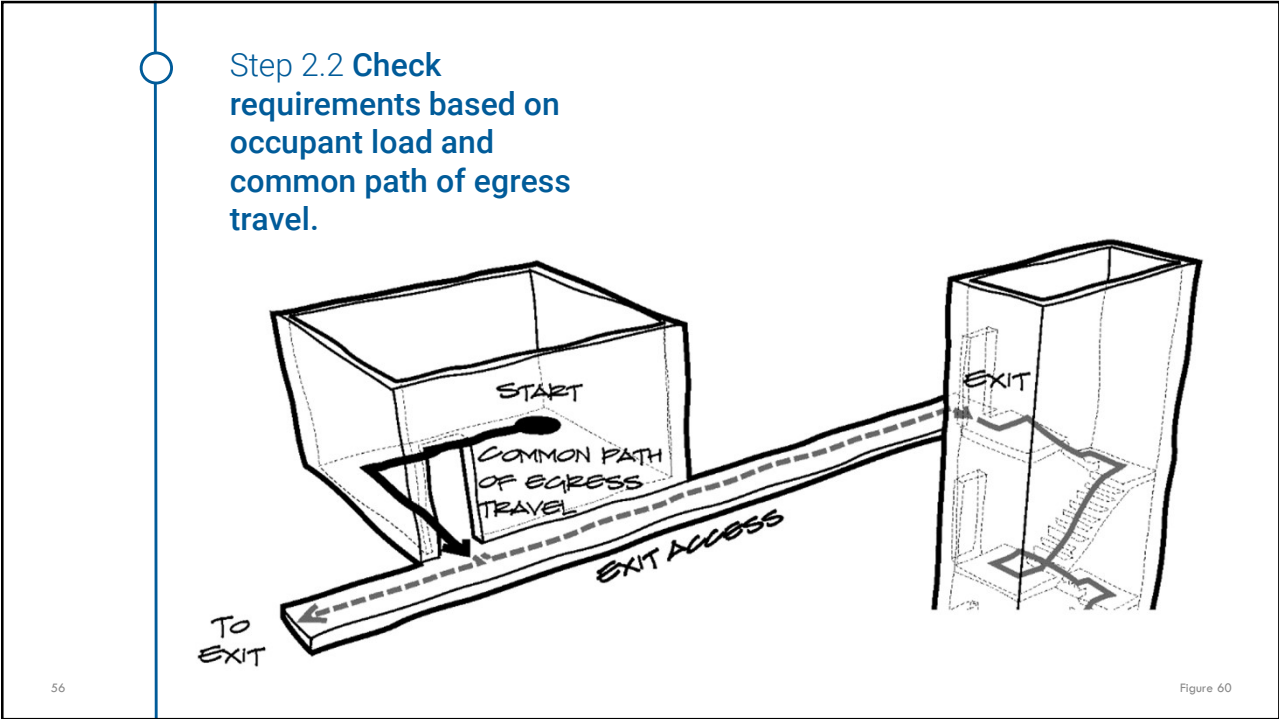

56

Figure 60

56

**TABLE 1006.2.1  
SPACES WITH ONE EXIT OR EXIT ACCESS DOORWAY**

OCCUPANCY	MAXIMUM OCCUPANT LOAD OF SPACE	MAXIMUM COMMON PATH OF EGRESS TRAVEL DISTANCE (feet)	
		Without Sprinkler System (feet)	With Sprinkler System (feet)
A <sup>c</sup> , E	49	75	75 <sup>a</sup>
B, M	49	75	115 <sup>a</sup>
F	49	75	115 <sup>a</sup>
H-1, H-2, H-3	3	NP	25 <sup>b</sup>
H-4, H-5	10	NP	75 <sup>b</sup>
I-1, I-2 <sup>d</sup> , I-4	10	NP	75 <sup>a</sup>
I-3	10	NP	100 <sup>a</sup>
R-1	10 <sup>h</sup>	60	75 <sup>i</sup>   115 <sup>a</sup>
R-2	10 <sup>h</sup>	60	75 <sup>i</sup>   115 <sup>a</sup>
R-3 <sup>e</sup> , R-5 <sup>e</sup>	10 <sup>h</sup>	60	75 <sup>h, i</sup>   115 <sup>a</sup>
R-4 <sup>e</sup>	10 <sup>h</sup>	60	75 <sup>h, i</sup>   115 <sup>a</sup>
S <sup>f</sup>	29	75	115 <sup>a</sup>
U	49	75	75 <sup>a</sup>

For SI: 1 foot = 304.8 mm, 1 square foot = 0.0929 m<sup>2</sup>.

57

57

\* Example: Group R dwelling unit

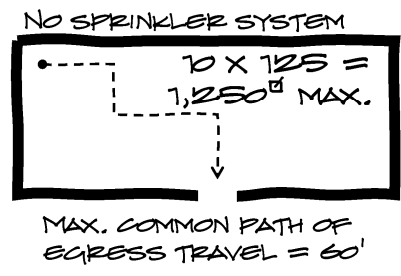

MAX. COMMON PATH OF EGRESS TRAVEL = 60'

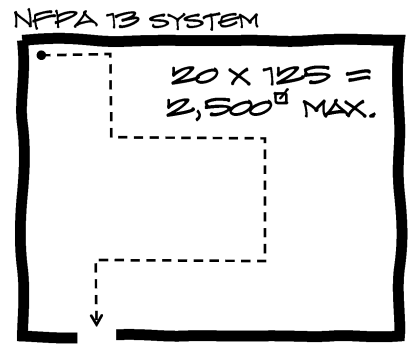

MAX. COMMON PATH OF EGRESS TRAVEL = 115'

58

Figure 61

58

Step 2.3 Check requirements based on use.



Section 1006.2.2 specifies several types of spaces with egress requirements based on function:

- Certain boiler, incinerator, and furnace rooms
- Certain refrigeration machinery rooms
- Certain refrigerated rooms
- Certain rooms in Group I-4 (daycare) occupancies
- Certain electrical equipment rooms

59

59



**Step 3 Confirm That Egress Routes Do Not Converge.**

Step 3.1 Check for exit access convergence.

Step 3.2 Check for exit discharge convergence.

O.L. > 49

EGRESS ROUTE CONVERGENCE PROHIBITED

60

Figure 62

60

slido

Audience Q&A Session

① Start presenting to display the audience questions on this slide.

61



**Separation of Egress Components**

- Where is separation required?
- Measuring separation
- Checking for separation

62

62

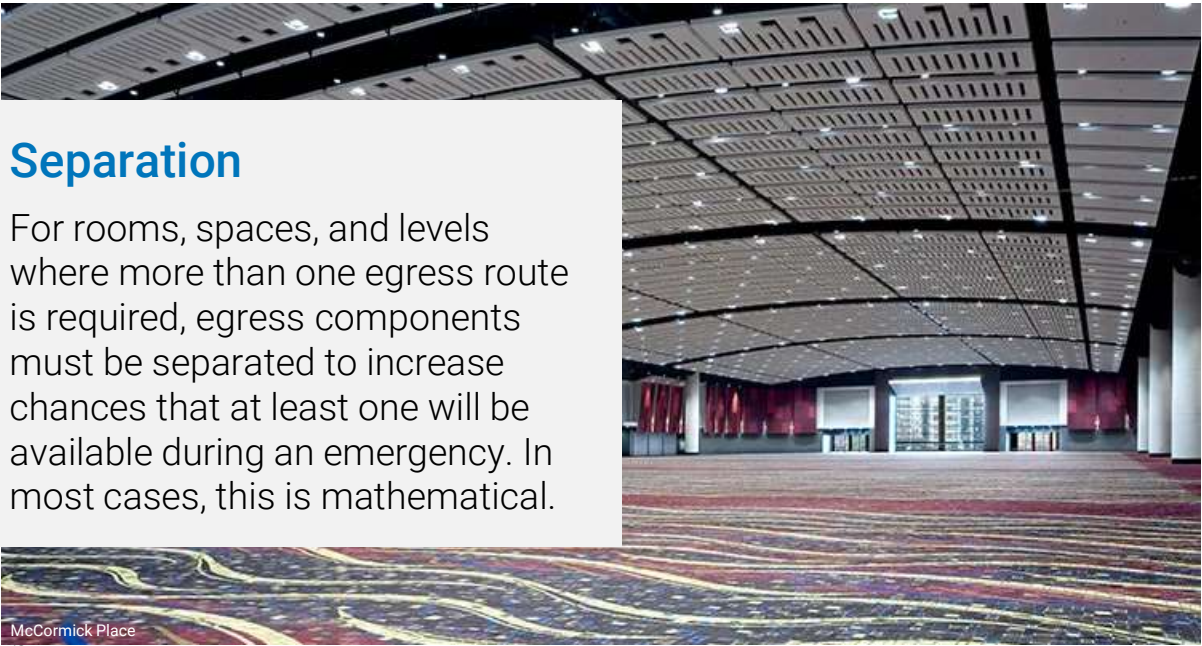

**Separation**

For rooms, spaces, and levels where more than one egress route is required, egress components must be separated to increase chances that at least one will be available during an emergency. In most cases, this is mathematical.

McCormick Place  
63

63

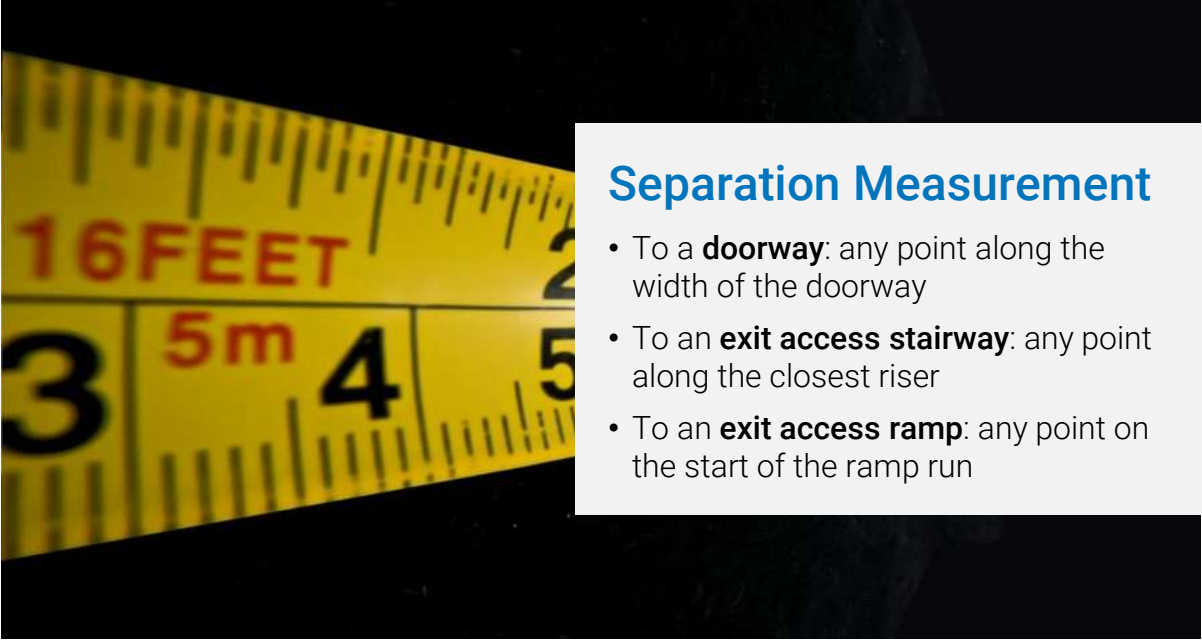

**Separation Measurement**

- To a **doorway**: any point along the width of the doorway
- To an **exit access stairway**: any point along the closest riser
- To an **exit access ramp**: any point on the start of the ramp run

64

64

**Check Separation of Egress Components**

65

65

**Step 1 Check Separation for Rooms or Spaces Required to Have Two or More Independent Egress Routes.**

- In most cases, required separation is a fraction of the diagonal (1/2 or 1/3).
- Exceptions apply for:
  - Group R-5
  - Within dwelling/sleeping units
  - Group B or M tenant spaces with 1-hour separations
  - Group R-2, fully sprinklered

66

66

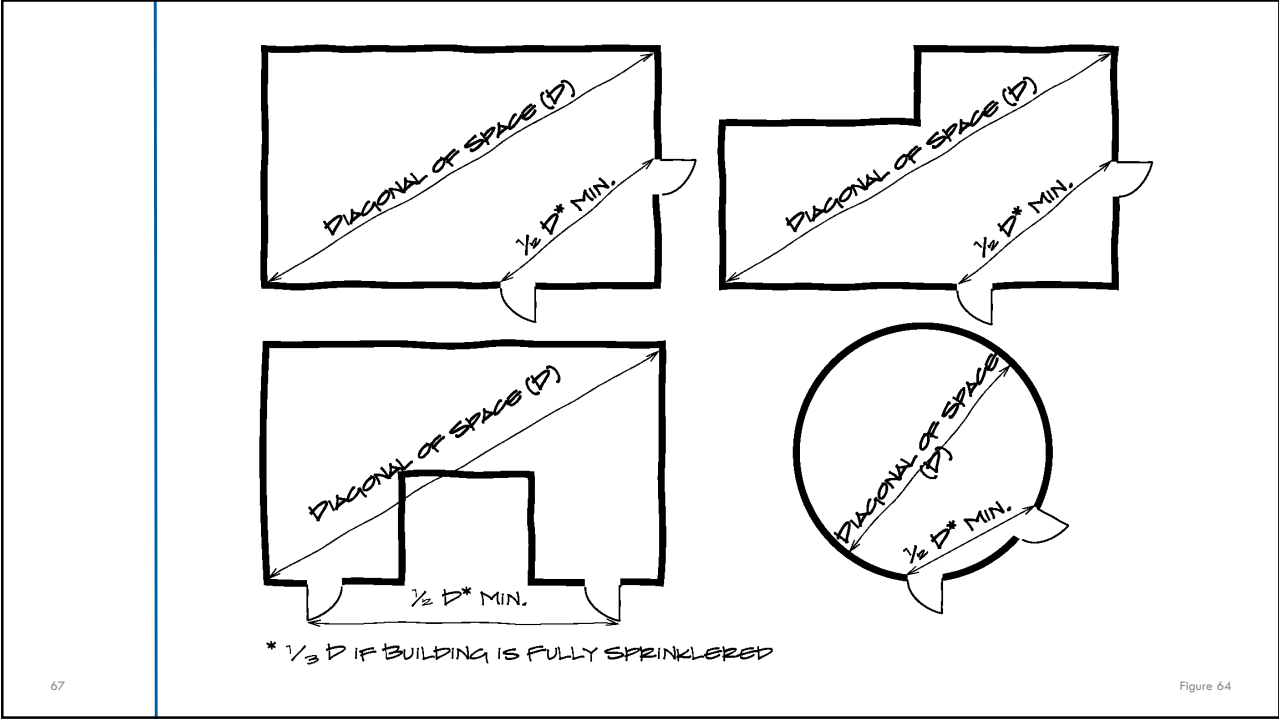
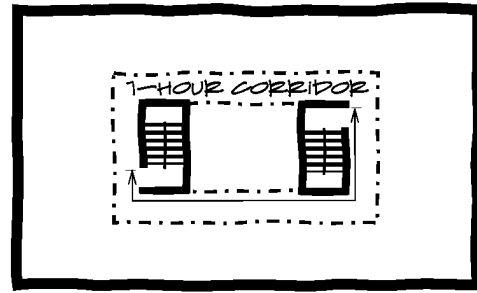
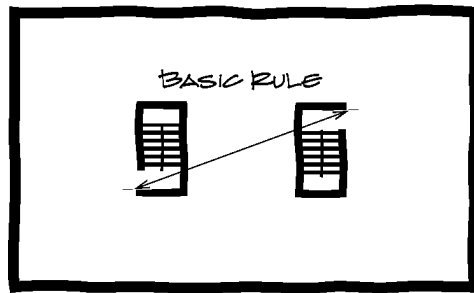

Figure 64

67

**Step 2 Check Separation for Stories or Occupiable Rooftops Required to Have Two or More Independent Egress Routes.**

- Non-rated corridors
- 1-hour corridors
- Special rule for Group R-2, fully sprinklered building



68

Figure 65

68

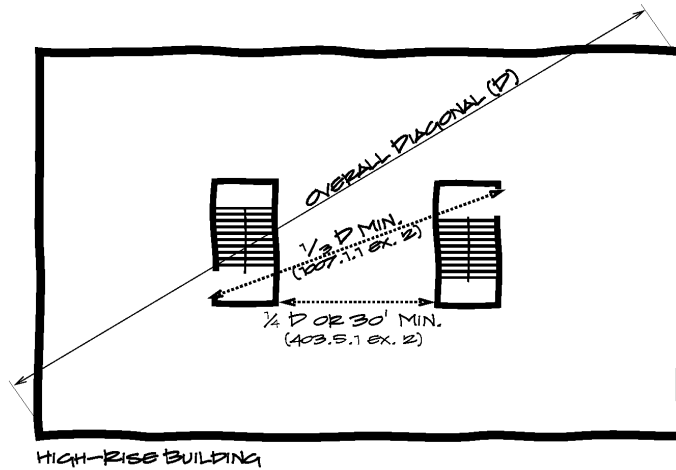

**Step 3 Check Special Exit Separation Requirements for High-Rise Buildings.**

- In high-rise buildings, an additional exit separation rule applies. (See Task 2.7)

69

Figure 32

69



**slido**



## Audience Q&A Session

① Start presenting to display the audience questions on this slide.

70

## Size and Capacity of Egress Components

- Purpose
- Minimum width
- Required capacity



71

71

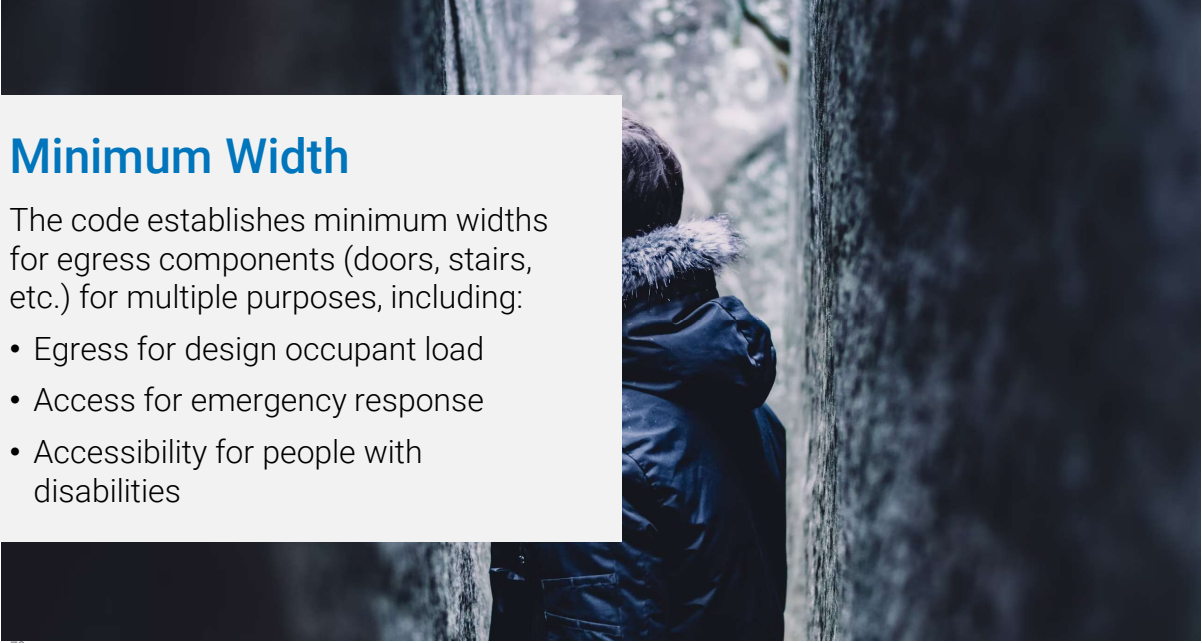

### Minimum Width

The code establishes minimum widths for egress components (doors, stairs, etc.) for multiple purposes, including:

- Egress for design occupant load
- Access for emergency response
- Accessibility for people with disabilities

72



73

A slide with a white background and a black border. On the left side, there is a blue rectangular box containing the text "Check Size and Capacity of Egress Components" in white. A thin blue horizontal line extends from the right side of this box across the width of the slide.

74

74

A slide with a white background and a black border. On the left side, there is a blue circle connected to a vertical blue line that extends down to the bottom of the slide. A horizontal blue line extends from the left edge of the slide to the circle. To the right of the circle, the text "Step 1 Gather Basic Information About the Building and Space." is written in blue. Further to the right, there is a paragraph of text and a bulleted list.

75

75

To review the size and capacity of the means of egress, you must know:

- Occupancy classification
- Design occupant load
- Sprinkler protection

**Step 2 Check Size and Capacity of Egress Components.**

- Clear width, height, and operation of doorways
- Clear width and headroom for stairs and ramps
- Clear width and ceiling height for aisles and corridors

**Step 2.1 Determine the clear width of each component.**  
 (And check for minimum width.)

See Tasks 3.5 and 3.7 in Plan Review Manual for minimum width.

76

76

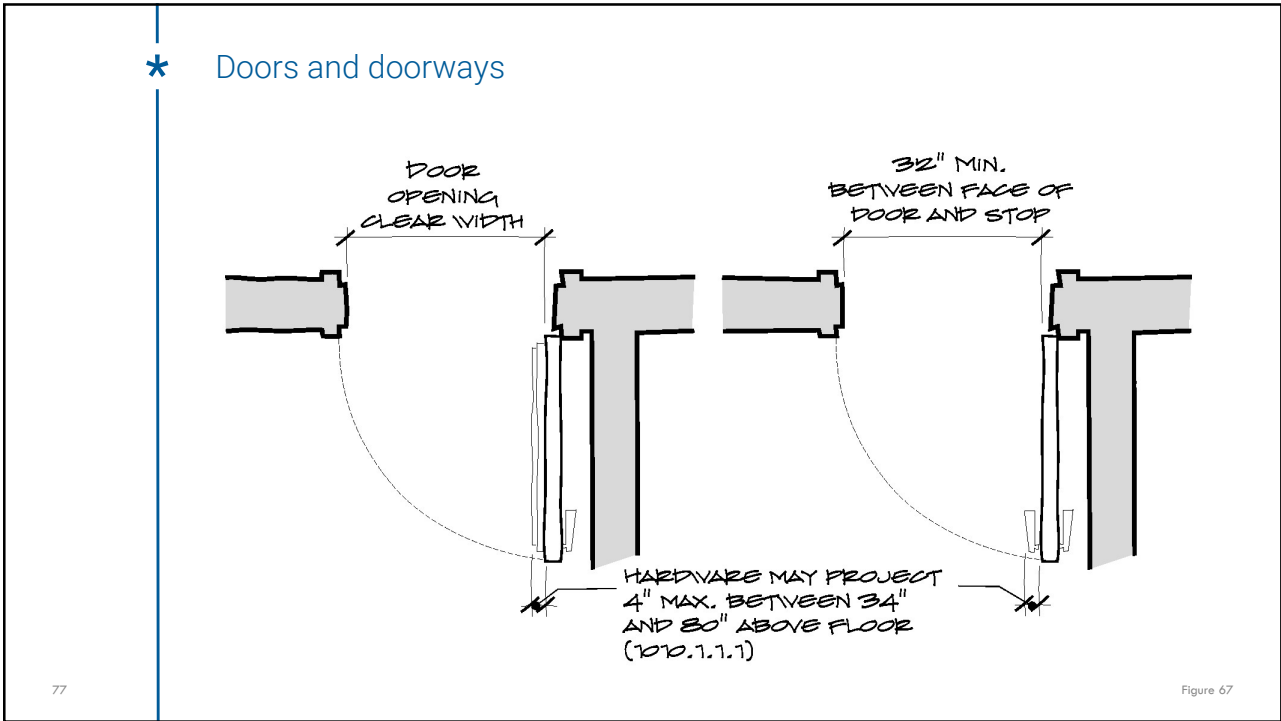

77

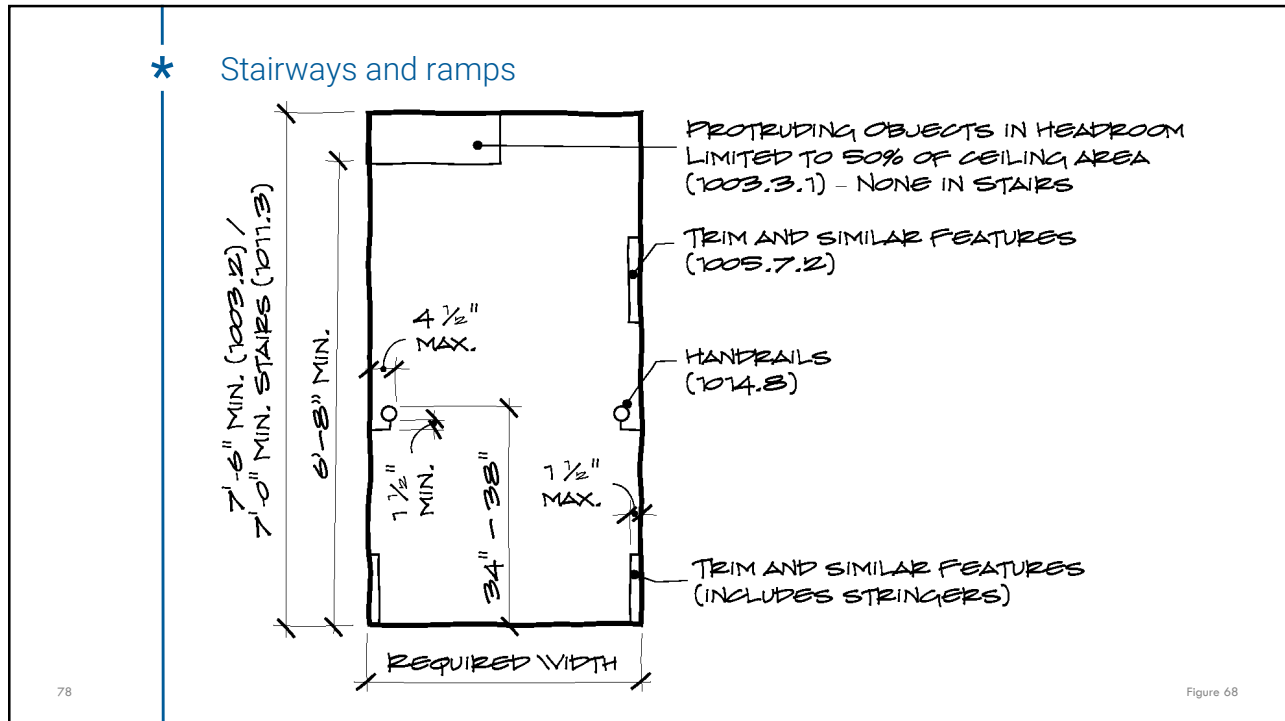

78

\* Aisles and corridors

- Minimum width based on occupancy (Table 1020.2)
- Handrails (similar to stairs/ramps)
- Trim (similar to stairs/ramps)
- Hardware (similar to doors)

Step 2.2 Determine if egress components are adequately sized for the design occupant load.

- Divide by appropriate factor:

Capacity of Egress Components		
Component Type	NFPA 13 or 13R system throughout building	
	No	Yes <sup>a</sup>
Stairway	0.3 inch / occupant	0.2 inch / occupant
Indoor assembly seating aisles	See Section 1029.6.1	
Open air assembly seating aisles	See Section 1029.6.3	
Assembly aisle accessways	See Section 1029.13	
Other egress component (Doors, gates, etc.)	0.2 inch / occupant	0.15 inch / occupant

a. Use non-sprinklered factor for Group H and I-2 occupancies.

79

79



**Step 2.3 Check for distribution of egress capacity.**

Where more than one independent egress route is required, the means of egress system must be configured so that loss of any one egress route will not reduce the available capacity or width to less than 50% of the required capacity or width.

80 Figure 69

80

**Step 2.4 Check for convergence of egress routes.**

Beyond points of convergence, size for the larger of the capacity based on minimum width or required capacity.

O.L. = 200  
60" stair capacity = 200

O.L. = 75  
44" stair capacity = 146

EGRESS FROM FIRST STORY ABOVE GRADE

EGRESS FROM BASEMENT

EXIT AT GRADE

Size door for **346** (200 + 146), not 275 (200 + 75).

81 Figure 70

81

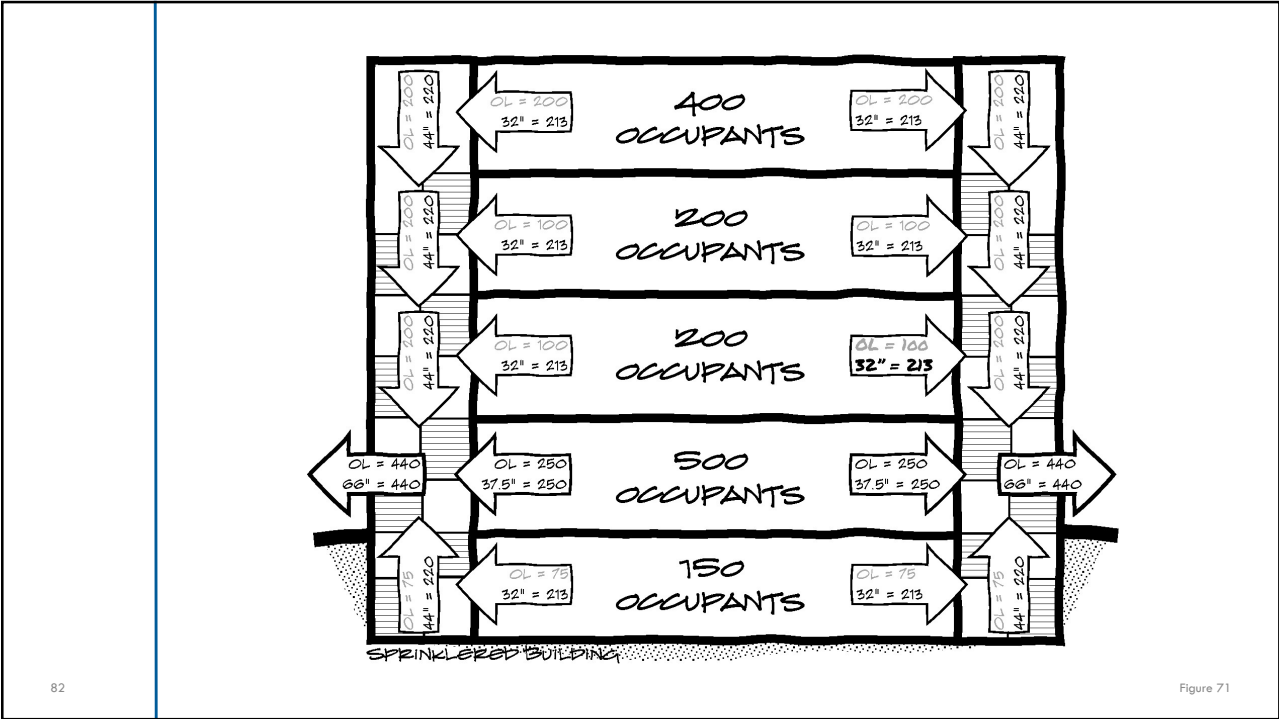

82

Figure 71

82

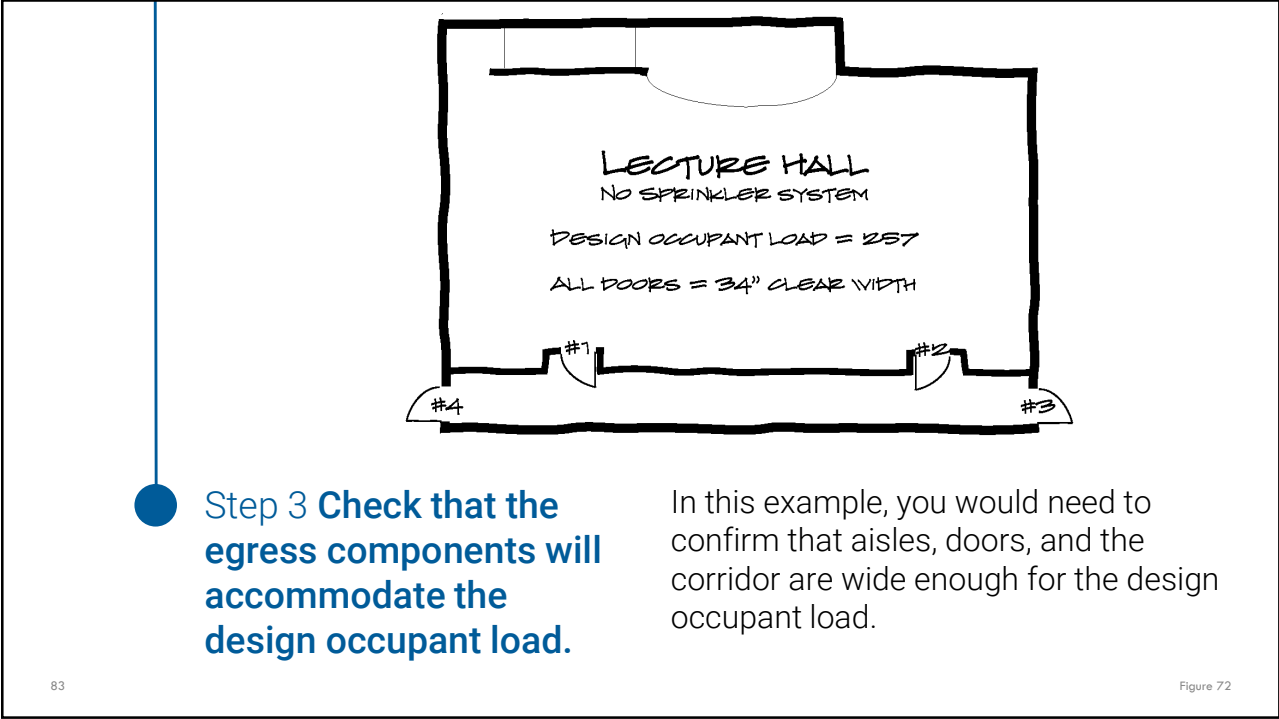

83

Figure 72

83

Step 3 Check that the egress components will accommodate the design occupant load.

In this example, you would need to confirm that aisles, doors, and the corridor are wide enough for the design occupant load.

slido



## Audience Q&A Session

① Start presenting to display the audience questions on this slide.

84

## Exit Access

What is it?  
What to check for



85

85



Aisle

Corridor

Exit access stairway

86

86

**Check Exit Access**

87

87

With limited exceptions, the egress path from a room or space cannot pass through an unrelated adjoining room or space.

**Step 1  
Check  
Egress  
Through  
Intervening  
Spaces.**

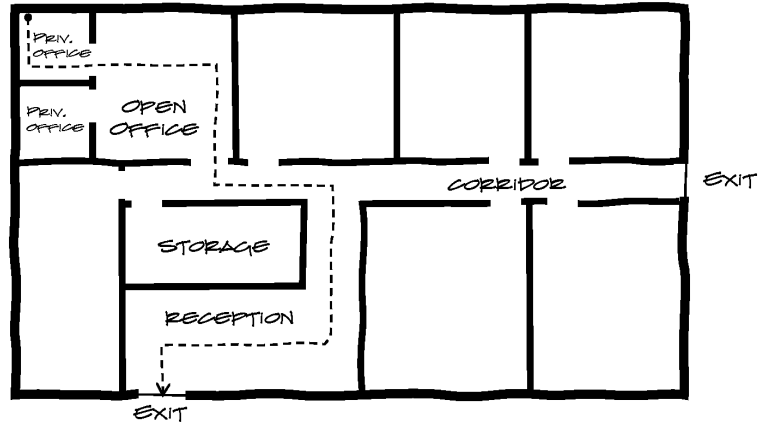

88

Figure 76

88

**Step 2 Check Exit  
Access Travel Distance.**

Exit access travel distance is measured from the most remote point in an occupiable room to the nearest exit.

**TABLE 1017.2  
EXIT ACCESS TRAVEL DISTANCE<sup>a</sup>**

OCCUPANCY	WITHOUT SPRINKLER SYSTEM (feet)	WITH SPRINKLER SYSTEM (feet)
A, E, F-1, M, R, S-1	200 <sup>c</sup>	250 <sup>b</sup>
I-1	Not Permitted	250 <sup>b</sup>
B	200	300 <sup>c</sup>
F-2, S-2, U	300	400 <sup>c</sup>
H-1	Not Permitted	75 <sup>d</sup>
H-2	Not Permitted	100 <sup>d</sup>
H-3	Not Permitted	150 <sup>d</sup>
H-4	Not Permitted	175 <sup>d</sup>
H-5	Not Permitted	200 <sup>c</sup>
I-2, I-3	Not Permitted	200 <sup>c</sup>
I-4	150	200 <sup>c</sup>

89

89





Exit access travel is measured along the **“natural and unobstructed”** path of travel.

90 Figure 77

90

**Step 3 Check Exit Access Corridor Requirements.**

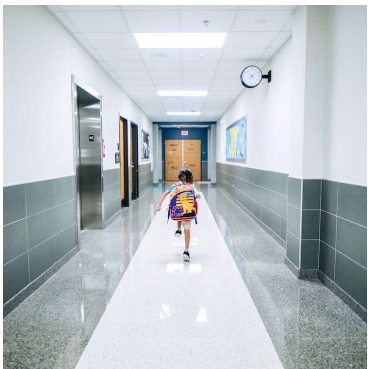

A corridor is “[a]n enclosed exit access component that defines and provides a path of egress travel.” Generally, there is no requirement to provide corridors (instead of unenclosed aisles), however when a corridor is provided, it must meet certain requirements.

91

91

○

**Step 3.1 Check fire-resistance rating.**

In some cases, corridors are required to have a fire-resistance rating.

**TABLE 1020.1**  
**CORRIDOR FIRE-RESISTANCE RATING**

OCCUPANCY	OCCUPANT LOAD SERVED BY CORRIDOR	REQUIRED FIRE-RESISTANCE RATING (hours)	
		Without sprinkler system	With sprinkler system
H-1, H-2, H-3	All	Not Permitted	1
H-4, H-5	Greater than 30	Not Permitted	1
A, B, F, M, S, U	Greater than 30	1	0 <sup>e</sup>
E	All	1	1
R	Greater than 10	1	1
I-2 <sup>a</sup>	All	Not Permitted	0
I-1, I-3	All	Not Permitted	1 <sup>b</sup>
I-4	All	1	0

a. For requirements for occupancies in Group I-2, see Sections 407.2 and 407.3.

b. For a reduction in the *fire-resistance rating* for occupancies in Group I-3, see Section 408.8.

c. [Reserved]

d. [Reserved]

e. In Groups A-1, A-2, A-3 and A-4 occupancies, *corridors* serving and visually separated from a room or suite of rooms with an *occupant load* of 300 or more shall have a *fire-resistance rating* of not less than 1 hour.

92

92

○

**Step 3.2 Check minimum width.**

When corridors are provided, there are also minimum clear width requirements:

**TABLE 1020.2**  
**MINIMUM CORRIDOR WIDTH**

OCCUPANCY	MINIMUM WIDTH (inches)
Any facility not listed in this table	44
Access to and utilization of mechanical, plumbing or electrical systems or equipment	24
With an <i>occupant load</i> of less than 50	36
Within or serving a single <i>dwelling unit</i>	36
In Group E-1 <i>corridors</i> serving classrooms, study rooms or assembly rooms	60 <sup>a</sup>
In <i>corridors</i> and areas serving stretcher traffic in <i>ambulatory care facilities</i>	72
Group I-2 in areas where required for bed movement	96

For SI: 1 inch = 25.4 mm.

a. When lockers are installed in corridors, the full required clear width of the corridor shall be provided between locker doors when open.

93

93

**Step 3.3 Check encroachments.**

Doors opening into corridors must meet requirements for door swing and hardware projection.

\* FULL WIDTH Req'd IN GROUP E-1

94 Figure 78

94

7'-6" MIN. (1003.2) / 7'-0" MIN. STAIRS (1011.3)

6'-8" MIN.

4 1/2" MAX.

1 1/2" MIN.

34" - 38"

1 1/2" MAX.

REQUIRED WIDTH

PROTRUDING OBJECTS IN HEADROOM LIMITED TO 50% OF CEILING AREA (1003.3.1) - NONE IN STAIRS

TRIM AND SIMILAR FEATURES (1005.7.2)

HANDRAILS (1014.8)

TRIM AND SIMILAR FEATURES (INCLUDES STRINGERS)

95 Figure 68

95

Step 3.4 Check dead ends.

A dead-end condition exists if an occupant has only one direction to travel to reach an exit in a corridor or in part of the exit discharge.

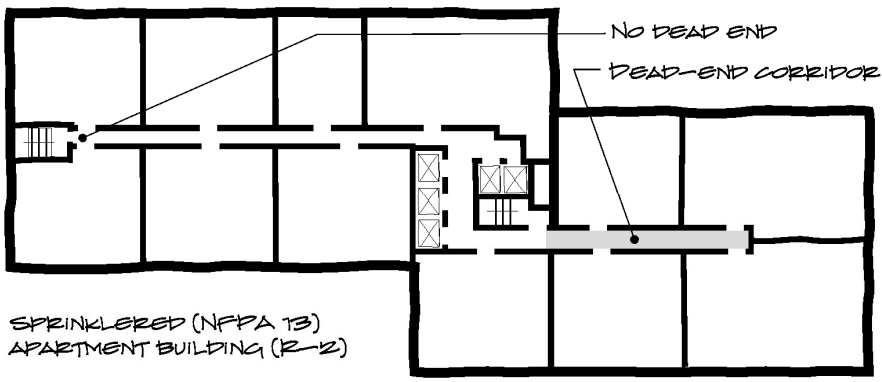

96

Figure 79

96

Step 3.5 Check air movement.

An exit access corridor generally must not be used as a conduit for the movement of air. The purpose of this requirement is to reduce the possibility that corridors are obstructed by smoke or fire in an emergency.

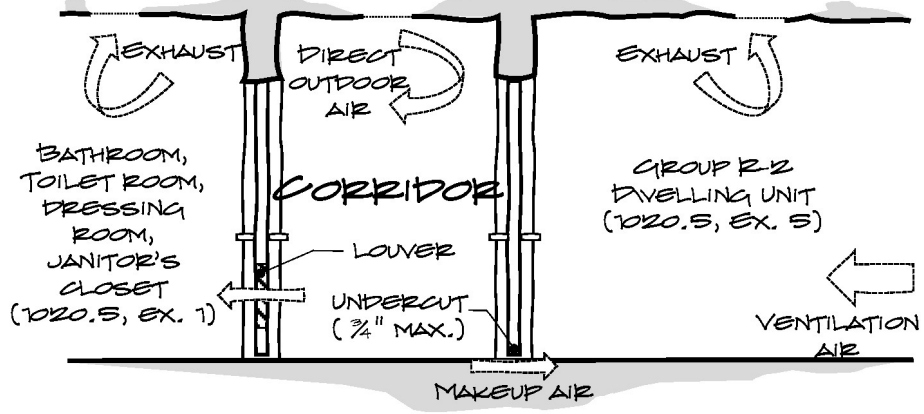

97

Figure 80

97

slido



Audience Q&A Session

① Start presenting to display the audience questions on this slide.

98



**Exits and Exit Discharge**

What is it?

What to check for

99

99

### Exit

That portion of a means of egress system between the exit access and the exit discharge or public way. Exit components include exterior exit doors at the level of exit discharge, interior exit stairways and ramps, exit passageways, exterior exit stairways and ramps, and horizontal exits.



100



Horizontal exit

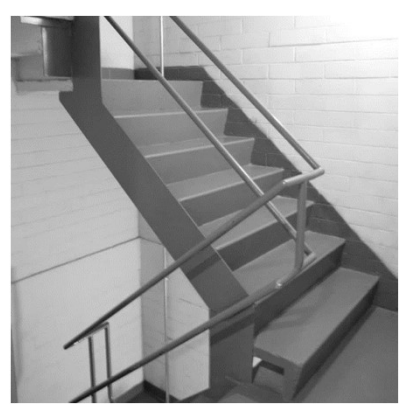

Exit stairway

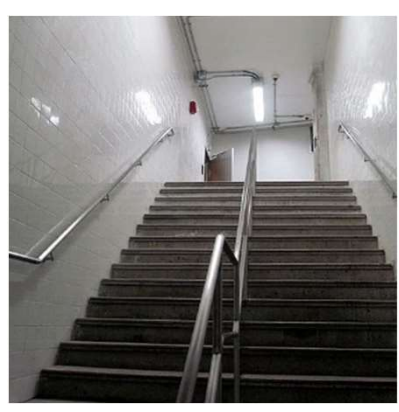

Exit stairway

101

101





**Exit Discharge**

That portion of a means of egress system between the termination of an exit and a public way.

- Can be indoors or outdoors

102

102

**Check Exits and Exit Discharge**

103

103

**Step 1 Check Interior Exit Stairways and Ramps.**

Interior exit stairways and ramps provide a **protected** vertical path of egress travel, **separated** from occupiable spaces by fire-resistance-rated construction with **limited openings** and penetrations.

104

104

**Step 1.1 Check interior exit enclosures.**

- Rated enclosure
- Limited openings
- Limited penetrations

105

Figure 83

105

Step 1.2 Check exterior walls of exit enclosures.

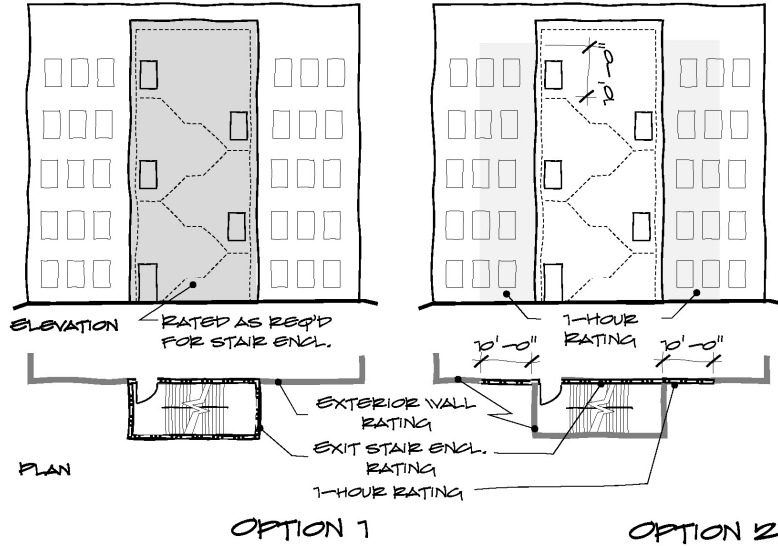

106

Figure 84

106

Step 1.3 Check door construction.

TABLE 716.1(2)  
OPENING FIRE PROTECTION ASSEMBLIES, RATINGS AND MARKINGS

TYPE OF ASSEMBLY	REQUIRED WALL ASSEMBLY RATING (hours)	MINIMUM FIRE DOOR AND FIRE SHUTTER ASSEMBLY RATING (hours)	DOOR VISION PANEL SIZE <sup>a</sup>	FIRE-RATED GLAZING MARKING DOOR VISION PANEL <sup>c, e</sup>	MINIMUM SIDELIGHT/TRANSOM ASSEMBLY RATING (hours)		FIRE-RATED GLAZING MARKING SIDELIGHT/TRANSOM PANEL	
					Fire protection	Fire resistance	Fire protection	Fire resistance
Fire walls and fire barriers having a required fire-resistance rating greater than 1 hour	4	See Note f.	Not Permitted	Not Permitted	Not Permitted	NP	Not Permitted	NP
	4 <sup>g</sup>	3 <sup>a</sup>	100 sq. in.	D-H-W-240	Not Permitted	4	Not Permitted	W-240
	3	3 <sup>a</sup>	100 sq. in.	D-H-W-180	Not Permitted	3	Not Permitted	W-180
	2	1½	100 sq. in. <sup>b</sup>	< 100 sq. in. = D-H-90 > 100 sq. in. = D-H-W-90	Not Permitted	2	Not Permitted	W-120
	1½	1½	100 sq. in. <sup>b</sup>	< 100 sq. in. = D-H-90 > 100 sq. in. = D-H-W-90	Not Permitted	1½	Not Permitted	W-90
Enclosures for shafts, interior exit stairways and interior exit ramps	2	1½	100 sq. in. <sup>b, c</sup>	< 100 sq. in. = D-H-90 > 100 sq. in. = D-H-T-W-90	Not Permitted	2	Not Permitted	W-120

107

107



### Step 1.4 Check discharge identification.

The level of exit discharge must be clear to users of the exit.

This may require signage or physical barriers.

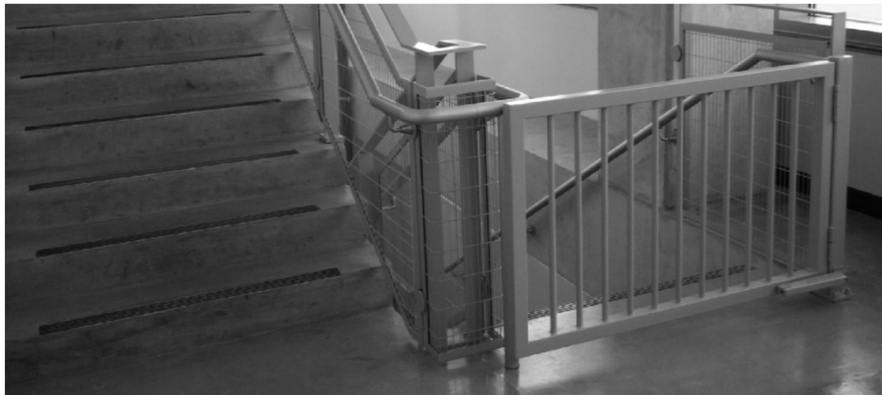

108

108



### Step 2 Check Exit Passageways.

Exit passageways connect multiple exits or provide a protected travel path on the level of exit discharge. Unlike exit access corridors, exit passageways are subject to stricter requirements in terms of construction, openings and penetrations, and interior finishes.

- Fire-resistance-rated enclosure
- Limited openings
- Limited penetrations

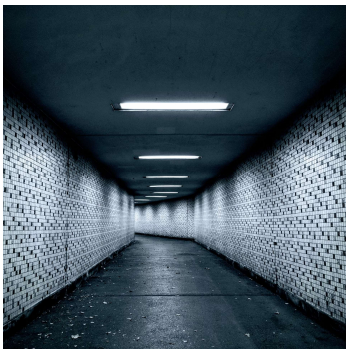

109

109

**Step 3 Check Horizontal Exits.**



A horizontal exit in a fire barrier allows passage to a fire-separated refuge areas within the same building.

A horizontal exit in a fire wall allows passage between separate buildings.

110

110

**Step 3.1 Check construction and configuration.**

- Horizontal exit may provide half of required exit capacity
- Fire barrier or fire wall
- Self- or automatic-closing

**Step 3.2 Check refuge areas.**

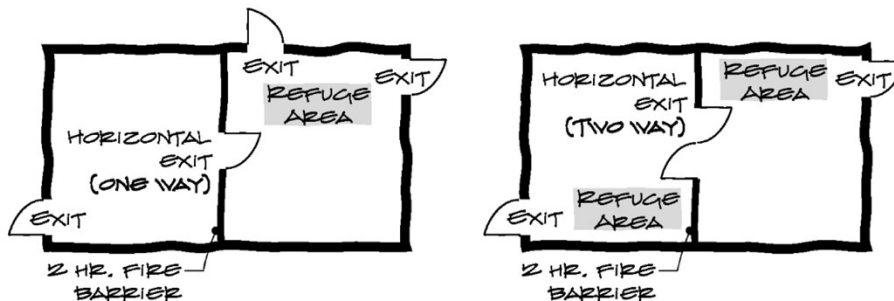

111

Figure 86

111

## Step 4 Check Exterior Exit Stairways and Ramps.

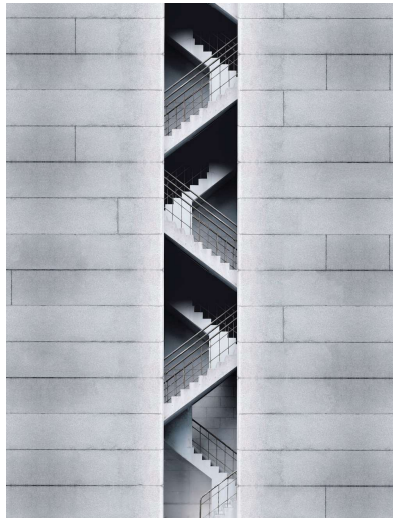

Stairways and ramps may be exit access, exit, or exit discharge components.

To qualify as an exit, exterior stairways must usually be **protected from exposure to fire** originating in the interior of the building and located away from abutting property lines.

Exceptions allow traditional Chicago **porches** to qualify as exterior exit stairways for non-transient residential buildings up to 4 stories.

112

112

## Step 5 Check Exit Discharge.



Exits must discharge directly to the exterior or meet one of three exceptions allowing for discharge to or through an interior space.

The exterior portion of the means of egress, between the exit and the public way, must also meet certain requirements.

113

113



**Step 5.1 Check discharge through level of exit discharge.**

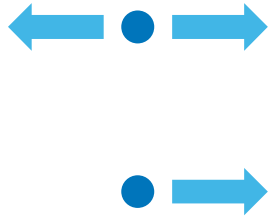

- Only allowed in fully-sprinklered building (NFPA 13 or NFPA 13R).
- Limitations on travel distance and turns.
- If **more than 50%** of exits discharge through the lobby, then each exit must have access to **two distinct exterior exit doors**.
- Where **up to 50%** of exits discharge through the lobby, each exit may have access to only **one** exterior exit door.

114

114

**Step 5.2 Check exit discharge through vestibules.**

Discharge through vestibules has dimensional limits and requires fire-rated construction.

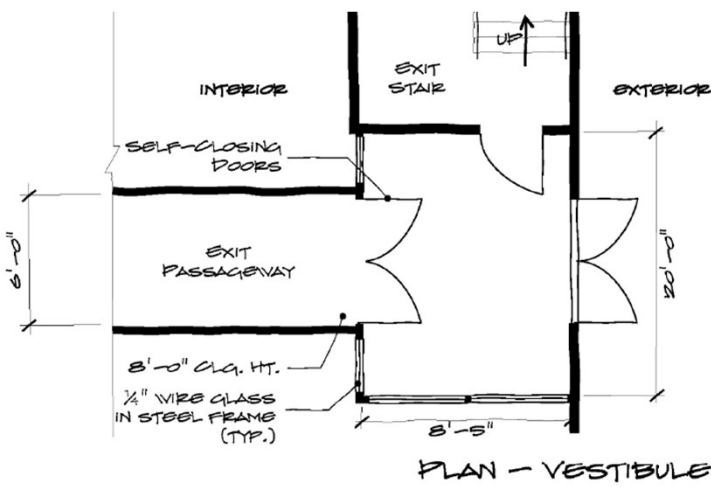

115

115

### Step 5.3 Check egress courts and exterior travel.



- In general, egress courts must be at least 44" wide. When they are less than 10 feet wide, they must have fire-rated walls and protected openings.
- Exceptions allow 36-inch-wide egress courts and omitting fire-resistance-rated walls for some residential-only buildings.

116

116



### Step 5.4 Check public way access.

The exit discharge must generally end at a point of unobstructed access to a public way (street, sidewalk, alley, etc.)

A limited exception allows key-locked gates for residential buildings with 4 or fewer units.

The code also provides an exception for sites without ready access to a public way, requiring a safe dispersal area instead (rare in Chicago)

117

117

slido



## Audience Q&A Session

① Start presenting to display the audience questions on this slide.

118

## Other Egress Requirements

See Task 3.7 for more information on egress components.



119

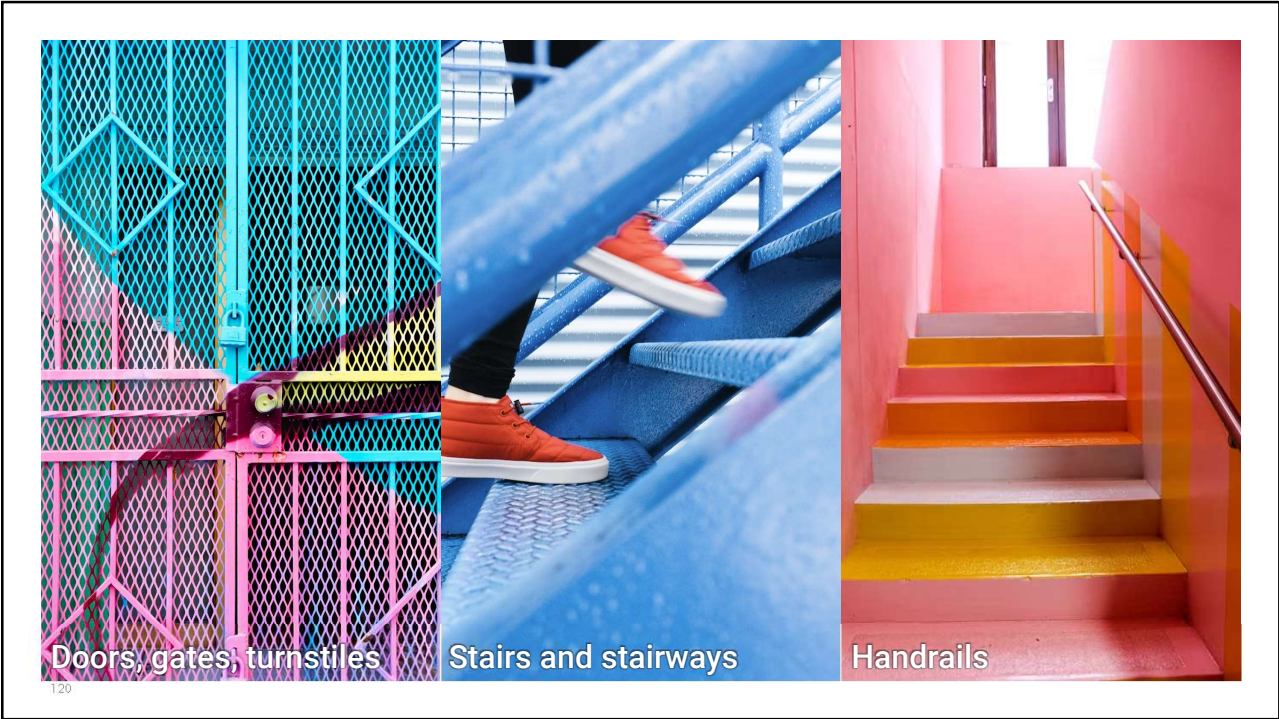

120



121



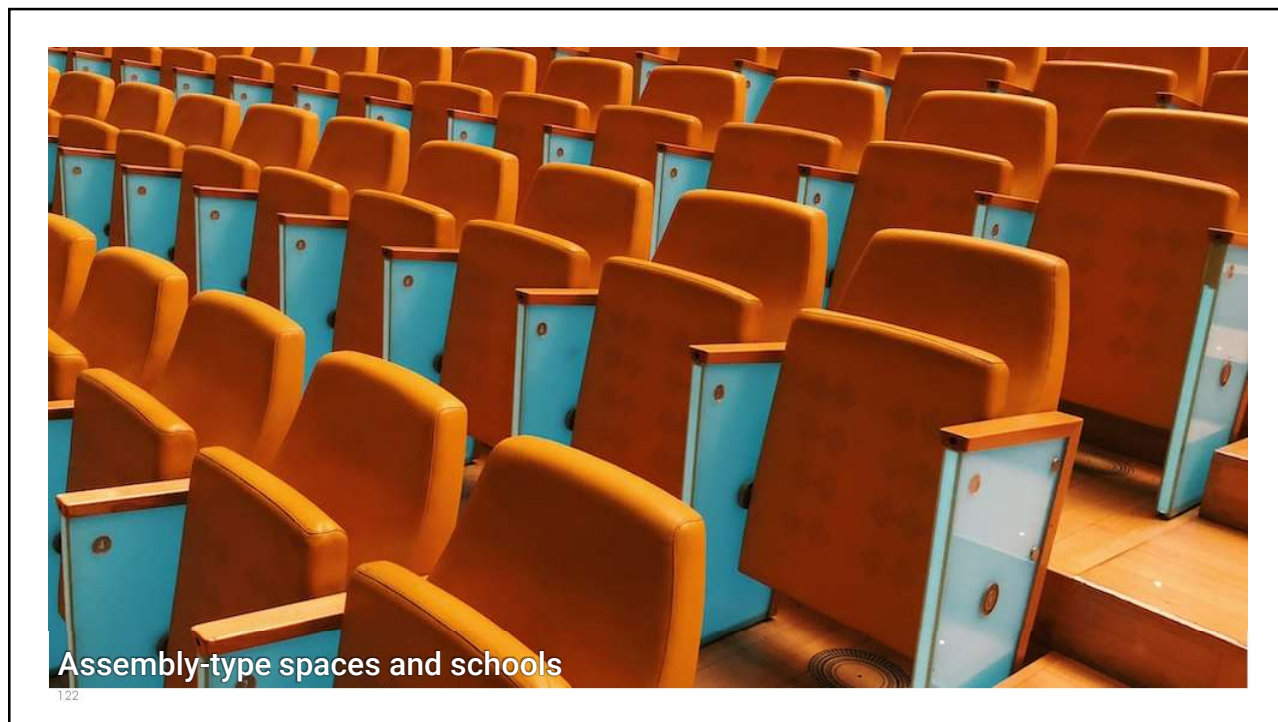

122